

# Johns-Manville Service to Industry

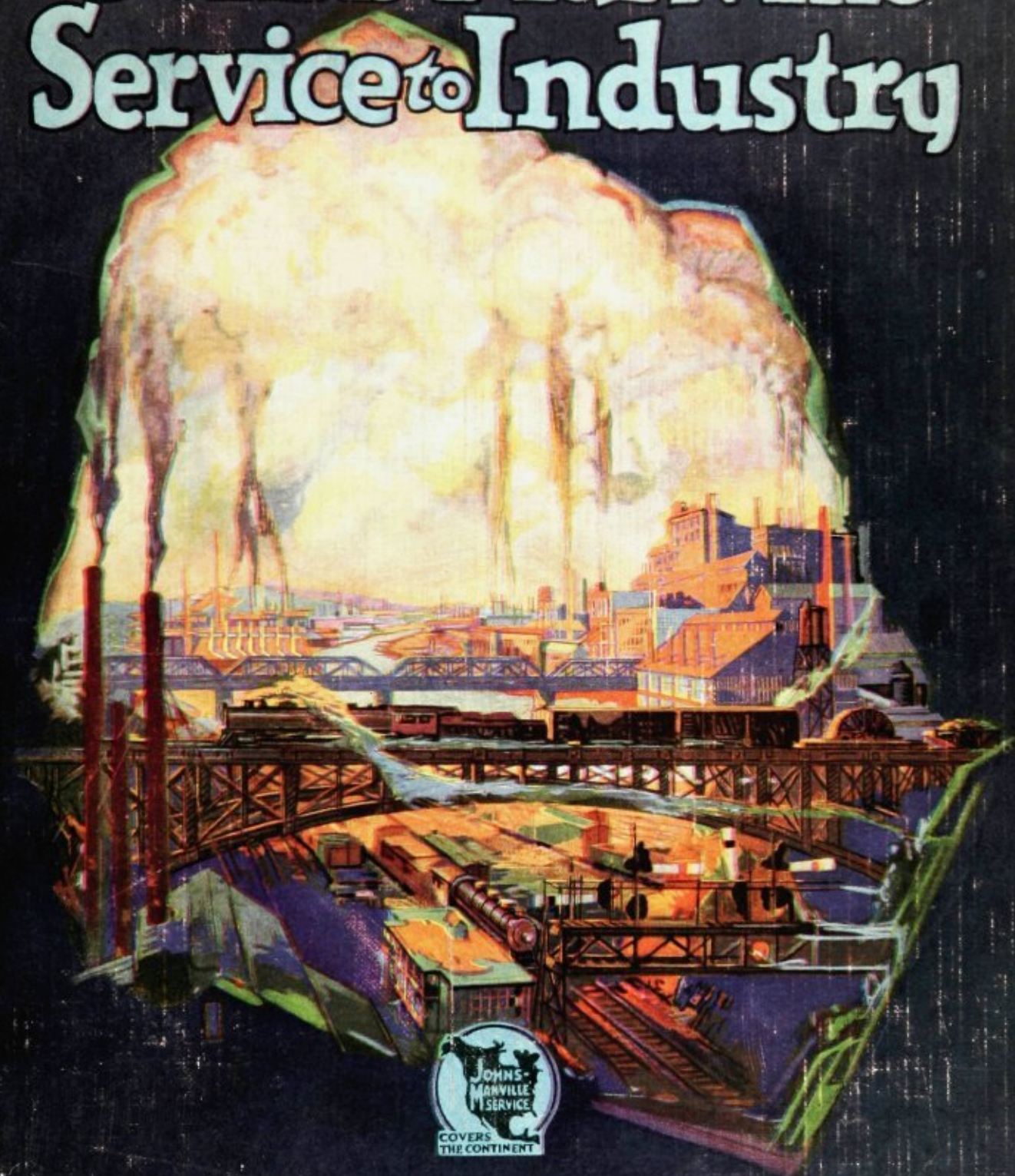

**JOHNS-MANVILLE  
INCORPORATED**











# Johns-Manville

## Service to Industry



*Asbestos Roofings, Heat Insulations, Packings;  
Electrical Insulations, Waterproofing,  
Industrial Flooring, etc.*

### Johns-Manville

Incorporated

Executive Offices: New York

Akron  
Albany  
Atlanta  
Baltimore  
Birmingham  
Boston  
Buffalo  
Canton  
Chicago  
Cincinnati  
Cleveland

Columbus  
Dallas  
Dayton  
Denver  
Detroit  
Duluth  
Erie  
Grand Rapids  
Houston  
Indianapolis  
Kansas City

Los Angeles  
Louisville  
Memphis  
Milwaukee  
Minneapolis  
Nashville  
Newark  
New Orleans  
Omaha  
Philadelphia  
Pittsburgh  
Portland (Me.)

Portland (Ore.)  
Providence (R. I.)  
Rochester  
Salt Lake City  
San Diego  
San Francisco  
Seattle  
Springfield (Mass.)  
Syracuse  
St. Louis  
St. Paul

Tacoma  
Toledo  
Tulsa  
Washington  
Wilkes-Barre  
Worcester (Mass.)  
Youngstown  
Havana, Cuba  
Rio de Janeiro, Brazil  
Sao Paulo, Brazil

### Canadian Johns-Manville Co., Limited

Montreal

Ottawa

Toronto

Vancouver

Winnipeg

*Printed in U. S. A.*

13066

# Johns-Manville Asbestos Mines



MILLS - ASBESTOS, P.Q.



MINES - CHRYSOTILE, ARIZ.

Johns-Manville owns  
extensive mines in both  
the United States and  
Canada.

In Canada, the mining  
of Asbestos is by the  
open quarry method.



MINES - DANVILLE, P.Q.

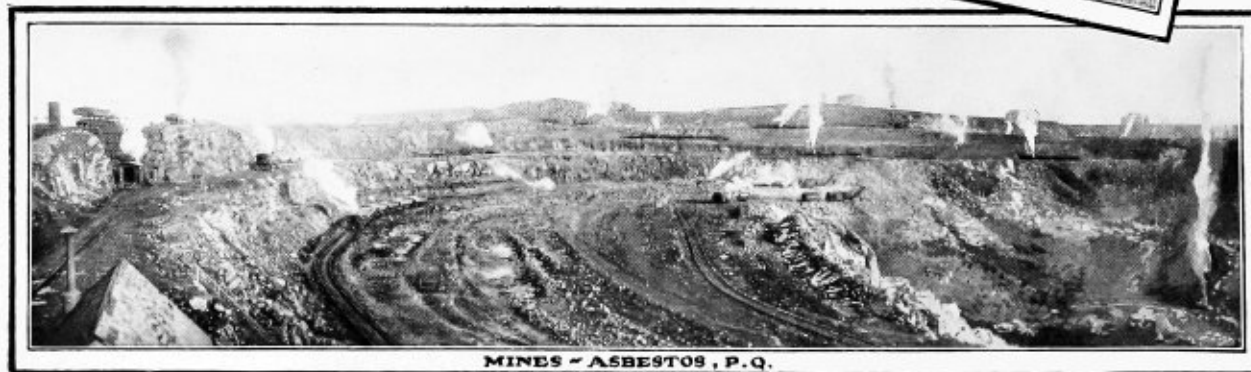

MINES - ASBESTOS, P.Q.



## Some of the Johns-Manville Factories

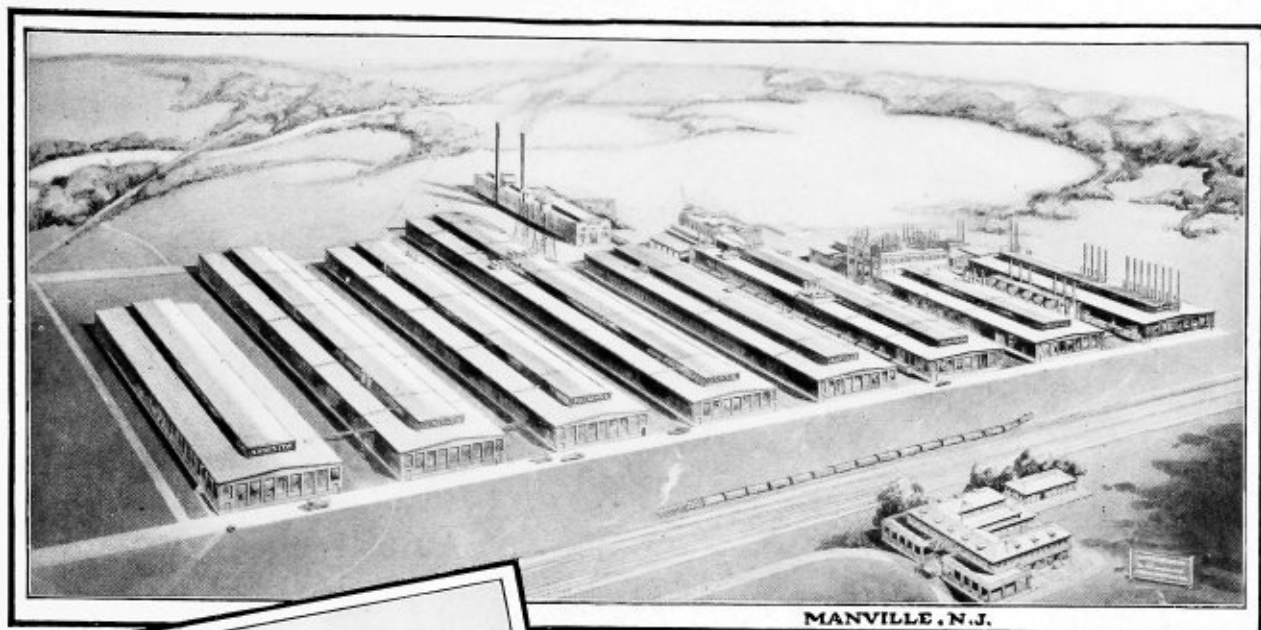

MANVILLE, N. J.



LOCKPORT, N. Y.



NEW ROCHELLE, N. Y.

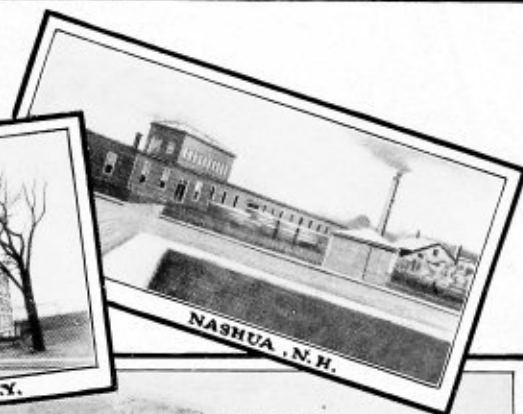

NASHUA, N. H.

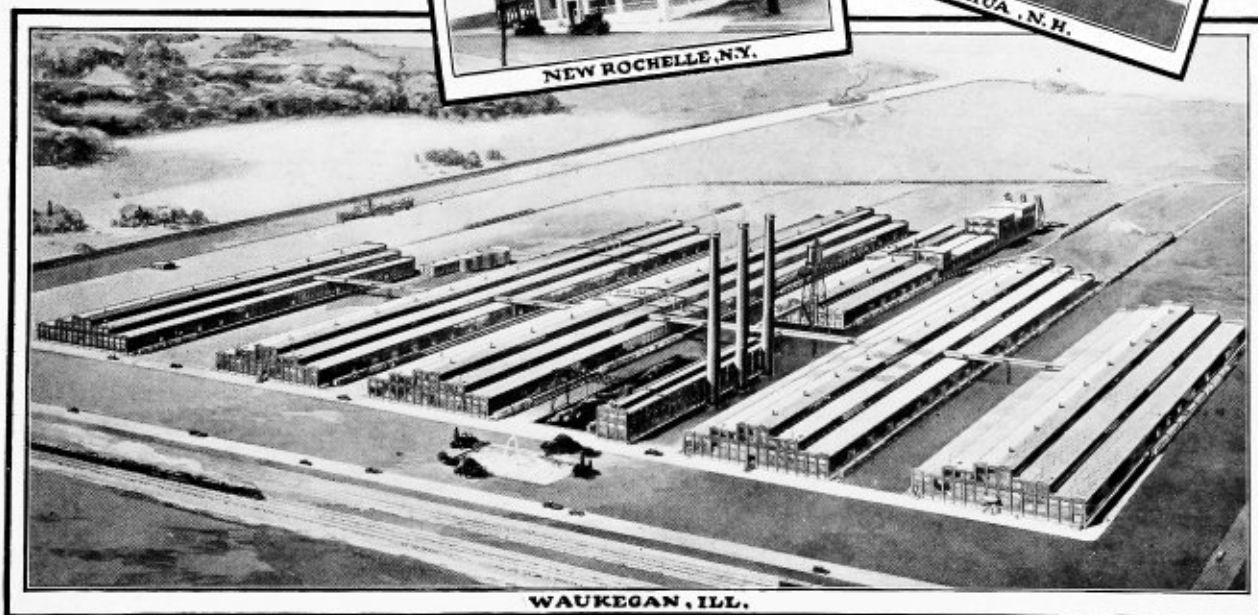

WAUKEGAN, ILL.

# A Few of the Main Johns-Manville Branches







# Johns-Manville Service to Industry

## *A Contribution to America's Progress*

**E**STABLISHED in 1858, Johns-Manville has achieved and maintained supremacy in its field because, through the scientific development of Asbestos, it has served the industrial world as has no other institution in America.

More than a century back, the power of steam was discovered. Coal then assumed new duties as steam fuel. Later the development of electrical power gave us another of Nature's forces to use, and in our use of steam, electricity and the intense fires required by industry, we were constantly faced with the problem of controlling the tremendous forces we had evoked. Asbestos has greatly assisted in the solution of this problem. Through insulations, packings, brake linings, roofings—in innumerable ways, it enables us to bend to man's service forces which were once his master.

Asbestos stands unique—a world-old rock which is immune to the action of heat, water, weather and wear—a fibrous mineral which can be spun, woven, felted or molded into useful form. So closely does it fit the needs of this new world of

steam, electricity and blazing furnaces, that it seems to have been almost purposely designed.

More than half a century has been devoted by Johns-Manville to making Asbestos fill these needs efficiently and economically; and this catalog is in reality a record of accomplishment. We are prepared to furnish a large variety of products made of Asbestos, Magnesia and related materials, as well as many other special articles for general industrial use.

Johns-Manville Service does not stop here. At each branch is maintained a fully organized Construction Department for the application of our materials. This department includes a force of experienced and competent engineers and skilled mechanics thoroughly familiar with the application of our products.

Throughout the book will be found valuable technical information relating to our various lines; and in the appendix is a collection of tables of engineering data which makes this volume not only a catalog but an engineer's handbook as well.



# A Few of the Main Johns-Manville Branches





# Johns-Manville Service to Industry

## *A Contribution to America's Progress*

**E**STABLISHED in 1858, Johns-Manville has achieved and maintained supremacy in its field because, through the scientific development of Asbestos, it has served the industrial world as has no other institution in America.

More than a century back, the power of steam was discovered. Coal then assumed new duties as steam fuel. Later the development of electrical power gave us another of Nature's forces to use, and in our use of steam, electricity and the intense fires required by industry, we were constantly faced with the problem of controlling the tremendous forces we had evoked. Asbestos has greatly assisted in the solution of this problem. Through insulations, packings, brake linings, roofings—in innumerable ways, it enables us to bend to man's service forces which were once his master.

Asbestos stands unique—a world-old rock which is immune to the action of heat, water, weather and wear—a fibrous mineral which can be spun, woven, felted or molded into useful form. So closely does it fit the needs of this new world of

steam, electricity and blazing furnaces, that it seems to have been almost purposely designed.

More than half a century has been devoted by Johns-Manville to making Asbestos fill these needs efficiently and economically; and this catalog is in reality a record of accomplishment. We are prepared to furnish a large variety of products made of Asbestos, Magnesia and related materials, as well as many other special articles for general industrial use.

Johns-Manville Service does not stop here. At each branch is maintained a fully organized Construction Department for the application of our materials. This department includes a force of experienced and competent engineers and skilled mechanics thoroughly familiar with the application of our products.

Throughout the book will be found valuable technical information relating to our various lines; and in the appendix is a collection of tables of engineering data which makes this volume not only a catalog but an engineer's handbook as well.

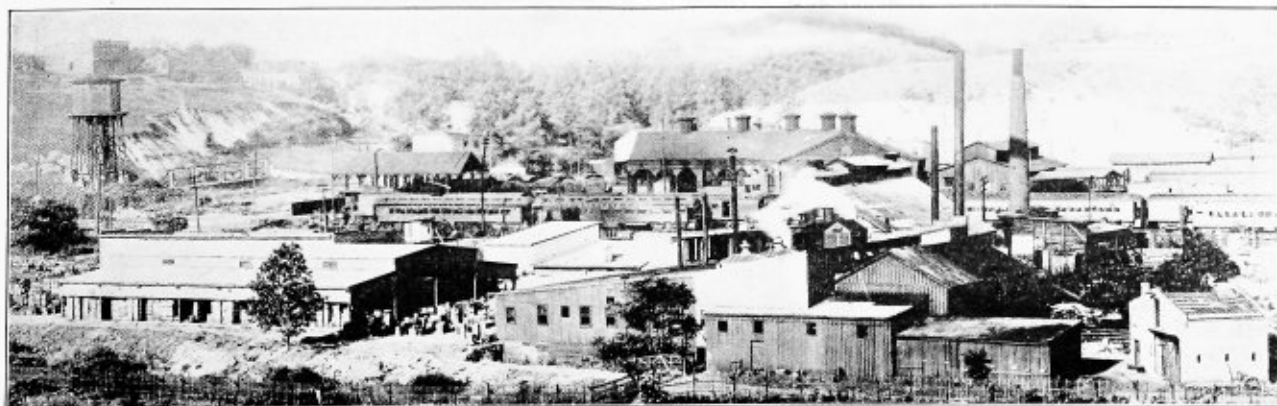





## The Story of Asbestos

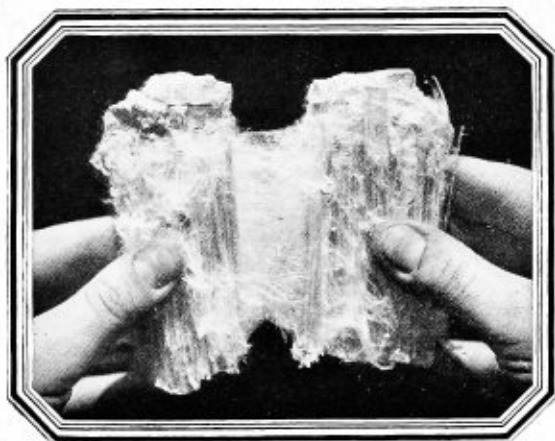

Piece of crude asbestos, just as it comes from the mine, split to show the mineral fibres.

**M**ILLIONS of years ago this earth went through untold ages of flame, slowly forming a marvelous mineral—as heavy and dense as marble, yet literally a nugget of silky fibre—**ASBESTOS**.

Asbestos is one of the most remarkable substances found in nature. Its unique properties are unparalleled. Wood burns—Asbestos will withstand flame and high temperatures. Stone disintegrates—Asbestos long resists erosion. Steel rusts—Asbestos is immune.

It is a peculiar species of the hornblende family of minerals. Its composition is chiefly silica, magnesia and a small quantity of alumina, ferrous oxide and water. The fibres formed by this chemical combination are perfectly smooth and non-tubular and in these respects are different from all other known fibres.

Paradoxically, it is the link which completes the chain between the vegetable and the mineral kingdoms. It is in fact a mineral which seems to possess some of the properties of the vegetable kingdom,

for it is at once fibrous and crystalline, elastic and brittle, heavy as rock in its crude state, yet as light as thistledown when treated mechanically. Through countless ages this mineralogical mystery has remained intact, having successfully resisted the manifold assaults of time.

Asbestos is found in various parts of the world, but of unusually pure quality in our extensive mines in the Province of Quebec, Canada and in Chrysotile, Arizona.

Asbestos is quarried in much the same manner as stone, and, when it comes from the mine, looks like ordinary rock except that it has a gray or dark green surface. After being mechanically treated the remarkable mineral fibres extracted from the rock can be spun, woven and otherwise manufactured into many useful articles.

For centuries Asbestos was but a curiosity—the mystic mineral, the paradox of ages. But today it is a recognized necessity, developed by the efforts, the courage and the resources of those manufacturers who, from the beginning, have recognized its possibilities.

# Johns-Manville Insulating Materials

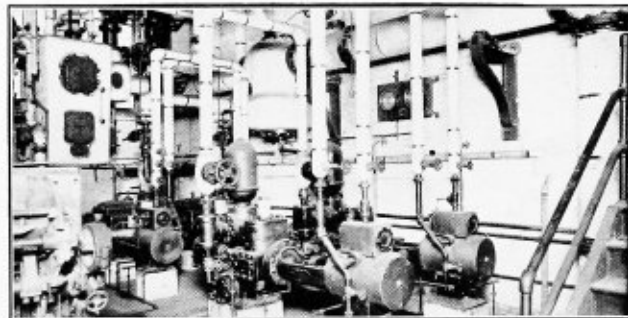





## Johns-Manville Insulating Materials

**M**ORE horsepower from the world's coal pile is one of the big problems of industry that touches us all. The economy with which coal is burned is as important in regulating the price of life's necessities as the cost of raw materials or the price of labor.

But if saving coal means losing power the ultimate economy is doubtful. Hence, "More power delivered per pound of coal" is the aim of all industry as it strives for economy. "More heat delivered per ton of coal" is the aim of every fuel-user.

It is the growth of production—with its correspondingly greater needs—that has made one of the most important results of the development of Asbestos by Johns-Manville, the saving of heat through insulation. Johns-Manville has developed materials, built on asbestos as a base, that retard the escape of heat from boilers, furnaces, pipes and flues—heat energy that would otherwise be wasted.

Johns-Manville Insulation Service, the

perfecting of these heat insulations and their application to thousands of power plants, is saving power by saving fuel—millions of dollars worth annually; nor does this include countless other installations on the heating systems of offices and buildings generally, where coal is burned for human comfort.

Thirty years' specialization, directed by the highest engineering talent, has enabled Johns-Manville to develop and produce insulations of exceptional efficiency and durability under every service condition.

Asbesto-Sponge Felted, for example—a remarkable felt which combines the "dead-air cell" insulation of sponge with the endurance of asbestos—is ranked first in efficiency by independent investigators. Or 85% Magnesia—or Improved Asbestocel, Zero, Anti-Sweat, or Brine and Ammonia Insulations—whatever your needs, you can meet them efficiently with one of the Johns-Manville Insulations described on the following pages.

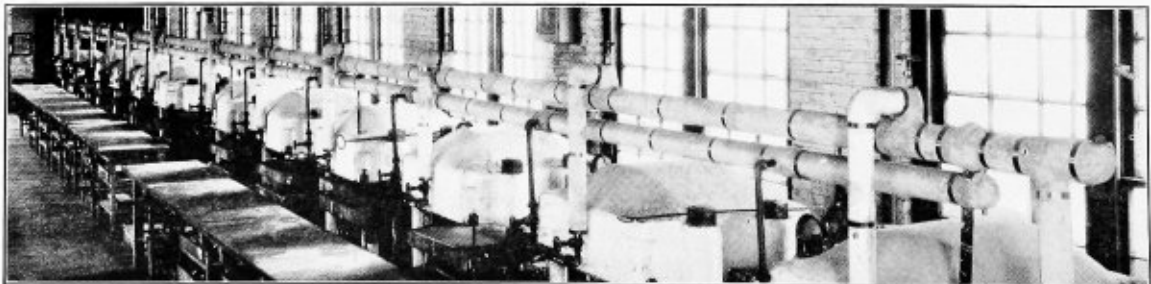



## Insulation

**T**HE real object of insulation is to prevent the flow of heat to the outside surrounding air from a boiler, apparatus or pipe in which it may be generated, stored or conveyed, or to prevent the flow of heat from the outside to fluids or solids which should be kept cool or at low temperatures.

The unit of heat is a B.t.u. (British thermal unit)—just as a gallon is a unit of liquid measure, a foot a unit of linear measure or an ampere a unit of electrical current flow.

The flow of heat from the fluid in a bare or insulated pipe to the outside surrounding air is measured by the number of heat units that flow through the walls of the pipe, or insulation, or both, and is usually expressed in the number of B.t.u. that flow through an area of one square foot in one hour—(B.t.u. per square foot per hour).

The rate of flow through a certain thickness and at a certain difference in temperature determines the conductivity of the material through which the heat flows. A smaller number of heat units flow through a given thickness of a material with a low conductivity than through one with a high conductivity.

The relative efficiencies of various insulating materials may be appreciated by comparing their conductivities under similar conditions.

An insulation that would allow no flow of heat through it would be 100 per cent. efficient.

Material that offered no resistance to the flow of heat would have an efficiency of 0 (zero).

The two examples above are the two extremes that do not exist, but the 100 per cent efficient insulation is nearly obtained by the application of any one of several Johns-Manville forms of insulation.

The efficiency of an insulating material is expressed by a percentage which is the per cent saving which would be effected by insulating a pipe with that material, over what would be lost if the pipe were left bare or uninsulated.

The efficiency per cent is obtained by subtracting the heat loss of the insulated pipe from the heat loss of the uninsulated or bare pipe and dividing the difference by the heat loss from the bare pipe. See How to Use Efficiency Tables on page 243 of Appendix.

On the following pages are tables and technical data pertaining to Johns-Manville Insulations, and on page 248 of Appendix is table showing thickness of steam pipe insulation recommended for various temperatures and pressures.



## Johns-Manville Asbesto-Sponge Felted Sectional Pipe Insulation

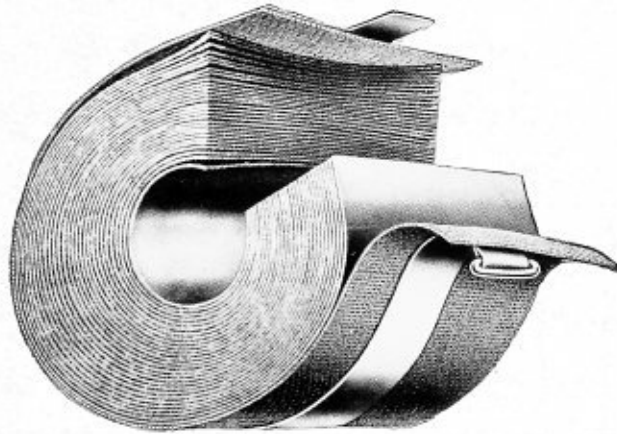

The most durable, efficient and adaptable insulation known for insulating pipes conveying steam at high pressures and temperatures.

**J**OHNS-MANVILLE Asbesto - Sponge Felted Insulation is made of layers of thin felt, composed of asbestos fibre and particles of finely ground spongy material forming an extremely cellular felt, built up like a book in laminated form, thereby confining a large volume of minute dead air cells in the felt and between the layers.

Johns-Manville Asbesto-Sponge Felted Insulation possesses not only very high initial efficiency as shown on the following pages, but permanent efficiency year after year because of its extremely durable construction.

Because of its construction, and unlike insulations of the molded type, Johns-Manville Asbesto-Sponge Felted is tough, flexible and practically indestructible. Pipe vibration, and the general wear and tear to which insulation is subjected, will not pulverize Sponge Felted Insulation or break it away from the pipe. Even if subjected to excessive moisture or saturated with water it will dry out and regain its initial efficiency. Whenever

necessary it can be removed from the pipes and replaced without injury.

Expansion and contraction of pipes will not wear away or harm the inside of Asbesto-Sponge Felted Insulation. Because of its durability, adaptability and permanent efficiency it provides exceptional economy. Sections are cut entirely through on one side only, which is a distinct advantage from an insulating standpoint.

Johns-Manville Asbesto-Sponge Felted Sectional Pipe Insulation is furnished in thicknesses from  $\frac{1}{2}$ " to 3", in 3-foot sections with canvas jacket and brass-lacquered bands, to fit standard pipe sizes. Specifications for insulating with Johns-Manville Asbesto-Sponge Felted Insulation will be found on page 11.

Also furnished in sheets and blocks for boilers, flues and other large regular surfaces. Sheets 24" x 36" and blocks 6" x 36", in thicknesses from  $\frac{1}{2}$ " to 4".

For descriptive data on this insulation in sheet and block form, see page 35.

See approximate weights and price list on page 28.



## Standard Specifications for Insulating Steam Pipes with Johns-Manville Asbesto-Sponge Felted Sectional Insulation

All live steam and feed water piping shall be insulated with Johns-Manville Asbesto-Sponge Felted

Sectional Insulation applied in different thicknesses for different classes of piping as follows:

Steam Pressure or Condition	Steam Temperature	Thickness of Insulation		
		Pipes larger than 4"	Pipes 2" to 4"	Pipes 1/2" to 1 1/4"
<b>SUPERHEATED STEAM PIPING</b>				
High Superheat .....	600° to 700° F.	3" *	3"	2"
Superheat .....	500° to 600° F.	2 1/2" *	2 1/2"	2"
* In addition to sectional insulation, Johns-Manville Insulating Cement 1/2" thick is to be applied over the Asbesto-Sponge Felted Insulation on pipes larger than 4"				
<b>HIGH PRESSURE (OR LOW SUPERHEAT) STEAM PIPING</b>				
Higher than 200 lbs. (or low superheat) .....	388° to 500° F.	2 1/2"	2"	1 1/2"
100 to 200 lbs. ....	338° to 388° F.	2"	1 1/2"	1"
<b>MEDIUM PRESSURE STEAM PIPING</b>				
25 to 100 lbs. ....	267° to 338° F.	1 1/2"	1 1/2"	1"
<b>LOW PRESSURE STEAM AND FEED WATER PIPING</b>				
0 to 25 lbs. ....	212° to 267° F.	1"	1"	1"
Feed Water Piping .....		1"	1"	1"

### Superheated Steam Piping

The insulation for superheated steam piping shall be applied in at least two layers to make up the total thickness required, as specified above. The first layer shall be applied to the piping without canvas jacket and be secured in place with annealed iron wire wrapped around its circumference and fastened on at intervals of 6". [All joints in the insulation shall be sealed during application with Johns-Manville Insulating Cement. These joints shall be filled with cement as the sections are applied and the sections shall then be tightly drawn together by means of the wires referred to above. Any cement protruding from the joints shall be plastered back with a trowel.]

The second or succeeding layers shall be applied as described above and shall be so placed

that all joints in adjacent layers are broken or staggered. Canvas jacket is to be omitted, except on outer layer of insulation on pipes 4" and smaller.

On all pipes larger than 4" after the sectional insulation has been applied as specified above there shall be applied over this a finish of Johns-Manville Insulating Cement 1/2" thick applied in two coats and troweled to a smooth and uniform surface.

Where the cement finish is not used it is more than ever essential that all joints be well sealed as the purpose of this cement finish is to make certain that there are no open joints through which heat can be lost.

### High Pressure Saturated Steam Piping (or Low Superheat)

The insulation for high pressure steam piping, where thickness is 2" or more, shall be applied in two layers to make up the total thickness as given above and, where thickness is 1 1/2" or less, in a single layer of the required thickness. The can-

vas jacket shall be omitted from the first layer where insulation is applied in two layers. All joints shall be cemented and the insulation shall be secured in place with wire in the same manner as specified for superheated steam piping.





## Low Pressure Steam and Feed Water Lines

The low pressure steam and feed water piping shall be insulated with a single layer of the required thickness, as given hereinbefore.

This insulation shall be applied with joints closely drawn together and canvas jacket pasted down.

## Fittings and Flanges

The bodies of all flanged fittings and all screwed fittings, including valves of the larger sizes (4" and over) shall be insulated with block and cement insulation of the same material and thickness as is used on the pipe lines on which they occur. The block insulation shall be securely wired in place with annealed iron wire and all joints shall be filled with insulating cement. The insulation shall be finished with Johns-Manville Insulating Cement troweled to a smooth and uniform surface.

All fittings smaller than 4" in size shall be insulated with Johns-Manville Insulating Cement applied in layers, each about  $\frac{1}{2}$ " thick, to the same total thickness as the adjacent pipe insulation. Each layer of this cement is to be allowed to dry before the next layer is applied and each layer, except the last, is to be applied with a rough surface. The last layer is to be troweled to a smooth and uniform surface.

Flanges may be insulated with either a perman-

ent or removable and replaceable type of insulation.

The permanent type of insulation shall consist of a built-up block and cement insulation constructed of the same material and of the same thickness as the adjacent pipe insulation and applied as described above for fittings.

The removable and replaceable type of flange cover shall be of the same thickness as the adjacent pipe insulation and shall be constructed as follows:

Use suitable size and length of Johns-Manville Asbesto-Sponge Felted Sectional Insulation to completely encircle flange and overlap the adjoining pipe insulation at least 2" on each side of the flange. Secure this flange insulation with wire and fill the space between the pipe and flange insulation with Johns-Manville Insulating Cement and apply a thin coat of Johns-Manville Insulating Cement over the entire surface of the flange cover.

## Finish of Insulation

After all insulation has been completely applied and all cement surfaces troweled to a smooth and uniform finish, apply over all insulation on piping and fittings an additional jacket of 8 oz. canvas. This jacket is to be sewed on over a lining of heavy rosin-sized paper and all seams

are to be located where least visible.

This canvas jacket shall be painted with first a coat of sizing and then with two coats of fire-proof paint or lead and oil paint of color desired.

(Where re-canvassing is not desired or is considered unnecessary, see Note B.)

## Weatherproof Jacket

If piping is located out of doors and is exposed to the weather the additional protection of 8 oz. canvas and paint may be omitted and in its place the insulation shall be protected with a Johns-Manville Asbestos Weatherproof Pipe Insulation Jacket, secured with rings formed of No. 16 Copper Wire wound once around the jacket and

ends twisted tightly together. These wire rings are to be placed on 4" centers. The jacket is to lap at least 3" in all directions and all horizontal laps are to be located on the side of the insulation and turned downward in order to shed all water from the surface.

**NOTE "A":** Johns-Manville maintains an Engineering Department at each of its Branches, which will on request recommend proper thicknesses of insulation for various special conditions.

**NOTE "B":** The light canvas jacket regularly furnished with the insulation shall be neatly pasted down over all laps. The pipe insulation shall be additionally secured in place with brass lacquered bands furnished with the material.

placed at suitable intervals at least two bands per section of pipe insulation.

All cement surfaces shall be finally finished with a jacket of light canvas neatly and securely pasted on.

**NOTE "C":** When extremely low temperatures are encountered out of doors special recommendations will be given by any Johns-Manville Branch Engineering Department.





## What Insulation Efficiency Means

**T**HE efficiency of an insulating material is expressed by a percentage, which is the per cent of heat saved by using the insulation as compared to what would be lost if no insulation were used and the pipe left bare or uninsulated.

The efficiencies of all insulations vary according to the size of pipe to which they are applied and according to the differ-

ence in temperature between steam in the pipe and air surrounding the pipe, as well as according to thickness of insulation.

Complete information regarding the use of efficiency tables with examples to illustrate will be found on page 243.

For table showing total heat loss from bare pipes, see page 244.

**EFFICIENCIES OF STANDARD THICK JOHNS-MANVILLE ASBESTO-SPONGE FELTED SECTIONAL PIPE INSULATION ON VARIOUS SIZES OF PIPE**

Pipe Size, Inches	Temperature Difference Between Pipe Surface and Air Surrounding Pipe									
	50°	100°	150°	200°	250°	300°	350°	400°	450°	500°
	Per Cent. Efficiencies									
1/2	68.5%	71.2%	73.3%	75.5%	77.1%	78.7%	80.4%	81.9%	83.1%	84.5%
3/4	71.9	74.3	76.2	78.1	79.6	81.0	82.6	83.8	85.0	86.2
1	74.3	76.5	78.2	79.9	81.3	82.6	84.0	85.2	86.2	87.4
1 1/4	75.7	77.7	79.5	81.0	82.3	83.5	84.9	86.0	86.9	88.0
1 1/2	77.0	79.0	80.5	82.0	83.2	84.4	85.7	86.7	87.6	88.6
2	78.6	80.4	81.9	83.3	84.4	85.5	86.7	87.6	88.5	89.3
2 1/2	79.8	81.5	82.9	84.3	85.3	86.3	87.5	88.4	89.2	90.0
3	80.6	82.2	83.6	84.9	85.9	86.8	87.9	88.8	89.6	90.3
3 1/2	81.2	82.8	84.1	85.4	86.3	87.3	88.3	89.2	89.9	90.6
4	81.8	83.3	84.5	85.8	86.7	87.6	88.7	89.5	90.2	90.9
4 1/2	82.1	83.6	84.8	86.0	87.0	87.9	88.9	89.7	90.4	91.1
5	82.3	83.8	85.0	86.2	87.1	88.0	89.0	89.8	90.5	91.2
6	82.7	84.2	85.4	86.5	87.4	88.3	89.3	90.1	90.7	91.4
7	83.0	84.5	85.6	86.8	87.6	88.5	89.5	90.2	90.9	91.6
8	83.4	84.8	85.9	87.0	87.9	88.7	89.7	90.4	91.1	91.7
9	83.5	84.9	86.0	87.2	88.0	88.8	89.8	90.5	91.2	91.8
10	83.8	85.1	86.2	87.3	88.2	89.0	89.9	90.6	91.3	91.9

**EFFICIENCIES OF 1/2" THICK JOHNS-MANVILLE ASBESTO-SPONGE FELTED SECTIONAL PIPE INSULATION ON VARIOUS SIZES OF PIPE**

Pipe Size, Inches	Temperature Difference Between Pipe Surface and Air Surrounding Pipe									
	50°	100°	150°	200°	250°	300°	350°	400°	450°	500°
	Per Cent. Efficiencies									
1/2	70.3%	72.9%	75.0%	76.8%	78.4%	80.0%	81.5%	82.9%	84.2%	85.2%
3/4	73.7	75.9	77.7	79.4	80.9	82.4	83.5	84.9	86.0	87.0
1	76.1	78.1	79.8	81.3	82.7	84.1	85.1	86.3	87.3	88.1
1 1/4	77.8	79.7	81.2	82.5	83.8	85.1	86.1	87.2	88.2	89.0
1 1/2	79.0	80.7	82.3	83.5	84.7	85.0	86.9	88.0	88.8	89.9
2	81.0	82.7	84.0	85.2	86.2	87.2	88.1	89.1	89.9	90.6
2 1/2	82.1	83.7	85.1	86.1	87.0	88.1	88.8	89.8	90.5	91.1
3	83.0	84.5	85.7	86.8	87.7	88.7	89.4	90.3	91.0	91.6
3 1/2	83.6	85.0	86.2	87.2	88.1	89.1	89.8	90.6	91.3	91.9
4	84.2	85.5	86.7	87.7	88.5	89.5	90.1	91.0	91.6	92.1
4 1/2	84.6	85.9	87.1	88.0	88.8	89.8	90.4	91.2	91.8	92.3
5	85.0	86.3	87.4	88.3	89.1	90.0	90.6	91.4	92.0	92.5
6	85.4	86.7	87.8	88.6	89.4	90.3	90.9	91.7	92.2	92.7
7	85.9	87.1	88.0	89.0	89.8	90.6	91.2	91.9	92.5	92.9
8	86.2	87.5	88.4	89.1	90.0	90.8	91.4	92.1	92.7	93.1
9	86.4	87.7	88.6	89.3	90.1	90.9	91.5	92.2	92.8	93.2
10	86.6	87.8	88.8	89.6	90.3	91.0	91.6	92.3	92.9	93.4



# Johns-Manville Service to Industry



## EFFICIENCIES OF 2" THICK JOHNS-MANVILLE ASBESTO-SPONGE FELTED SECTIONAL PIPE INSULATION ON VARIOUS SIZES OF PIPE

Pipe Size, Inches	Temperature Difference Between Pipe Surface and Air Surrounding Pipe									
	50°	100°	150°	200°	250°	300°	350°	400°	450°	500°
	Per Cent. Efficiencies									
1/2	73.2%	75.6%	77.5%	79.2%	80.7%	82.0%	83.5%	84.6%	86.1%	87.4%
3/4	76.5	78.6	80.3	81.8	83.1	84.2	85.5	86.5	87.8	88.8
1	78.8	80.7	82.2	83.6	84.8	85.8	87.0	87.8	89.0	90.0
1 1/4	80.5	82.0	83.6	84.9	86.0	87.1	88.0	88.8	89.8	90.8
1 1/2	81.7	83.4	84.7	85.9	86.9	87.8	88.7	89.5	90.4	91.2
2	83.6	85.1	86.2	87.2	88.1	89.0	89.9	90.6	91.4	92.1
2 1/2	84.3	86.1	87.2	88.2	89.0	89.7	90.5	91.2	92.0	92.7
3	85.6	86.8	87.9	88.8	89.6	90.3	91.1	91.7	92.5	93.2
3 1/2	86.2	87.4	88.4	89.3	90.1	90.8	91.5	92.1	92.8	93.5
4	86.7	87.9	88.8	89.7	90.5	91.1	91.8	92.4	93.1	93.7
4 1/2	87.1	88.3	89.2	90.0	90.7	91.3	92.1	92.6	93.3	93.9
5	87.5	88.6	89.5	90.3	91.0	91.6	92.3	92.8	93.5	94.1
6	88.0	89.1	89.9	90.7	91.3	91.9	92.6	93.1	93.8	94.3
7	88.4	89.4	90.2	91.0	91.6	92.2	92.8	93.3	94.0	94.5
8	88.6	89.6	90.4	91.2	91.8	92.4	93.0	93.4	94.1	94.6
9	88.9	89.9	90.6	91.4	92.0	92.5	93.1	93.6	94.2	94.7
10	89.1	90.1	90.8	91.5	92.2	92.7	93.3	93.7	94.3	94.8

## EFFICIENCIES OF 2 1/2" THICK JOHNS-MANVILLE ASBESTO-SPONGE FELTED SECTIONAL PIPE INSULATION ON VARIOUS SIZES OF PIPE

Pipe Size, Inches	Temperature Difference Between Pipe Surface and Air Surrounding Pipe									
	50°	100°	150°	200°	250°	300°	350°	400°	450°	500°
	Per Cent. Efficiencies									
1/2	75.0%	77.3%	78.9%	80.7%	82.1%	83.7%	84.8%	85.9%	87.0%	88.0%
3/4	78.2	80.0	81.6	83.2	84.4	85.7%	86.7	87.7	88.5	89.3
1	80.5	82.2	83.5	85.0	86.0	87.2	88.1	89.0	89.7	90.4
1 1/4	82.2	83.8	84.9	86.2	87.2	88.3	89.1	90.0	90.6	91.3
1 1/2	83.4	84.9	86.0	87.2	88.1	89.1	89.9	90.6	91.2	91.9
2	85.2	86.5	87.5	88.6	89.4	90.3	91.0	91.7	92.2	92.8
2 1/2	86.3	87.5	88.4	89.4	90.2	91.0	91.7	92.3	92.8	93.3
3	87.1	88.3	89.1	90.1	90.8	91.6	92.2	92.7	93.2	93.7
3 1/2	87.8	88.9	89.7	90.6	91.2	92.0	92.6	93.1	93.5	94.0
4	88.3	89.3	90.1	90.9	91.6	92.3	92.9	93.4	93.8	94.3
4 1/2	88.7	89.7	90.4	91.2	91.9	92.6	93.1	93.6	94.0	94.5
5	89.0	90.0	90.7	91.5	92.0	92.8	93.3	93.8	94.2	94.6
6	89.5	90.4	91.1	91.9	92.0	93.1	93.6	94.1	94.5	94.8
7	89.9	90.8	91.4	92.2	92.7	93.4	93.8	94.3	94.7	95.0
8	90.1	91.0	91.6	92.4	92.9	93.5	94.0	94.4	94.8	95.1
9	90.3	91.2	91.8	92.5	93.1	93.7	94.1	94.6	94.9	95.2
10	90.5	91.4	92.0	92.7	93.2	93.8	94.2	94.7	95.0	95.3

## EFFICIENCIES OF 3" THICK JOHNS-MANVILLE ASBESTO-SPONGE FELTED SECTIONAL PIPE INSULATION ON VARIOUS SIZES OF PIPE

Pipe Size, Inches	Temperature Difference Between Pipe Surface and Air Surrounding Pipe									
	50°	100°	150°	200°	250°	300°	350°	400°	450°	500°
	Per Cent. Efficiencies									
1/2	76.8%	78.9%	80.6%	82.1%	83.4%	84.6%	85.8%	87.0%	88.1%	89.1%
3/4	79.7	81.7	83.1	84.5	85.6	86.6	87.6	88.6	89.6	90.5
1	81.9	83.5	84.8	86.1	87.1	88.0	88.9	89.8	90.7	91.5
1 1/4	83.5	85.0	86.2	87.3	88.2	89.1	89.9	90.8	91.6	92.3
1 1/2	84.7	86.1	87.2	88.3	89.1	89.9	90.6	91.4	92.2	92.8
2	86.5	87.7	88.7	89.6	90.3	91.0	91.7	92.4	93.1	93.7
2 1/2	87.5	88.7	89.6	90.5	91.1	91.7	92.4	93.0	93.5	94.2
3	88.4	89.5	90.3	91.2	91.7	92.3	92.9	93.5	94.1	94.6
3 1/2	89.0	90.0	90.8	91.6	92.1	92.7	93.3	93.8	94.4	94.8
4	89.5	90.5	91.2	92.0	92.5	93.0	93.6	94.1	94.6	95.1
4 1/2	89.9	90.8	91.5	92.2	92.8	93.3	93.8	94.3	94.8	95.2
5	90.2	91.1	91.8	92.5	93.0	93.5	94.0	94.5	95.0	95.4
6	90.7	91.5	92.2	92.9	93.3	93.8	94.3	94.8	95.2	95.6
7	91.1	91.9	92.5	93.2	93.6	94.1	94.5	95.0	95.4	95.8
8	91.3	92.1	92.7	93.4	93.8	94.2	94.7	95.1	95.5	95.9
9	91.5	92.3	92.9	93.5	93.9	94.4	94.8	95.2	95.6	96.0
10	91.7	92.5	93.0	93.6	94.0	94.5	94.9	95.3	95.7	96.1



## Johns-Manville 85% Magnesia Sectional Pipe Insulation



For the insulation of pipes conveying steam

**J**OHNS-MANVILLE 85% Magnesia Pipe Insulation combines the high non-conducting qualities of carbonate of magnesia and asbestos, affording a light, efficient insulation. Under actual service conditions, Johns-Manville 85% Magnesia has proven itself to be the most durable and efficient insulation of the moulded type. The Johns-Manville manufacturing process produces an 85% Magnesia with the maximum number of voids or minute dead-air cells which increase its natural resistance to heat transmission and reduce its weight. In addition, this process provides maximum mechanical strength consistent with high efficiency.

The efficiencies of Johns-Manville 85% Magnesia are given on pages 17 and 18.

Johns-Manville 85% Magnesia Sectional Pipe Insulation is made in various thick-

nesses from standard (approximately 1" thick) to 3" thick, in 3-foot sections with canvas jacket and brass-lacquered bands, to fit standard pipe sizes up to and including 12" in diameter. For larger pipes, curved segments or blocks are supplied.

Also furnished in blocks for covering boilers, boiler flues and other large regular and irregular surfaces.

Blocks are made 3" x 18" or 6" x 36", in thicknesses from 1/2" to 4".

Specifications for the application of Johns-Manville 85% Magnesia Insulation will be found on the following page.

For descriptive data on this insulation in sheet and block form, see page 36.

See approximate weights and price list on page 28.



## Standard Specifications for Insulating Steam Pipes with Johns-Manville 85% Magnesia Sectional Insulation

All steam piping shall be insulated with Johns-Manville 85% Magnesia Sectional Insulation of proper size and thickness, with all joints sealed with Johns-Manville Insulating Cement. (See note "A".)

The bodies of all flanged fittings and all screwed fittings, including valves of the larger sizes (4" and over) shall be insulated with block and cement insulation of the same material and thickness as is used on the pipe lines on which they occur. The block insulation shall be securely wired in place with annealed iron wire and all joints shall be filled with insulating cement. The insulation shall be finished with Johns-Manville Insulating Cement troweled to a smooth and uniform surface.

All fittings smaller than 4" in size shall be insulated with Johns-Manville Insulating Cement applied in layers, each about  $\frac{1}{2}$ " thick, to the same total thickness as the adjacent pipe insulation. Each layer of this cement is to be allowed to dry before the next layer is applied and each layer, except the last, is to be applied with a rough surface. The last layer is to be troweled to a smooth and uniform surface.

All flanges shall be insulated by method "A" or

"B," depending upon whether flange insulation is to be removable and replaceable or non-replaceable.

Method "A"—Use No. 19 half-inch mesh galvanized iron wire netting for forming frame for the removable and replaceable flange.

This wire mesh should be cut into two pieces of such a size that each piece will encircle one-half ( $\frac{1}{2}$ ) the flange, and with the ends turned down so that they will meet and come in contact with the insulation on the pipe.

Attach to this wire mesh frame Johns-Manville 85% Magnesia blocks or sectional insulation of proper size and length and wire in place with wire lacing.

Apply on the ends of this removable frame Johns-Manville Insulating Cement of the same thickness as that of blocks or sectional insulation, then apply, over entire surface of flange cover, one-half inch finish of Johns-Manville Insulating Cement.

Method "B"—Apply built-up block and cement insulation of the same material and of the same thickness as the adjacent pipe insulation, as described above for fittings.

### Finish of Insulation

All of the above insulation, including fittings, valves and flanges, shall be finally finished and additionally protected with 8-ounce canvas, neatly sewed on, over rosin-sized paper, and this canvas painted either with fireproof paint, or lead

and oil paint, of the color desired. This extra canvas covering to be placed over the canvas jacket furnished with this insulation. (When re-canvassing is not desired or considered unnecessary, see note "B".)

### Weatherproof Jacket

If piping is located out-of-doors and exposed to the weather, the additional protection of 8-ounce canvas and paint may be omitted and in its place the insulation shall be protected with a Johns-Manville Asbestos Weather-proof Pipe Insulation Jacket secured with rings formed of No. 16 copper wire wound once around the jacket

and ends twisted tightly together. These wire rings are to be placed on four-inch (4") centers. The jacket is to lap at least three inches (3") in all directions, and all horizontal laps are to be located on the side of the insulation and turned downward in order to shed all water from the surface. (See note "C".)

NOTE "A"—Johns-Manville maintains an engineering department at each of its branches, which will, on request, recommend proper thickness for various pressures and temperatures.

NOTE "B"—If insulation is not to be re-canvassed, lacquered bands furnished with the insula-

tion are to be applied, at 18" intervals, on all sectional insulation.

NOTE "C"—When extremely low temperatures are encountered out-of-doors, special recommendations will be given by any Johns-Manville Branch Engineering Department.





## What Insulation Efficiency Means

**T**HE efficiency of an insulating material is expressed by a percentage, which is the per cent of heat saved by using the insulation as compared to what would be lost if no insulation were used and the pipe left bare or uninsulated.

The efficiencies of all insulations vary according to the size of pipe to which they are applied and according to the difference

in temperature between steam in the pipe and air surrounding the pipe, as well as according to thickness of insulation.

Complete information regarding the use of efficiency tables with examples to illustrate will be found on page 243.

For table showing total heat loss from bare pipes, see page 244.

**EFFICIENCIES OF STANDARD THICK JOHNS-MANVILLE 85% MAGNESIA SECTIONAL PIPE INSULATION ON VARIOUS SIZES OF PIPES**

Pipe Size, Inches	Temperature Difference Between Pipe Surface and Air Surrounding Pipe									
	50°	100°	150°	200°	250°	300°	350°	400°	450°	500°
	Per Cent. Efficiencies									
1/2	58.1%	61.7%	64.8%	67.9%	70.5%	72.7%	74.9%	76.8%	78.7%	80.6%
3/4	62.6	65.8	68.6	71.3	73.7	75.7	77.7	79.3	81.1	82.7
1	65.8	68.7	71.2	73.7	75.9	77.7	79.5	81.1	82.6	84.0
1 1/4	67.7	70.3	72.9	75.1	77.2	78.9	80.6	82.1	83.5	85.0
1 1/2	69.6	72.1	74.3	76.4	78.3	80.0	81.7	83.0	84.4	85.7
2	74.3	76.7	78.6	80.5	82.1	83.3	84.5	85.7	87.0	88.2
2 1/2	75.8	78.0	79.8	81.6	82.9	84.2	85.5	86.7	87.9	88.9
3	76.7	78.8	80.6	82.3	83.6	84.8	86.0	87.1	88.2	89.3
3 1/2	77.4	79.5	81.2	82.9	84.2	85.4	86.5	87.6	88.7	89.7
4	80.4	81.7	83.1	84.5	85.8	86.9	88.1	89.1	90.0	90.8
4 1/2	83.7	82.0	83.5	84.8	86.0	87.1	88.3	89.3	90.1	91.0
5	81.0	82.3	83.7	85.0	86.2	87.3	88.4	89.4	90.3	91.2
6	81.4	82.7	84.1	85.4	86.4	87.6	88.7	89.7	90.5	91.3
7	82.0	83.4	84.7	86.0	87.1	88.2	89.2	90.1	91.0	91.8
8	82.3	83.7	85.1	86.2	87.3	88.4	89.4	90.2	91.1	91.9
9	82.5	84.0	85.2	86.4	87.5	88.5	89.5	90.3	91.2	92.0
10	82.8	84.2	85.4	86.5	87.6	88.7	89.6	90.4	91.3	92.1

**EFFICIENCIES OF 1 1/2" THICK JOHNS-MANVILLE 85% MAGNESIA SECTIONAL PIPE INSULATION ON VARIOUS SIZES OF PIPES**

Pipe Size, Inches	Temperature Difference Between Pipe Surface and Air Surrounding Pipe									
	50°	100°	150°	200°	250°	300°	350°	400°	450°	500°
	Per Cent. Efficiencies									
1/2	63.4%	69.4%	71.8%	74.2%	76.2%	78.1%	80.0%	81.7%	83.5%	85.2%
3/4	76.2	72.8	74.9	77.1	79.0	80.6	82.2	83.8	85.4	87.0
1	73.0	75.3	77.3	79.2	81.0	82.5	84.0	85.3	86.7	88.1
1 1/4	74.9	77.1	78.9	80.6	82.2	83.8	85.0	86.3	87.6	89.0
1 1/2	76.3	78.2	80.0	81.7	83.2	84.6	85.9	87.2	88.5	89.9
2	78.5	80.5	82.0	83.6	84.8	85.9	87.1	88.3	89.5	90.6
2 1/2	79.8	81.6	83.2	84.6	85.7	86.9	88.0	89.1	90.1	91.1
3	80.8	82.5	83.9	85.3	86.5	87.6	88.7	89.6	90.6	91.6
3 1/2	81.5	83.0	84.4	85.8	86.9	88.0	89.0	90.0	91.0	91.9
4	82.1	83.6	85.0	86.3	87.3	88.3	89.3	90.3	91.3	92.1
4 1/2	82.6	84.1	85.4	86.7	87.7	88.7	89.7	90.6	91.5	92.3
5	83.0	84.5	85.8	87.0	88.0	89.0	90.0	90.8	91.7	92.5
6	83.5	85.0	86.2	87.3	88.3	89.3	90.2	91.1	91.9	92.7
7	84.1	85.4	86.6	87.6	88.8	89.7	90.5	91.3	92.1	92.9
8	84.4	85.8	86.9	87.9	88.9	89.9	90.8	91.5	92.4	93.1
9	84.6	86.0	87.1	88.1	89.1	90.0	90.9	91.7	92.5	93.2
10	84.9	86.2	87.3	88.3	89.2	90.1	91.0	91.8	92.6	93.4



# Johns-Manville Service to Industry



## EFFICIENCIES OF 2" THICK JOHNS-MANVILLE 85% MAGNESIA SECTIONAL PIPE INSULATION ON VARIOUS SIZES OF PIPE

Pipe Size, Inches	Temperature Difference Between Pipe Surface and Air Surrounding Pipe									
	50°	100°	150°	200°	250°	300°	350°	400°	450°	500°
	Per Cent. Efficiencies									
1/2	69.4%	72.9%	75.2%	77.1%	79.0%	80.7%	82.3%	84.0%	85.3%	86.8%
3/4	73.2	76.0	78.3	80.0	81.6	83.1	84.5	86.0	87.1	88.2
1	75.8	78.4	80.4	82.0	83.4	84.8	86.1	87.3	88.3	89.6
1 1/4	77.8	79.8	82.0	83.4	84.7	86.0	87.2	88.4	89.2	90.2
1 1/2	79.1	81.4	83.2	84.5	85.7	86.9	87.9	89.1	89.8	90.8
2	81.3	83.3	84.8	85.9	87.0	88.2	89.2	90.2	90.9	91.7
2 1/2	82.1	84.4	85.9	87.0	88.0	89.0	89.8	90.8	91.5	92.3
3	83.6	85.2	86.7	87.7	88.7	89.6	90.5	91.4	92.0	92.9
3 1/2	84.3	86.0	87.2	88.2	89.2	90.2	90.9	91.8	92.4	93.2
4	84.8	86.4	87.8	88.7	89.6	90.5	91.2	92.1	92.7	93.4
4 1/2	85.3	86.9	88.1	89.0	89.9	90.7	91.5	92.3	92.9	93.6
5	85.7	87.2	88.4	89.3	90.2	91.0	91.8	92.5	93.1	93.8
6	86.3	87.8	88.9	89.8	90.5	91.3	92.1	92.8	93.4	94.0
7	86.8	88.1	89.2	90.1	90.8	91.6	92.3	93.0	93.6	94.2
8	87.0	88.4	89.4	90.3	91.1	91.8	92.5	93.1	93.7	94.3
9	87.3	88.7	89.7	90.5	91.3	92.0	92.6	93.3	93.9	94.4
10	87.6	88.9	89.9	90.7	91.5	92.2	92.8	93.4	94.0	94.5

## EFFICIENCIES OF 2 1/2" THICK JOHNS-MANVILLE 85% MAGNESIA SECTIONAL PIPE INSULATION ON VARIOUS SIZES OF PIPE

Pipe Size, Inches	Temperature Difference Between Pipe Surface and Air Surrounding Pipe									
	50°	100°	150°	200°	250°	300°	350°	400°	450°	500°
	Per Cent. Efficiencies									
1/2	71.7%	74.6%	76.6%	78.4%	80.3%	82.1%	83.6%	84.9%	86.3%	87.7%
3/4	75.4	77.6	79.6	81.2	82.8	84.3	85.6	86.8	87.9	89.1
1	78.0	80.1	81.7	83.2	84.6	85.9	87.1	88.2	89.2	90.2
1 1/4	79.9	81.9	83.2	84.5	85.9	87.1	88.2	89.3	90.1	91.1
1 1/2	81.2	83.1	84.5	85.7	86.9	88.0	89.1	89.9	90.8	91.7
2	83.3	84.9	86.1	87.2	88.3	89.3	90.3	91.0	91.8	92.6
2 1/2	84.5	86.0	87.1	88.1	89.1	90.1	91.0	91.8	92.5	93.2
3	85.4	86.9	87.9	88.9	89.9	90.8	91.6	92.3	92.9	93.6
3 1/2	86.2	87.6	88.6	89.5	90.3	91.2	92.0	92.6	93.2	93.9
4	86.8	88.0	89.0	89.8	90.7	91.6	92.3	92.9	93.5	94.2
4 1/2	87.2	88.5	89.3	90.2	91.1	91.9	92.5	93.2	93.7	94.4
5	87.6	88.8	89.7	90.5	91.3	92.1	92.8	93.4	93.9	94.5
6	88.1	89.2	90.1	90.9	91.7	92.4	93.1	93.7	94.2	94.7
7	88.6	89.7	90.5	91.3	92.0	92.6	93.3	93.9	94.4	94.9
8	88.8	89.9	90.7	91.5	92.2	92.8	93.5	94.0	94.5	95.0
9	89.0	90.1	90.9	91.6	92.4	93.1	93.6	94.1	94.6	95.1
10	89.3	90.4	91.1	91.8	92.5	93.2	93.7	94.2	94.7	95.2

## EFFICIENCIES OF 3" THICK JOHNS-MANVILLE 85% MAGNESIA SECTIONAL PIPE INSULATION ON VARIOUS SIZES OF PIPE

Pipe Size, Inches	Temperature Difference Between Pipe Surface and Air Surrounding Pipe									
	50°	100°	150°	200°	250°	300°	350°	400°	450°	500°
	Per Cent. Efficiencies									
1/2	73.7%	76.3%	78.5%	80.2%	81.7%	83.4%	84.8%	86.1%	87.3%	88.4%
3/4	77.0	79.4	81.2	82.8	84.2	85.5	86.7	87.8	88.9	89.9
1	79.5	81.4	83.1	84.6	85.8	87.0	88.1	89.1	90.0	90.9
1 1/4	81.3	83.1	84.7	85.9	87.0	88.2	89.2	90.1	91.0	91.8
1 1/2	82.8	84.4	85.8	87.1	88.0	89.1	89.9	90.8	91.7	92.3
2	84.7	86.2	87.5	88.5	89.3	90.2	91.1	91.9	92.6	93.3
2 1/2	85.8	87.3	88.5	89.5	90.2	91.0	91.8	92.5	93.1	93.8
3	86.8	88.2	89.2	90.2	90.9	91.7	92.4	93.0	93.7	94.2
3 1/2	87.5	88.8	89.8	90.7	91.4	92.1	92.8	93.4	94.0	94.5
4	88.1	89.3	90.2	91.1	91.7	92.4	93.1	93.7	94.2	94.8
4 1/2	88.5	89.7	90.6	91.4	92.1	92.8	93.4	93.9	94.4	94.9
5	88.9	90.0	90.9	91.7	92.3	93.0	93.6	94.1	94.6	95.1
6	89.5	90.4	91.3	92.1	92.7	93.3	93.9	94.4	94.9	95.3
7	89.9	90.9	91.7	92.5	93.1	93.6	94.1	94.6	95.1	95.5
8	90.1	91.1	91.9	92.7	93.2	93.7	94.3	94.8	95.2	95.6
9	90.4	91.3	92.1	92.8	93.3	93.9	94.4	94.9	95.3	95.7
10	90.6	91.5	92.2	92.9	93.4	94.0	94.5	95.0	95.4	95.8



## Johns-Manville Improved Asbestocel Sectional Pipe Insulation

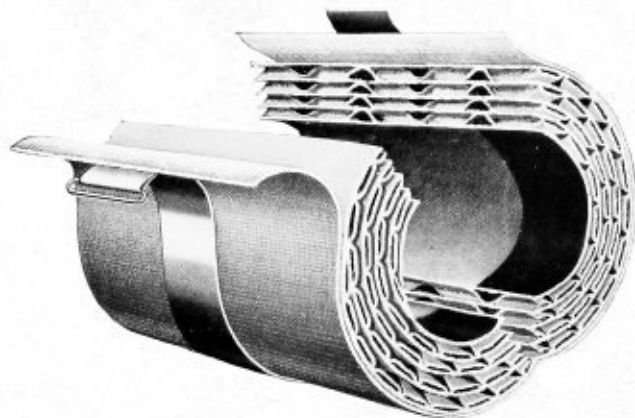

Every section of Johns-Manville Improved Asbestocel Sectional Insulation is marked with a red band on the inside of each end in the same position shown by the shaded area in the illustration. This mark distinguishes this more efficient, stronger Improved Asbestocel from ordinary coverings.

**F**OR insulating pipes conveying steam at medium or low pressures or for pipes conveying hot water.

Johns-Manville Improved Asbestocel is a cellular type of insulation made up of alternate layers of plain and corrugated asbestos felt, which form a multitude of air cells closed upon themselves, so that each chamber contains dead air that cannot circulate. These dead air cells are formed by the corrugations, which run in two directions, longitudinally and circumferentially.

Because of its cellular structure, longitudinal circulation of air is prevented.

Improved Asbestocel is strong and durable because the cells form numerous arches which give the insulation strength, and this construction accounts for its ability to withstand vibration and wear and tear.

Johns-Manville Improved Asbestocel Sectional Pipe Insulation is furnished in 2, 3, 4, 5 and 6 ply thicknesses, each ply approximately  $\frac{1}{4}$ " thick. It is made in 3-foot sections with canvas jacket and brass-lacquered bands, to fit standard sizes of pipe.

Specifications for Johns-Manville Improved Asbestocel Insulation will be found on page 21.

Also furnished in sheet and block form for boilers, flues and other large regular surfaces. Sheets, 36" x 36" and blocks 6" x 36", 4" x 18", and 3" x 18", or special sizes, in thicknesses from  $\frac{1}{2}$ " to 4".

For descriptive data on this insulation in sheet and block form, see page 40.

See approximate weights and price list on page 28.



## Johns-Manville Fine Corrugated Improved Asbestocel Sectional Pipe Insulation

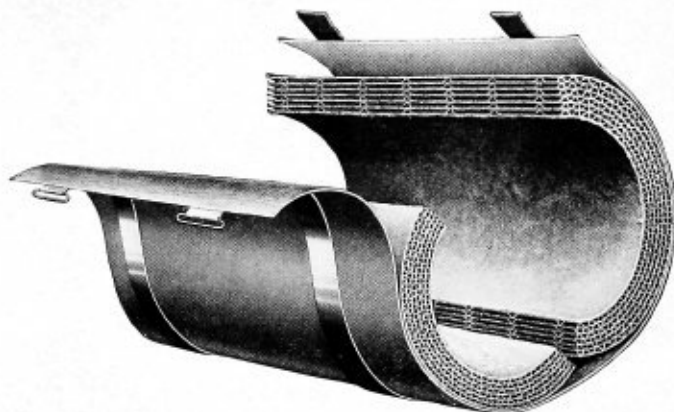

The smaller cells give greater strength and assure increased efficiency.

**F**OR insulating pipes conveying steam at medium or low pressures or for pipes conveying hot water. Johns-Manville Fine Corrugated Improved Asbestocel is a cellular type of insulation made up similar to the Improved Asbestocel described on page 19, except that the corrugations are smaller. However, there are 50% more laminations per inch of thickness and the additional small enclosed air cells provide greater efficiency.

Due to the greater strength of the small cells, Fine Corrugated Improved Asbestocel is even stronger and more durable than Improved Asbestocel.

As a result of smaller cells as described above, the conductivity of Fine Corrugated Improved Asbestocel is lower than that of the regular Improved Asbestocel.

Johns-Manville Fine Corrugated Improved Asbestocel Sectional Pipe Insulation is furnished in 4 and 6 ply thicknesses in 3-foot sections with canvas jacket and brass-lacquered bands to fit standard sizes of pipes.

In order to specify Johns-Manville Fine Corrugated Improved Asbestocel, insert the words, "Fine Corrugated" before the words "Improved Asbestocel" in the specification on the opposite page.

Also furnished in sheet and block form for boilers, flues and other large regular surfaces. Sheets 36" x 36" and blocks 6" x 36", 4" x 18" and 3" x 18", or in special sizes, in thicknesses from 1/2" to 4". For descriptive data on this insulation in sheet and block form, see page 40.

For prices, see price list on page 28.





## Standard Specifications for Insulating Pipes Conveying Low Pressure Steam or Hot Water with Johns-Manville Improved Asbestocel Insulation or Fine Corrugated Improved Asbestocel Insulation

All pipes conveying low-pressure steam or hot water shall be insulated with Johns-Manville Improved Asbestocel Insulation of proper size and thickness. (See note "A.")

All fittings and valves shall be insulated with Johns-Manville Insulating Cement, to be applied to a thickness equal to the adjoining pipe insulation.

All flanges shall be insulated by method "A" or "B," depending upon whether flange insulation is to be removable and replaceable or non-replaceable.

Method "A"—Use suitable size and length of Johns-Manville Improved Asbestocel Sectional Insulation to encircle flanges completely and overlap the adjoining pipe insulation at least two inches (2") on each side of the flange. Secure

this flange covering with wire and fill space between pipe and flange insulation with Johns-Manville Insulating Cement and apply a thin coat of Insulating Cement over entire outside surface of flange cover.

Method "B"—First prime flange surface with a thin coat of Johns-Manville Insulating Cement applied so as to leave a rough surface. When dry follow with successive one-half inch coats of Johns-Manville Insulating Cement until a thickness equal to that of the pipe insulation is obtained.

Each coat of this cement should be allowed to dry before the next coat is applied, and each coat should have a rough surface, except the final coat, which should be trowelled down to a smooth finish.

### Finish of Insulation

All of the above insulation, including fittings, valves and flanges, shall be finally finished and additionally protected with 8-ounce canvas neatly sewed on, over rosin-sized paper, and this canvas painted with either fireproof paint, or lead and oil

paint, of the color desired. This extra canvas cover to be placed over the canvas jacket furnished with the insulation. (When re-canvassing is not desired or considered unnecessary, see note "B.")

### Weatherproof Jacket

If piping is located out-of-doors and exposed to the weather, the additional protection of 8-ounce canvas and paint may be omitted and in its place the insulation shall be protected with a Johns-Manville Asbestos Weatherproof Pipe Insulation Jacket, secured with rings formed of No. 16 copper wire wound once around the jacket and

ends twisted tightly together. These wire rings are to be placed on 4" centers. The jacket is to lap at least 3" in all directions, and all horizontal laps are to be located on the side of the insulation and turned downward in order to shed all water from the surface. (See note "C.")

---

NOTE "A"—Johns-Manville maintains an engineering department at each of its branches, which will, on request, recommend proper thickness for various pressures and temperatures.

NOTE "B"—If insulation is not to be re-canvassed, lacquered bands furnished with the insu-

lation are to be applied, at 18" intervals, on all sectional insulation.

NOTE "C"—When extremely low temperatures are encountered out-of-doors, special recommendations will be given by any Johns-Manville Branch Engineering Department.



## Johns-Manville Asbestos Fire-Felt Sectional Pipe Insulation

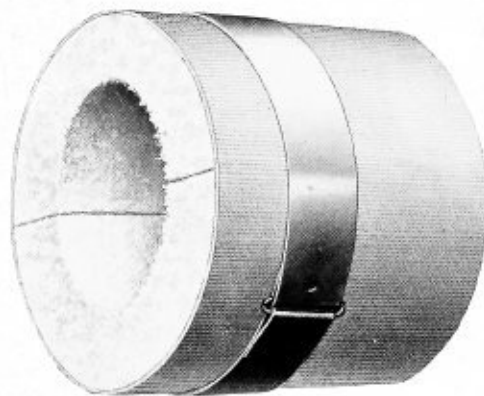

An insulation that is particularly well adapted to high temperatures.

**J**OHNS - MANVILLE Asbestos Fire-Felt Pipe Insulation is composed of asbestos fibre felted together and molded into sections of the required size. This composition assures high heat resisting properties and the process of manufacture produces a strong resilient material of good insulating value, because of the large number of small air cells confined in its structure.

Johns-Manville Asbestos Fire-Felt is unaffected by vibration, expansion and contraction and many other severe conditions common to railroad and industrial plant service.

Due to its high heat resisting properties, Johns-Manville Asbestos Fire-Felt Pipe Insulation is particularly adapted for use on pipes conveying steam at unusually

high temperatures and many other conditions; such as hot oil lines, gas engine exhaust lines, etc., where temperatures are especially high. For such conditions Fire-Felt is usually used for the layer of insulation against the heated surface and Asbestos-Sponge Felted Pipe Insulation is then applied outside of the Fire-Felt. This results in a combination which not only is suited to unusually high temperatures, but also is very efficient.

Johns-Manville Asbestos Fire-Felt is furnished in sections 3 ft. long and in thicknesses of 1" to 3", with canvas jacket and brass lacquered bands, to fit standard sizes of pipe. See approximate weights and price list on page 28.

Also furnished in sheets 24" x 36" and blocks 6" x 36", in thicknesses from 1/2" to 4". For descriptive data, see page 37.



# Johns-Manville Built-up Brine and Ammonia Insulation

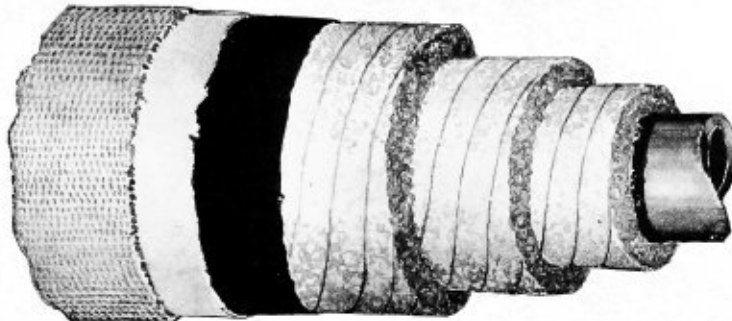

Particularly well adapted to low temperature conditions because of the efficiency and durability of the laminated construction.

**F**OR maintaining the extremely low temperature required in pipe lines conveying brine or ammonia or other cold liquids or gases. Johns-Manville Built-up Brine and Ammonia Insulation consists of several layers of insulating felts carefully applied around pipes to be insulated.

On account of the high insulating qualities of the hair felt used, the flexibility of hair felt and the method of sealing, Johns-Manville Built-up Brine and Ammonia Insulation is not only highly efficient as an insulator, but will withstand contraction and expansion without cracking or break-

ing open. The effective method of sealing eliminates all chance of moisture accumulating between pipe and insulation and then freezing and breaking the insulation open.

This form of insulation should be applied by Johns-Manville. Applied prices quoted on request.

The conductivity of Johns-Manville Brine and Ammonia Insulation is .30 B.t.u., and the conductivity of cork is about .35 B.t.u. per square foot per degree temperature difference per hour per inch thickness.

## HEAT TRANSMISSION THROUGH BUILT-UP BRINE AND AMMONIA INSULATION

The rates of heat transmission given here are expressed in B. t. u. per hour, per degree temperature difference between fluid in the pipe and air surrounding pipe, per linear foot of pipe and per square foot of pipe surface.

Pipe Size	2 LAYER		3 LAYER		4 LAYER	
	Per lin. ft. of pipe	Per sq. ft. of pipe	Per lin. ft. of pipe	Per sq. ft. of pipe	Per lin. ft. of pipe	Per sq. ft. of pipe
1/2 inches.....	.086	.390	.074	.331	.065	.295
3/4 inches.....	.095	.345	.079	.288	.070	.255
1 inches.....	.107	.310	.088	.257	.078	.227
1 1/4 inches.....	.124	.285	.102	.235	.090	.206
1 1/2 inches.....	.132	.265	.109	.218	.095	.190
2 inches.....	.149	.240	.120	.193	.104	.167
2 1/2 inches.....	.167	.222	.133	.177	.114	.151
3 inches.....	.192	.210	.151	.165	.128	.140
3 1/2 inches.....	.211	.201	.165	.157	.138	.132
4 inches.....	.228	.194	.176	.150	.148	.126
4 1/2 inches.....	.247	.188	.190	.145	.158	.121
5 inches.....	.268	.184	.205	.141	.170	.117
6 inches.....	.307	.177	.233	.134	.211	.106
7 inches.....	.343	.172	.257	.129	.230	.102
8 inches.....	.380	.168	.282	.125	.250	.099
9 inches.....	.415	.165	.307	.122	.273	.097
10 inches.....	.455	.162	.335	.119	.292	.111
12 inches.....	.528	.158	.387	.116	.311	.093



## Specifications for Insulating Pipes Containing Brine and Ammonia or Other Cold Liquids or Gases with Johns-Manville Built-up Brine and Ammonia Pipe Insulation

All pipe lines, including fittings and flanges and other apparatus containing brine or ammonia, or other cold liquids or gases, shall be insulated with Johns-Manville Built-up Brine and Ammonia Insulation of the proper thickness. Where temperatures are between 15° F. and 50° F. use two layer insulation and where temperatures are between minus 10° F. and plus 15° F. use three layer insulation.

All piping and other surfaces to be insulated shall be so located that there will be uninterrupted clearance around the finished insulation of at least 3" in all directions. The insulated piping shall not be located closely adjacent to any heated surface nor located in the same pipe chase or shaft with heated pipes.

### PIPES:

All surfaces to be insulated shall be thoroughly cleaned and dried before insulation is applied and the system shall not be put in operation until the insulation work is completed.

Wrap pipes spirally with Johns-Manville Waterproof Membrane so that all surfaces shall be covered with one layer of this membrane. Then apply a layer of 1" Hair Felt cut to proper length so that all longitudinal and abutting joints shall fit closely together and secure this to the pipe by means of a wrapping of two ply wrapping twine wound spirally on approximately 1" centers. Then apply additional layers of 1" Hair Felt in order to give the thickness specified above and apply these so that all longitudinal and abutting joints shall be staggered or broken.

When the proper number of plies have been applied, again wrap spirally with Johns-Manville Waterproof Membrane so that at no place shall it be less than two ply thick. Apply to the surface of the outside waterproof membrane two coats of Johns-Manville Waterproof Sealing Compound, allowing the first coat to set before applying the second.

A sealing cap of waterproof membrane shall enclose the end of the felt insulation wherever it is interrupted by fittings, hangers, etc. These sealing caps shall be at least two ply in thickness and shall extend over the felt and under the out-

side sealing membrane and shall be coated with sealing compound the same as the outside membrane on the pipe.

### FITTINGS:

All fittings shall be insulated separately from the adjacent piping, the insulation being of the same thickness and shall be applied and sealed in the same manner as on the pipe.

The insulation on each fitting or nest of fittings is to be thoroughly sealed in with a sealing membrane not less than two ply thick and joined to the adjacent pipe insulation in such manner that there will be no interruption of insulation of pipes and fittings.

### HANGERS:

Each hanger is to be insulated separately, the same as the fittings, running the insulation along the rod of a hanger for a distance not less than 6" beyond the adjacent pipe insulation.

### ACCUMULATORS, TANKS, ETC.:

Surfaces of accumulators, tanks, etc., shall be insulated in the same manner as specified above for pipe lines, except that extra thicknesses of insulation felts may be required on account of lower temperatures. All exposed ends shall be sealed in with sealing caps.

### FINISH OF INSULATION:

All of the above insulation exposed to view shall be finished with a jacket of 8 oz. canvas, sewed on over a layer of oiled paper and a layer of rosin-sized sheathing paper. This canvas jacket shall be thoroughly sized and painted with not less than two coats of a first quality lead and oil paint.

NOTE: Johns-Manville maintains an Engineering Department at each of its Branches which will, on request, recommend proper thicknesses for various special conditions and temperatures.





## Johns-Manville Anti-Sweat Sectional Pipe Insulation

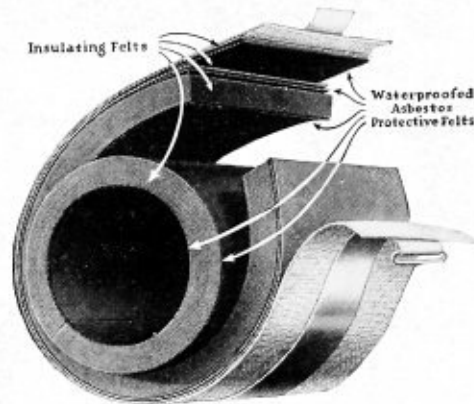

Showing the broken joint construction which eliminates through joints.

**F**OR insulating pipes conveying cold water or other cold liquids at temperatures above 32 degrees Fahrenheit.

Johns-Manville Anti-Sweat Pipe Insulation is a combination of insulating felts that retard the flow of heat and moist air to the pipes, and Asbestos waterproofed felts that protect the insulating felts against the admission of moisture.

The special broken joint construction eliminates longitudinal and abutting joints that extend from the outside of the covering to the pipe in ordinary pipe covering construction. Each section is divided into two equal thicknesses in such a manner that the outer layer can be turned around the inner layer and slipped lengthwise to a position where both the longitudinal and circumferential joints in the outer and inner layers are widely removed from each other. This greatly increases the efficiency and durability of the insulation.

Johns-Manville Anti-Sweat is constructed of insulating felts protected by waterproofed felts, placed where they are most needed: one layer next to the pipe, two layers between the two layers of in-

insulation, and two layers on the outside of the insulation.

Anti-Sweat Insulation performs two important functions. It prevents the warm moist air from coming into contact with the pipe where the moisture from the air would condense and drip off. Such dripping is unsanitary, and also is costly because of damage to merchandise located below the pipes.

The second function of Anti-Sweat Insulation is that by preventing heat absorption by the pipes it keeps the contents of the pipes cold. Where cold drinking water is required, or where cold water is necessary in manufacturing processes, it must be kept cold by insulation or re-cooled mechanically. It costs less to keep water cold than to re-cool it.

Furnished in thicknesses of  $\frac{1}{2}$ ",  $\frac{3}{4}$ ", 1",  $1\frac{1}{2}$ " and 2", in 3-foot sections with canvas jacket and brass-lacquered bands to fit standard pipe sizes.

Not furnished in sheet and block form. See approximate weight and price list on page 28.



## Heat Transmission through Johns-Manville Anti-Sweat Pipe Insulation

Rates of heat transmission are given in B.t.u. per hour per degree temperature difference per linear foot and per sq. foot of pipe surface

Pipe Size	RATES OF HEAT TRANSMISSION									
	1/2" Thick		3/4" Thick		1" Thick		1 1/2" Thick		2" Thick	
	Per Lin. Ft.	Per Sq. Ft.	Per Lin. Ft.	Per Sq. Ft.	Per Lin. Ft.	Per Sq. Ft.	Per Lin. Ft.	Per Sq. Ft.	Per Lin. Ft.	Per Sq. Ft.
1/2"	.212	.963	.185	.841	.167	.758	.143	.642	.128	.581
3/4"	.245	.891	.212	.770	.189	.687	.160	.581	.142	.515
1"	.286	.830	.243	.706	.215	.625	.180	.523	.158	.460
1 1/4"	.338	.777	.284	.653	.249	.572	.206	.473	.180	.413
1 1/2"	.374	.751	.312	.627	.272	.546	.223	.448	.194	.389
2"	.443	.713	.367	.591	.318	.512	.257	.413	.221	.356
2 1/2"	.518	.688	.425	.564	.364	.484	.292	.388	.249	.331
3"	.611	.666	.497	.542	.423	.462	.337	.367	.284	.310
3 1/2"	.685	.655	.553	.528	.468	.447	.369	.353	.311	.297
4"	.757	.643	.611	.518	.515	.437	.404	.343	.338	.287

### Standard Specifications for Insulating Pipes Containing Cold Water

All cold water mains, risers and branches shall be insulated with Johns-Manville Anti-Sweat Insulation 1" thick (for unusually severe conditions, use general recommendations given below) applied in two layers with all joints broken, tightly drawn together and stapled in place. All joints shall be sealed by means of Johns-Manville Moisture-Resisting Cement applied to the edges of the insulation at the joints before they are drawn together. All fittings shall be insulated with Hair Felt of the same thickness as the adjacent pipe insulation. This material shall be cut to fit the fitting and secured in place with close wrapping of heavy jute twine. This insulation on the fittings shall be thoroughly sealed by means of a double wrapping of Johns-Manville Waterproof

Membrane, wound on spirally and coated with Johns-Manville Waterproof Sealing Compound.

All pipe and fitting insulation exposed to view shall be enclosed in an extra jacket of 8-ounce canvas, applied over a lining of heavy rosin-sized paper and sewed in place, seams to be located where least visible.

Where the lines are exposed to the weather this canvas jacket may be omitted, and in its place the insulation shall be protected with a layer of Johns-Manville Asbestos Weatherproof Pipe Insulation Jacket secured with rings of No. 16 gauge copper wire, applied on 4" centers. The jacket shall lap at least 3" in all directions and all horizontal laps are to look downward, in order to shed all water from the surface.

### General Recommendations

The above specification applies to insulation to prevent sweating under normal conditions, i. e., where temperature of water is over 50 degrees F., air temperature is less than 100 degrees F., and the humidity is not over 75%.

To maintain water temperature between 32 degrees and 50 degrees when room temperature is less than 100 degrees F. and humidity of air

is not over 75%, use 1 1/2" thick Anti-Sweat Pipe Insulation.

If humidity is between 75% and 80%, air temperature not over 100 degrees F. and water temperature is not lower than 50 degrees, 1 1/2" thick Anti-Sweat Pipe Insulation should be used.

For more severe conditions, consult Johns-Manville Engineering Department.



## Johns-Manville Zero Sectional Pipe Insulation

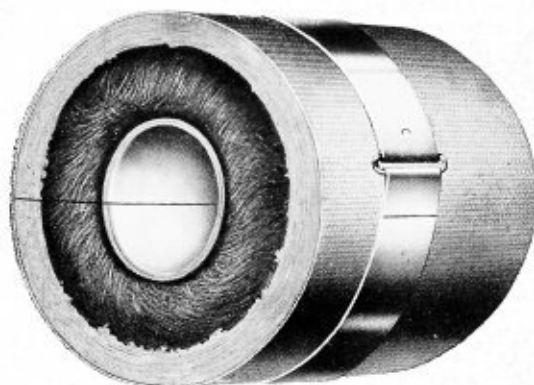

The structure of Johns-Manville Zero Sectional Pipe Insulation adapts it exceptionally well to its special service.

**J**OHNS-MANVILLE Zero Sectional Cold Water Pipe Insulation is constructed of a layer of 1" hair felt surrounded by several layers of wool felt and with a layer of saturated wool felt inside the hair felt. This prevents the hair felt from coming in direct contact with the pipe.

Hair felt, one of the best known non-conductors of heat, greatly retards the flow of heat from the water in the pipe to the cold surrounding air, and the wool felt jacket and the inner layer of saturated felt provide protection for the hair felt lining.

This material is designed and constructed for insulating cold water pipes that are located where there is a likelihood of the water in the pipes freezing but

where temperatures are moderate rather than extreme or where the length of time that the surrounding air would be below freezing-point is short.

Where pipes run out of doors and are subjected to severe conditions or extreme temperatures, Johns-Manville Built-up Hair Felt of suitable thickness should be applied. (See page 42.)

Johns-Manville Zero Sectional Pipe Insulation is furnished in one thickness only (approximately 1 $\frac{1}{4}$ " ) in 3-foot sections with canvas jacket and brass-lacquered bands, to fit standard pipe sizes.

Not furnished in sheet and block form. See approximate weight and price list on page 28.

## Johns-Manville Wool Felt Sectional Pipe Insulation

**A**N inexpensive insulation for cold water pipes. Made of laminations of wool felt in sections 3 ft. long, in three styles:

"Standard"—1" thick, with an inner lining of one layer of asbestos paper.

"Champion" or "Express"— $\frac{3}{4}$ " thick;

same construction as "Standard."

"Aqua" or "C-B"— $\frac{1}{2}$ " thick; same construction as "Standard".

Not furnished in sheet or block form. See next page for approximate weights and list prices.



## Approximate Weights of Johns-Manville Sectional Pipe Insulations

(WEIGHTS GIVEN ARE POUNDS PER STANDARD 3-FOOT SECTION)

Kind of Covering	Thick-ness	Pipe Sizes																	
		1/2"	3/4"	1"	1 1/4"	1 1/2"	2"	2 1/2"	3"	3 1/2"	4"	4 1/2"	5"	6"	7"	8"	9"	10"	12"
Asbestos-Sponge	Std.	4.35	4.70	5.26	6.00	6.42	7.38	8.31	9.52	10.60	11.60	12.50	13.80	15.70	17.70	19.70	21.70	23.80	27.80
	1 1/2"	8.95	9.50	10.40	11.40	12.00	13.30	14.70	16.50	17.90	19.40	20.80	22.70	25.60	28.30	31.00	34.00	37.20	43.00
	2"	13.00	13.60	14.80	16.20	17.00	18.80	20.70	23.10	25.20	27.10	29.00	31.50	35.20	39.10	43.00	47.50	51.30	59.20
85% Magnesia*	3"	25.40	26.50	28.20	29.70	31.60	34.30	37.20	41.00	43.80	46.70	49.70	53.70	59.30	65.20	70.80	76.80	83.50	95.50
	Std.	1.62	1.85	2.02	2.39	2.74	3.77	4.30	5.00	5.57	6.82	7.42	8.05	9.35	11.90	13.20	14.50	16.10	23.00
	1 1/2"	3.77	4.12	4.59	5.10	5.52	6.27	7.16	8.10	8.88	9.70	10.50	11.40	13.10	14.70	16.30	18.00	19.80	23.00
Fire-Felt	2"	6.11	6.75	7.30	7.89	8.40	9.42	10.60	11.90	12.90	14.00	15.20	16.40	18.60	20.80	23.00	25.10	27.50	31.60
	Dbl. Std.	4.86	5.31	5.80	6.42	7.23	9.82	10.90	12.30	13.40	16.40	17.60	19.00	21.50	27.30	29.90	32.60	35.70	50.70
	3"	12.40	13.20	14.00	15.20	16.00	17.40	19.10	21.10	22.60	24.20	25.90	27.70	31.10	34.40	37.50	40.70	44.30	50.70
Improved Asbestocel	4"	4.80	5.06	5.35	6.00	6.40	7.08	7.88	8.80	9.53	10.30	11.10	12.00	13.60	15.20	16.80	18.20	19.90	23.00
	5 ply	9.70	10.10	10.60	11.40	12.00	12.90	14.00	15.40	16.40	17.50	18.50	19.80	22.00	24.20	26.30	28.40	30.70	35.00
	6 ply	13.00	13.60	14.30	15.60	16.40	17.80	19.30	21.30	22.80	24.40	26.00	27.80	31.10	34.30	37.50	40.70	44.20	50.60
Anti-Sweat	1"	23.00	23.80	24.90	27.00	28.20	30.40	32.80	35.90	38.40	40.80	43.40	46.10	51.30	56.20	61.00	66.10	71.40	81.40
	1 1/2"	.90	1.04	1.18	1.37	1.49	1.74	2.02	2.37	2.64	2.92	3.19	3.48	4.05	4.60	5.14	5.68	6.26	7.34
	2"	1.27	1.42	1.60	1.86	2.01	2.37	2.71	3.15	3.50	3.87	4.20	4.60	5.37	6.04	6.75	7.47	8.25	9.65
Aqua Wool Felt	3"	2.00	2.19	2.40	2.69	2.90	3.30	3.74	4.25	4.67	5.09	5.54	6.00	6.89	7.72	8.56	9.41	10.35	12.00
	4"	2.46	2.67	2.90	3.21	3.44	3.90	4.35	4.95	5.40	5.87	6.33	6.85	7.87	8.80	9.75	10.67	11.70	13.60
	5"	3.10	3.32	3.60	4.00	4.30	4.83	5.40	6.10	6.65	7.20	7.75	8.38	9.60	10.70	11.80	13.00	14.20	16.45
Champion Wool Felt	6 ply	3.35	3.70	4.07	4.60	4.98	5.70	6.55	7.50	8.30	9.10	9.87	10.75	12.47	14.00	15.60	17.25	19.00	22.15
	1"	4.10	4.50	5.00	5.60	6.10	7.00	7.93	9.12	10.07	11.00	11.95	13.00	15.05	16.93	18.85	20.70	22.80	26.60
	1 1/2"	7.90	8.40	9.07	9.95	10.58	11.80	13.10	14.70	16.00	17.30	18.60	20.00	22.80	25.27	27.95	30.60	33.40	38.60
Standard Wool Felt	2"	1.40	1.60	1.82	2.08	2.28	2.70	3.15	3.60	4.00	4.50	5.00	5.50	6.00	6.50	7.00	7.50	8.00	8.50
	3"	2.35	2.60	2.90	3.23	3.50	4.10	4.70	5.30	5.90	6.50	7.10	7.70	8.30	8.90	9.50	10.10	10.70	11.30
	4"	3.10	3.63	4.20	4.75	5.30	6.40	7.50	8.50	9.63	10.70	11.80	12.90	14.00	15.10	16.20	17.30	18.40	19.50
Zero	Std.	4.00	4.43	4.88	5.30	5.72	6.67	7.60	8.50	9.40	10.30	11.20	12.10	13.00	13.90	14.80	15.70	16.60	17.50

## List Prices per Linear Foot for Johns-Manville Sectional Pipe Insulation

(READ REMARKS BELOW TABULATION)

Thickness	Inside Diameter of Pipe																Outside Diameter of Pipe							
	1/2"	3/4"	1"	1 1/4"	1 1/2"	2"	2 1/2"	3"	3 1/2"	4"	4 1/2"	5"	6"	7"	8"	9"	10"	12"	14"	16"	18"	20"	24"	30"
Standard Thick	\$.22	\$.24	\$.27	\$.30	\$.33	\$.36	\$.40	\$.45	\$.50	\$.60	\$.65	\$.70	\$.80	1.00	1.10	1.20	1.30	1.85	2.10	2.35	2.60	2.85	3.30	4.00
1 1/2" Thick	.46	.49	.52	.56	.60	.64	.70	.76	.82	.88	.94	1.00	1.10	1.20	1.35	1.50	1.65	1.85	2.10	2.35	2.60	2.85	3.30	4.00
2" Thick	.75	.80	.85	.90	.95	1.00	1.05	1.15	1.25	1.35	1.45	1.55	1.70	1.85	2.00	2.20	2.40	2.70	3.00	3.30	3.60	4.00	4.50	5.50
**Double Standard Thick	.65	.70	.75	.80	.85	.90	1.00	1.10	1.20	1.40	1.50	1.60	1.80	2.25	2.50	2.70	2.90	4.10	4.60	5.10	5.60	6.00	7.00	8.40
3" Thick Broken Joints	1.20	1.35	1.40	1.45	1.55	1.65	1.75	1.90	2.05	2.20	2.35	2.50	2.70	2.90	3.15	3.40	3.65	4.10	4.60	5.10	5.60	6.00	7.00	8.40
Elbows 90° and 45°	\$.30	\$.30	\$.30	\$.30	\$.30	\$.36	\$.42	\$.48	\$.54	\$.60	\$.72	\$.90	1.30	1.80	2.40	3.00	3.60	4.60	5.60	6.60	7.60	8.60	10.60	13.60
Tees	.36	.35	.36	.36	.36	.42	.48	.54	.60	.75	.90	1.20	1.60	2.20	3.00	3.60	4.40	5.60	6.60	7.60	8.60	10.60	13.60	
Crosses	.48	.48	.48	.48	.48	.54	.60	.70	.80	.95	1.10	1.50	2.00	2.80	3.60	4.40	5.20	6.60	7.60	8.60	10.60	13.60	16.60	
Globe Valves	.54	.54	.54	.54	.54	.60	.78	.96	1.20	1.50	1.85	2.25	2.80	3.60	4.40	5.30	6.20	7.60	8.60	9.60	11.60	14.60	17.60	
Flange Covers	.50	.50	.50	.50	.50	.60	.70	.80	.90	1.00	1.30	1.60	1.90	2.20	2.50	2.90	3.30	4.00	4.60	5.20	5.80	6.40	7.00	

\* 85% Magnesia is made in Standard (approx. 1"), 1 1/2", 2", Double Standard Thick and 3" (broken joint) thicknesses. For pipe sizes from and including 14" in diameter it is furnished in segmental form.

\*\* Applies only to 85% Magnesia.

These pipe insulations are supplied in sections three feet long, canvassed and with brass-lacquered bands.

Asbestos-Sponge Felted Insulation is made in thicknesses from 1/2" to 4"; thicknesses 1" and under, use list prices for Standard Thick.

Improved Asbestocel made in 2, 3, 4, 5 and 6 ply. Use Standard Thick list prices for all thicknesses.

Fine Corrugated Improved Asbestocel Insulation is made in 4 ply and 6 ply. Use Standard Thick list prices.

Zero Insulation is made in one thickness only, approximately 1 1/4". Use Standard Thick list prices.

Anti-Sweat Insulation is made in 1/2", 3/4", 1", 1 1/2" and 2" thicknesses; use Standard Thick list prices for all thicknesses under 1".





## The Johns-Manville Underground System of Insulation for Steam and Hot Water Pipes

**T**HE Johns-Manville Underground System of Insulation provides a permanent, efficient and economical means of placing underground and insulating pipes conveying steam or hot water.

The system comprises not only the integral parts shown on page 31, but the proper selection and arrangement of these parts and the installation or supervision

of installation of them by Johns-Manville engineers.

The average efficiency of the Johns-Manville System is at least 90% when installed according to our specifications and by us or under our supervision. This high efficiency is maintained for a long period of time on account of the character of the materials used in the construction.

### Insulating Material Used

For the base of the insulating material which surrounds the pipes we chose asbestos — a natural rock, unchanged by high temperatures, immune to moisture, wear, rot and rust. To provide for maximum insulating efficiency we combined specially selected fibres of this asbestos rock with other material of a sponge-like nature which, when properly mixed with asbestos fibre, forms the most efficient and most durable insulating material for underground work—Johns-Manville Asbestos-Sponge Filling.

The high and lasting heat insulating efficiency of Johns-Manville Asbestos-Sponge Filling is due to the many “dead air” spaces and cells which it confines, and to its base of indestructible asbestos fibre. When packed around the pipe to be insu-

lated, it completely fills the space inside of the protecting and containing parts of the system. It is extremely resilient and spongy, so that there is little tendency for it to settle.

The fact that Johns-Manville Asbestos-Sponge Filling maintains its high initial heat insulating efficiency year after year without depreciation, makes it the most economical insulation possible to use for this work. Its saving of heat does not diminish as time goes on, and it is the “cheapest-per-year” of all underground insulations.

The correct amount and thickness of this insulation has been accurately determined for various conditions by the most rigid tests.

### Supporting Roll Frame

The Johns-Manville Supporting Roll Frame has been designed to provide support for the pipes and to insure that they may move freely when expanding and contracting.

This roll frame, anchored in a concrete

base, supports the entire weight of the pipes and their contents and prevents any load from being carried by the containing and protecting member. The movements of the pipes due to expansion and contraction thus produce no effect on the sys-



tem. This method of support is sufficient to bear any weight required of it in service. Johns - Manville Roll Frames are de-

signed and made according to the number and combination of pipes that may be contained in the conduit.

## Supporting Sections

The supporting section of the system is a most important part as it completely covers and encloses the roll frame and the

concrete base in which the roll frame is embedded and also acts as a connecting link between the containing sections.

## Containing Sections

The supporting sections are connected by containing sections, which complete the continuous stone protective member which surrounds the entire system and acts as a container for the Asbesto-Sponge Filling. The sections are split diagonally, so

that the lateral joints will shed water better than if the cut of the joint were straight, and each half of every section is numbered so that in the installation of the system mates of each section will always be placed together.

## Underdrain

Provision is made to prevent water from accumulating around the system and to drain or carry it away by the use of an underdrain of small tile pipe laid with open joints and embedded in crushed stone, which is carried up and around the system to a point above the lateral joints.

The design and proper location of anchors, anchor-pits, manholes and manhole covers are details carefully worked out by our engineers according to conditions.

Manholes or pits are used as required by the nature of the installation. In a small installation there is no call for a large manhole, as the pipes may be anchored or a branch may be taken off in a small pit (commonly called a blind pit)

to which no ready means of access is necessary.

Wherever there may be valves, expansion joints, flanged joints, or other features which it may be desirable or necessary to get at occasionally, and which cannot be placed in a building into which the system runs, a manhole with a removable but water-tight cover should be employed.

Where any part of the system terminates, whether at a building, anchor-pit or manhole, the ends are sealed in by specially designed shutters.

See pages 33 and 34 for detailed specifications.



Integral Parts of the Johns-Manville Underground System of Insulation

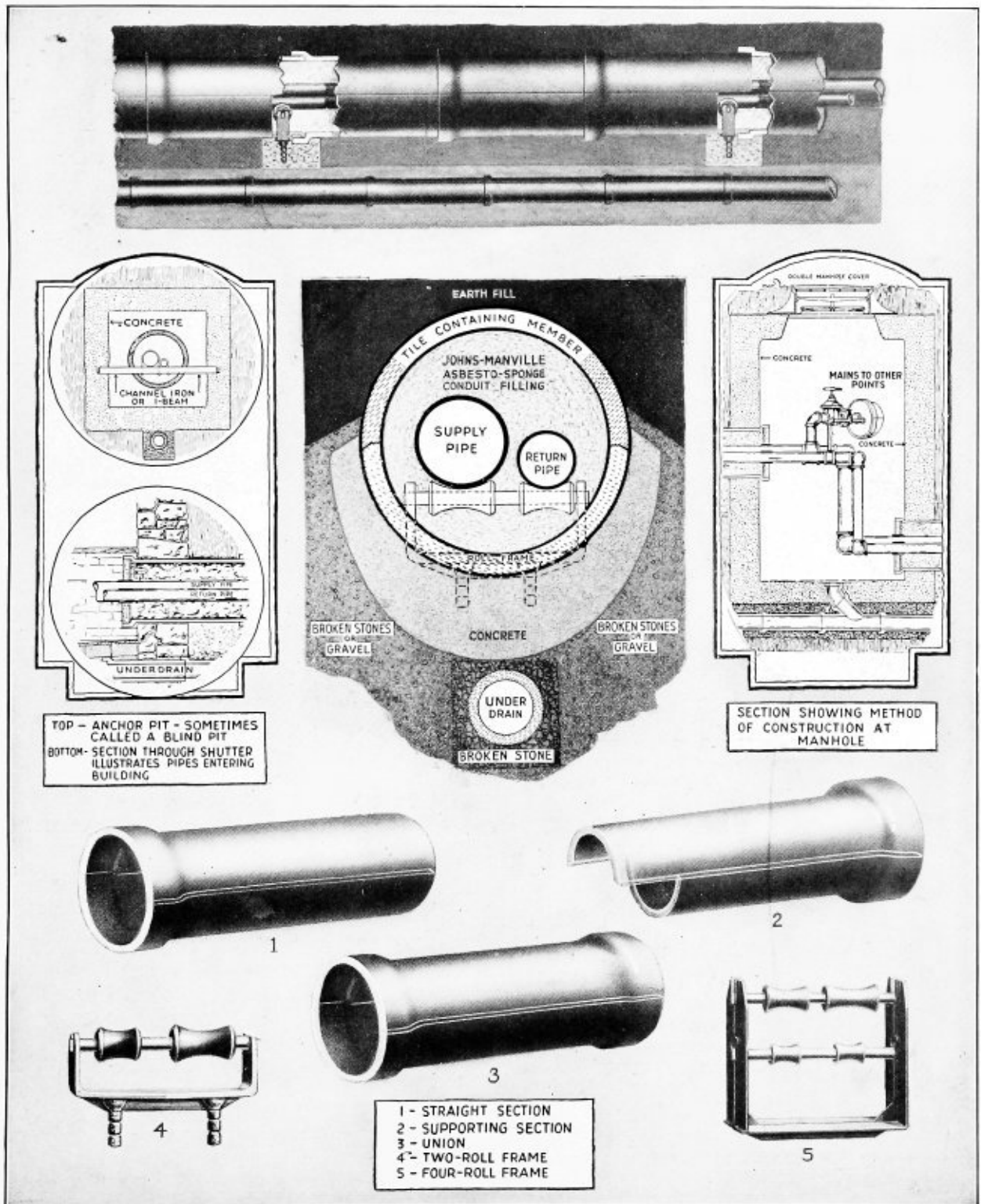



## Johns-Manville Service to Industry



# The Johns-Manville Underground System of Insulation in Course of Installation

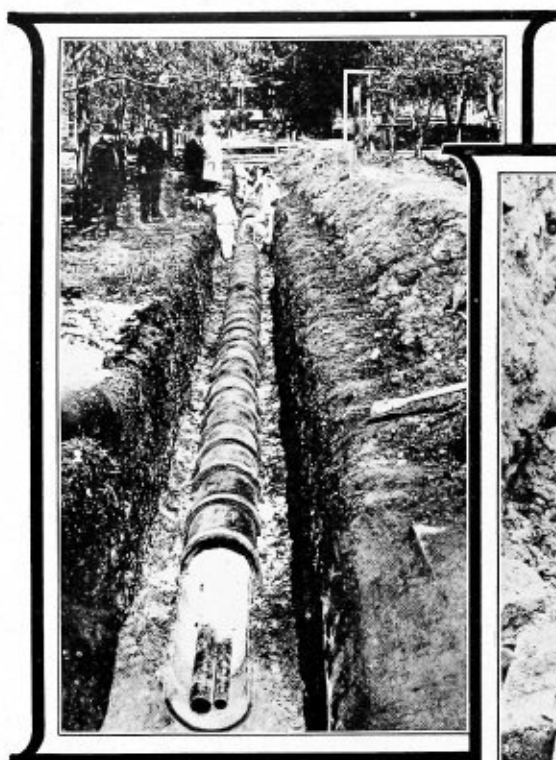

Above—Pipes being insulated before top of system is applied at Battle Creek Sanitarium Battle Creek, Mich.

Below—Roll Frame supporting steam lines in system installed at Stevens Institute Hoboken, N. J.

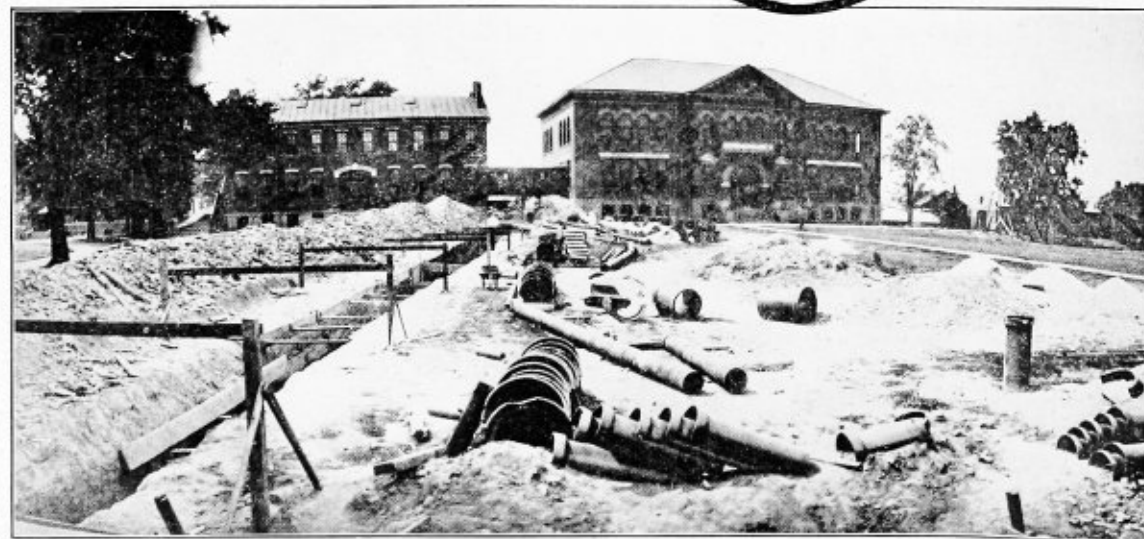
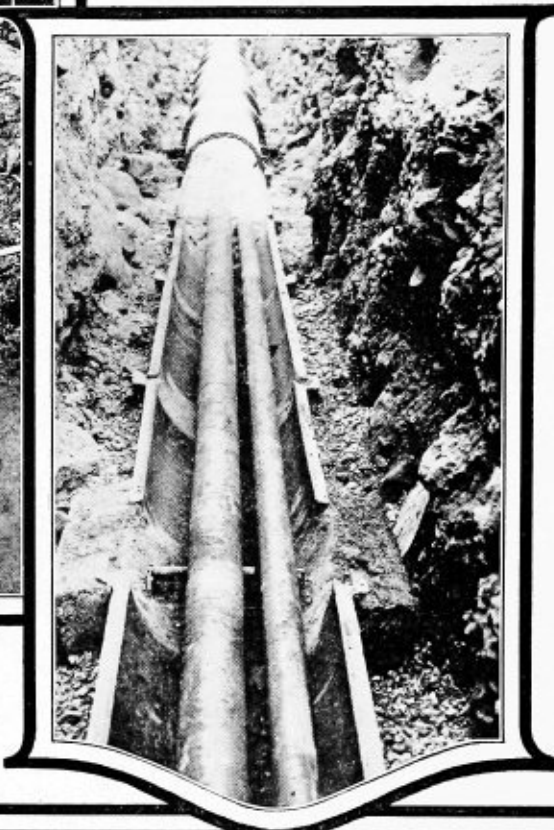

Sections being split before being placed in trench at Pennsylvania Reform School, Morgantown, Pa.





## Specifications for Steam and Hot Water Pipes to Be Installed Underground

1. All steam lines and returns and all hot water lines that run outside of power plant or buildings shall, as indicated, be run underground and insulated by the Johns-Manville System of Underground Insulation.

2. This system shall consist of:

- (a) Roll frames and rolls for the support of piping.
- (b) Supporting sections for the enclosure and support of the roll frames.
- (c) Straight sections and unions for the connections between supporting sections and buildings or pits.
- (d) Johns-Manville Asbesto-Sponge Filling for the insulation of the pipes.
- (e) Underdrain for drainage of system.
- (f) Broken stone or gravel of suitable size for surrounding lower half of system.
- (g) Shutters to seal the ends of the system where it terminates in buildings, manholes or pits.
- (h) Manholes and anchor pits to be provided as indicated to allow for control of expansion and contraction or for changes in direction or elevation of the system.
- (i) Suitable covers for manholes.

The system complete and when installed shall provide for the support of pipe or pipes at proper intervals, so that neither the weight of the pipe nor the movement of same due to expansion or contraction will cause strain or stress to come on the tile containing members of the system.

The containing members, (b) and (c), paragraph 2, shall be of a size that will provide not less than three inches of space for insulation between the top of pipe or pipes and the nearest point of the containing member, and between the side of pipe or pipes and nearest point of containing member. The space referred to, to be measured between the outside surface of the pipe and inside surface of the containing member.

The supporting sections shall be so designed and made as to provide a suitable concrete base extending from the broken stone or gravel bedding under the containing members up through the special opening to the interior of the containing members, and the roll frames are to be set into these bases when they are built.

The entire space in the containing member not occupied by pipe, rolls and roll frames to be filled with Asbesto-Sponge Filling, a proper combination of asbestos and suitable material of a spongy nature.

3. All material listed under items (a) to (e) inclusive, and item (i) paragraph 2, to be furnished by Johns-Manville Inc.

4. Material listed under items (f), (g) and (h), paragraph 2, to be furnished by party agreed upon and stipulated hereafter.

### Material

### Supervision of Installation

5. Johns-Manville Inc. shall furnish a representative capable of supervising the installation of the system above described and all work done by the labor required to install the system is subject to the approval of the Johns-Manville representative, whether said labor be furnished by Johns-Manville Inc. or otherwise, as stipulated hereafter.

6. All labor and tools required for the digging of trenches for the system, the handling of broken stone or gravel, the back-filling of trenches after the insulation of piping has been completed, and for the actual installation of the various parts of the system, shall be furnished by the party or parties stipulated hereafter.

### NOTE TO ARCHITECT OR ENGINEER SPECIFYING

When possible it is advisable to consult with the engineering department at the nearest Johns-Manville branch regarding the selection of party or parties referred to in paragraphs 4, 5 and 6, as local con-

ditions, the size of the installation, and the location of same have much to do with the selection of parties best qualified to handle various parts of the installation.

Whenever possible Johns - Manville



recommends and desires to furnish its own men as well as a superintendent to install all items (a) to (g) inclusive, paragraph 2. There may be exceptions such as the installations of systems at some distant or

out of the way place or at some institution that desires to furnish its own labor. In all cases, however, the installation of the system must be under the supervision of Johns-Manville Inc.

## Levels and Lines

7. Unless otherwise agreed, levels and lines for laying the system to true and proper grade shall be furnished by the engineer or owner.

The batter boards indicating such lines and levels shall be furnished and set at intervals of about 33 feet by the engineer or owner.

## The Installing or Laying of Pipes to Be Insulated

8. It is to be understood by the steam-fitter or contractor who is to furnish and install the piping to be insulated by the Johns-Manville System, that no flanges, companion flanges or flanged fittings are to be used where pipe is surrounded by the underground insulation, and that all such connections are to be made with extra-heavy screw couplings or welded connections according to heating or steam-piping specifications covering that work.

Furthermore, the piping shall be placed and connected on rolls, as they are provided by party installing same, as soon as said rolls have been installed and are ready for the pipe. And before the Asbesto-Sponge Filling and top halves of the system are in place, the steam-fitter or contractor placing the piping shall subject the pipe placed to a hydrostatic test mutually agreed upon by the owner and Johns-Manville Inc.

In case any leaks or defects develop when pipe is subjected to test, such repairs or replacements as are satisfactory to Johns-Manville Inc. are to be made before the system is insulated and the top halves applied.

All pipes to be anchored with suitable anchoring devices furnished by the steam-fitter and proper provision made for expansion as shown in plans and specifications.

Where pipes are run through walls or through shutters—item (g) paragraph 2—where the system or part of same begins and terminates, the steam-fitter shall furnish and place around pipe, sleeves made of the next size of pipe that may be slipped over pipe to be insulated, and these sleeves shall be of such a length as to extend entirely through wall or shutter and from two to four inches beyond each side of wall or shutter.

## NOTE TO ARCHITECT OR ENGINEER SPECIFYING

Next and finally, stipulate party or parties to provide labor and materials mentioned in paragraphs 4, 5 and 6.



## Johns-Manville Asbesto-Sponge Felted Sheets and Blocks

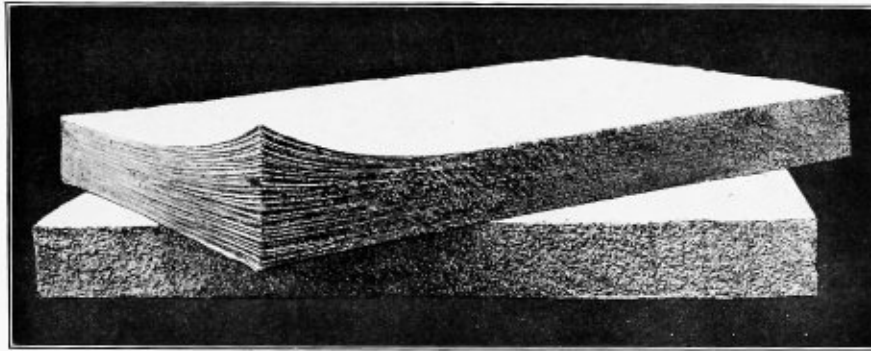

Illustration shows laminated construction of this material.

**F**OR efficiently insulating any surface to which these sheets may be fitted, providing the temperature of the surface to which the material is applied does not exceed 750° Fahrenheit.

Johns-Manville Asbesto-Sponge Felted Sheets and Blocks are constructed by building up to the required size and thickness a number of sheets of Asbesto-Sponge Felt of the same kind as used in the manufacture of Asbesto-Sponge Felted Pipe Insulation.

The remarkable efficiency of this material is due to the enormous number of minute confined dead air spaces in the felt itself as well as the dead air spaces formed between the layers of the felt as built up to produce the finished product.

The advantages of Asbesto-Sponge Felted Insulation lie in its high efficiency and the fact that it retains this high efficiency throughout its long life.

On account of the materials used and the manner of constructing Asbesto-Sponge Felted Sheets and Blocks they

withstand vibration, shocks, and the rough usage of shipment and general handling without crumbling, pulverizing or the loss of value or efficiency so common to moulded and similar insulations. They can be removed and replaced without injury.

Asbesto-Sponge Felted Sheets and Blocks are flexible and conform to curved surfaces of boilers, tanks, etc., without the necessity of moulding specially for each required radius which is necessary in the case of moulded insulation.

The relatively large sizes in which Asbesto-Sponge Felted Sheets are furnished assure fewer joints and less time and labor for application than in the case of materials which are furnished only in block form.

Furnished in sheets 24" x 36" and blocks 6" x 36", from 1/2" to 4" in thickness.

For efficiencies of Johns-Manville Asbesto-Sponge Felted Sheets and Blocks, see page 44. For approximate weights and list prices, see page 45.



## Johns-Manville 85% Magnesia Blocks

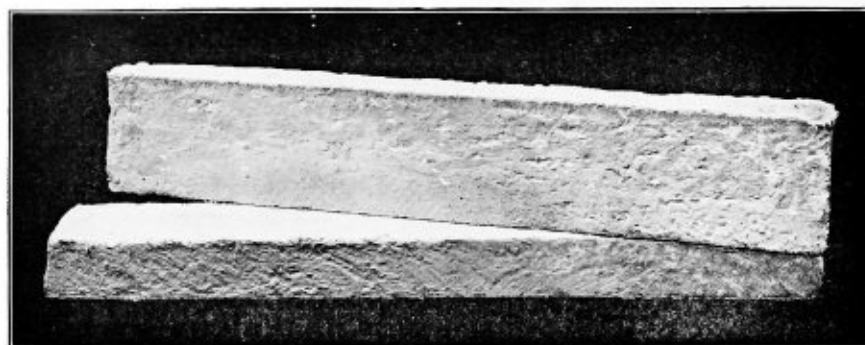

For insulating flat, curved and irregular surfaces.

**J**OHNS - MANVILLE 85% Magnesia Blocks are composed of 85% carbonate of magnesia and 15% asbestos fibre, molded into block form. The Johns-Manville manufacturing process produces an 85% Magnesia with the maximum number of voids or minute dead-air cells which increase its natural resistance to heat transmission and reduce its weight. In addition, this process provides maximum mechanical strength consistent with high efficiency.

This material is particularly adapted to conditions where it is necessary to use material that is light in weight, or where surfaces are so irregular that it is necessary to use a material that can be broken in order to apply it to the irregularities.

However, unless this form of block insulation is protected by an air space or some other material with greater heat-resisting qualities, it is not advisable to apply it to surfaces where temperatures exceed 600° F.

The effect on this material of temperatures above 550° F. is to "calcine" it, which changes the material to magnesium oxide with a resulting shrinkage of about 15%, and breaks down the crystalline

structure to which the material owes its strength. This shrinkage which takes place opens up the joints and cracks the material so that heat can leak out through the cracks. Where an insulation of high heat-resisting properties is required, 85% Magnesia may be applied over a layer of Fire-Felt with the result that a highly efficient combination is obtained, yet one which will withstand higher temperatures than those to which the more efficient material may be applied direct.

Among the places where such combinations are particularly desirable are furnace walls, oil stills and other apparatus operated at temperatures too severe for most other insulating materials.

Its greater efficiency naturally affords a greater saving and the fact that it is lighter and stronger than competitive magnesia reduces breakage loss in transit and application to the minimum.

Furnished in blocks 3" x 18" and 6" x 36", from 1/2" to 4" in thickness.

For efficiencies of Johns-Manville 85% Magnesia Blocks, see page 44.

See approximate weights and price list on page 45.





## Johns-Manville Asbestos Fire-Felt Sheets and Blocks

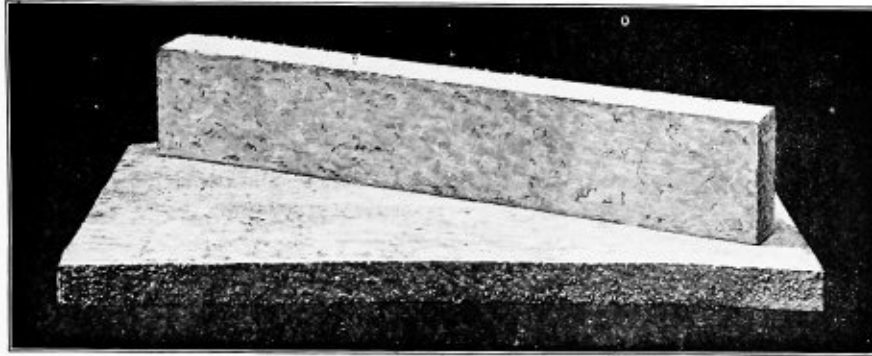

An asbestos material especially adapted to insulating extremely hot surfaces.

**J**OHNS-MANVILLE Fire-Felt Sheets and Blocks are made by felting and moulding asbestos fibre into sheet or block form. The process used in the manufacture of Johns-Manville Fire-Felt produces a heat resisting material of good insulating value, that is strong and resilient, and that will not readily powder or crumble even when applied to surfaces that move or vibrate.

Johns-Manville Fire-Felt, due to its strength, durability and high heat resisting qualities is particularly adaptable to many uses where the conditions are unusually severe, such as the lining of breechings or flues where the temperatures are particularly high, and the lining of boiler tube doors where considerable mechanical strength is required to withstand the vibration due to opening and closing of doors.

Another use to which Johns-Manville Fire-Felt is especially adapted is for the first layer of insulation applied on a highly heated surface where a material of high heat resisting properties is required. Then more efficient Johns-Manville insulating materials, such as Asbesto-Sponge Felted, 85% Magnesia, or Fine Corrugated Asbestocel may be applied over the layer of

Fire-Felt with the result that a highly efficient combination is obtained which will withstand higher temperatures than those to which the more efficient materials may be applied direct.

Among the places where such combinations are particularly desirable are furnace walls, oil stills and other apparatus operated at temperatures too severe for most other insulating materials.

Johns-Manville Fire-Felt is furnished in standard sheets 24" x 36" and blocks 6" x 36", in thicknesses from  $\frac{1}{2}$ " to 4".

The sheets may be furnished curved to radius in order to fit the surface to be insulated. This permits of using full sized sheets on curved surfaces, instead of small blocks.

A decided advantage in the use of Johns-Manville Fire-Felt in large sized sheets is that this permits of application with only a few joints, as compared with the large number required with a material furnished only in small blocks. This results in higher efficiency, because the elimination of joints eliminates a large source of heat loss.

See approximate weights and price list on page 45.



## Johns-Manville Thermo Fire-Felt Sheets and Blocks

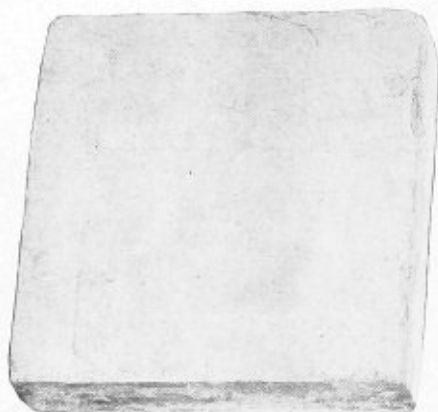

Exterior of sheet.



Section of block showing cellular center.

**A**N improved, efficient sheet or block for insulating hot blast stoves in steel plants, kilns and furnaces, breechings, flues, boiler walls, etc.

Made by felting and molding asbestos fibre into sheets of proper size and thickness with a cellular structure embedded in the center of each sheet. This cellular structure does not extend to the edges of the sheet, but is completely sealed in, the efficiency of the material being increased by the confined air spaces.

In addition to giving increased efficiency the cellular structure also adds strength and the desirable resiliency, which makes Johns-Manville Thermo Fire-Felt especially suited to conditions where expansion and contraction are large factors.

The application of Johns-Manville Thermo Fire-Felt in large sheets gives this material a decided advantage over materials furnished only in small blocks, because large sheets require few joints, as compared with the large number required in the case of small blocks. Fewer joints mean higher efficiency, because joints permit a large proportion of heat loss.

Johns-Manville Thermo Fire-Felt is furnished in standard sheets 24" x 36", in thickness from 1½" to 4". May be furnished also in curved sheets or sheets of special size.

For efficiencies see page 44. See approximate weights and price list on page 45.

## Johns-Manville Vitro Fire-Felt Sheets and Blocks

**F**OR the insulation of hot blast mains and bustle pipes or particularly severe heat conditions, the use of Johns-Manville Vitro Fire-Felt between the shell and fire-brick is recommended.

Johns-Manville Vitro Fire-Felt is similar in construction to Thermo Fire-Felt with the exception that the embedded cell-

ular structure is more rigid and has greater heat-resisting qualities.

Furnished standard in sheets 24" x 36", in thicknesses from 1½" to 4". May be made in curved sheets or in sheets of special size. See approximate weights and price list on page 45.



## Johns-Manville Vitribestos Sheets and Blocks



Curved sheets for lining stacks and circular ducts.

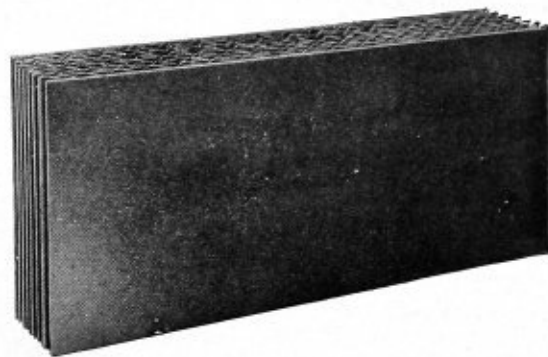

Flat sheets for lining breechings, square ducts, etc.

**F**OR lining smokestacks and flues, building theatre curtains and for use where a strong, stiff, insulating sheet or block is required that will resist temperatures up to 800° F.

Johns-Manville Vitribestos is made of asbestos felts which have been corrugated and built up to form a cellular sheet. These sheets are subjected to a treatment and process which vitrifies them and makes them more resistant to moisture and high temperatures than other cellular sheets which have not been vitrified.

The vitrified sheet has not, however, as great an insulating value as untreated sheets and its use should, therefore, be confined to those places which require the qualities referred to above.

Johns-Manville Vitribestos Sheets are made either flat or curved to any radius and on account of their insulating value are admirably adapted to use as a stack lining. They are especially adapted to the lining of steel stacks on account of their light weight.

Drawings showing arrangement of curved steel angles that provide for the easy application of stack lining will be furnished upon request.

Vitribestos when used as a flue lining or in fireproof construction is held in place and supported by bolts or steel angles, the application of which depends upon the type of construction required. Full particulars and details will be furnished by any Johns-Manville branch.



## Johns-Manville Improved Asbestocel Sheets and Blocks

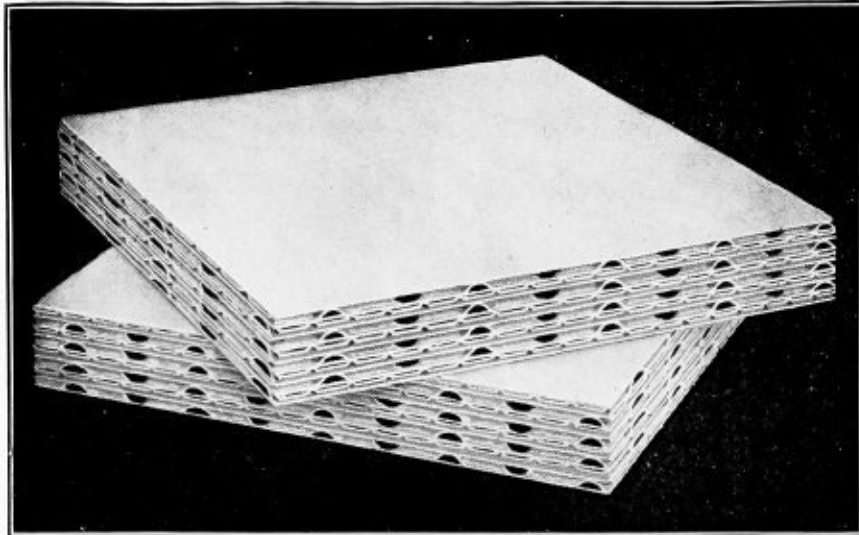

A particularly efficient sheet and block insulation that is light in weight and durable.

**F**OR insulating medium or low pressure boilers, feed-water heaters, drying rooms and other surfaces where temperatures are not extreme.

Made of plain and corrugated asbestos felts built up one upon another until proper thickness of cellular structure is obtained.

In each ply the latter is corrugated in two directions; that is, the corrugations or cells which run lengthwise are divided into a number of distinctly separate cells by corrugations which run at right angles to them.

This unique construction provides a multitude of dead air cells, because the corrugations prevent any circulation of air. In ordinary air cell the air is free to

circulate in the cells and leak out when the expansion causes the ends to separate.

For this reason Improved Asbestocel sheets and blocks which cost about the same as ordinary air cell, lose 10 to 15% less heat than ordinary air cell.

Another advantage of Improved Asbestocel is that the arches formed by the corrugations give it greater strength and greater durability.

Asbestos Felt offers high resistance to heat and this cellular form provides particularly good insulation.

Furnished in standard sheets, coarse or fine corrugated, 36" x 36", or blocks 6" x 36", 3" x 18" and 4" x 18", from 1/2" to 4" in thickness. See approximate weights and price list on page 45.





# Johns-Manville Asbestos Roll Fire-Felt

(Plain or Indented)

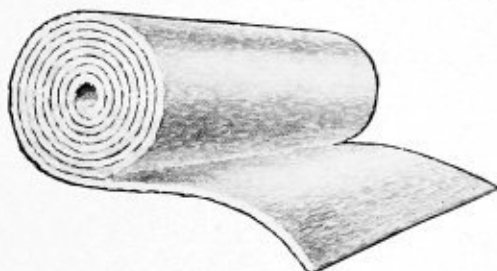

On account of its great flexibility, its insulating and heat resisting properties, Asbestos Roll Fire-Felt is adaptable to a wide variety of uses.

**P**LAIN—A soft, flexible felt of asbestos fibre, used where there is need of an insulating and heat-resisting felt that may be folded, bent or wrapped around pipes and heated surfaces.

It is especially adapted to wrapping around pipes which are too close to adjacent pipes, other equipment, or partitions to permit the use of sectional covering.

**INDENTED**—Made of the same material as plain Roll Fire-Felt, but the surface of one side is indented at close intervals over its entire area.

These indentations make the sheet more flexible and easily bent to a small radius.

The indented construction also provides greater confinement of dead air spaces when the insulation is wrapped or built up on surfaces to be insulated. It is, therefore, more efficient than the plain material.

Both plain and indented Fire-Felt are furnished in thicknesses of  $\frac{3}{32}$ " ,  $\frac{1}{8}$ " ,  $\frac{3}{16}$ " ,  $\frac{1}{4}$ " and  $\frac{3}{8}$ " , in rolls 3 ft. wide containing approximately 100 sq. ft. See page 45 for approximate weights.

Thickness	Per Sq. Ft. List Price
$\frac{3}{32}$ " thick.....	\$0.16
$\frac{1}{8}$ " thick.....	.20
$\frac{3}{16}$ " thick.....	.26
$\frac{1}{4}$ " thick.....	.30
$\frac{3}{8}$ " thick.....	.50

# Johns-Manville Asbestocel

(In Flexible Roll Form)

**J**OHNS - MANVILLE Asbestocel in flexible roll form is made by fastening together a plain and a corrugated asbestos sheet.

It is applied by wrapping one or more times around the pipe to be insulated and fastened on with wire wound around it spirally. Additional fastening should be provided by wire rings placed about every 18 inches. At least two layers of Asbestocel should be applied on warm-air furnace pipes.

To provide a neater finished appearance asbestos paper may be pasted over the sur-

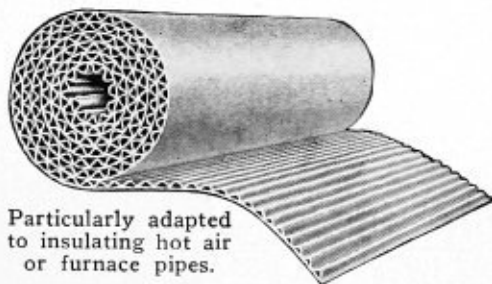

Particularly adapted to insulating hot air or furnace pipes.

face of the Asbestocel after it has been wired on.

Furnished in rolls 3 feet wide containing approximately 250 square feet.

List Price, 1 Ply (about  $\frac{1}{4}$ " thick) \$0.10 per sq. ft.



# Johns-Manville Standard Hair Felt Insulation



Superior to other flexible insulations because it does not deteriorate through age.

**J**OHNS-MANVILLE Standard Hair Felt is made of cattle hair, carefully selected and chemically cleaned. An improved process is used in the manufacture, resulting in a perfectly combined felt which is not subject to disintegration. It

is widely used for refrigerator insulation and for insulating both hot and cold water pipes. Put up in bales 6 ft. wide containing 300 sq. ft. Can be furnished 3 ft. wide, containing 150 sq. ft. An extra charge is made for cutting less than 300 sq. ft.

### LIST PRICES AND APPROXIMATE WEIGHTS

Thickness	Price Per Sq. Ft.	Weight Per Sq. Ft.	Weight Per Bale
1/4 inch.....	\$0.06 1/2	4 ounces.....	75 pounds
1/2 ".....	.08	6 ".....	112 1/2 "
3/4 ".....	.10	9 ".....	170 "
1 ".....	.12	12 ".....	225 "
1 1/2 ".....	.18	18 ".....	337 "
2 ".....	.24	24 ".....	450 "

# Johns-Manville Built-up Hair-Felt Insulation

**J**OHNS-MANVILLE applies built-up hair felt insulation in required thickness and number of layers to prevent the freezing of pipes conveying water and subjected to severe conditions.

As flow of water, duration of low temperatures and other factors have much to do with the thickness and method of application, each case should be referred to the nearest Johns-Manville Branch.



# Johns-Manville Asbestos Sheet Millboard

**F**OR general use where sheet or board is desired for protection against fire, heat, acid fumes, etc. Made of asbestos fibre and suitable binders. Extensively used for lining doors, partitions and floors, and for a variety of heat-resisting purposes in factories, mills and power

plants where fire protection is desired.

Standard sheets, 40" x 40", 42" x 44", and 48" x 48".

Made in three grades: Hard, medium and soft. Medium furnished unless otherwise specified. Prices on application.



This insulation can be cut to any size desired and fastened with nails or screws.

## WEIGHTS OF JOHNS-MANVILLE ASBESTOS SHEET MILLBOARD

Thickness	Weights Per Sheet 40" x 40"	Weights Per Sq. Ft.
1/32-inch	2.4 pounds	3.4 ounces
3/64-inch	2.75 pounds	4 ounces
1/16-inch	3.65 pounds	5.3 ounces
5/64-inch	5 pounds	7.2 ounces
3/32-inch	5.5 pounds	8 ounces
1/8-inch	7 pounds	10 ounces
5/32-inch	9 pounds	13 ounces
3/16-inch	10 pounds	14.4 ounces
1/4-inch	14 pounds	20.2 ounces
5/16-inch	17 pounds	24.5 ounces
3/8-inch	20 pounds	28.8 ounces
1/2-inch	25 pounds	36 ounces

# Johns-Manville Asbestos Paper and Roll Board

The uses of Johns-Manville Asbestos Paper are large and varied; in general, it is used as a fire retardant. Its thinness makes it necessarily less efficient as an insulator than either Johns-Manville Asbes-

tocel in flexible roll form or Johns-Manville Roll Fire-Felt, and in order to obtain appreciable insulating effect, if used for that purpose, several wraps are necessary. Prices on application.

Approximate Weight per 100 Square Feet	Approximate Thickness Inches
<b>ASBESTOS PAPER:</b>	
6 pounds	.015
8 pounds	.018
10 pounds	.020
12 pounds	.025
14 pounds	.028
16 pounds	1/32
35 pounds	1/16
<b>ASBESTOS ROLL BOARD:</b>	
53 pounds	3/32
68 pounds	1/8



For use when insulating material of minimum thickness is required.



## What Insulation Efficiency Means

The efficiency of insulating material is expressed by a percentage, which is the percent of heat saved by using the insulation, as compared to what would be lost if no insulation were used and the surface left bare or uninsulated.

The efficiencies of all insulations vary according to the temperature difference between the

surface and the surrounding air, as well as according to the thickness of the insulation.

Complete information regarding the use of efficiency tables, with example to illustrate will be found on page 243.

For table showing the total heat lost from bare surfaces, see page 244.

### EFFICIENCIES OF JOHNS-MANVILLE ASBESTO-SPONGE FELTED SHEETS AND BLOCKS

Thickness of Insulation	Temperature Difference between Hot Surface and Surrounding Air									
	50°	100°	150°	200°	250°	300°	350°	400°	450°	500°
	Per Cent. Efficiencies									
1" .....	82.90%	84.17%	85.42%	86.57%	87.50%	88.38%	89.28%	90.10%	90.92%	91.73%
1½" .....	87.88	88.77	89.67	90.44	91.15	91.78	92.40	92.98	93.56	94.14
2" .....	90.04	91.32	92.00	92.61	93.12	93.61	94.10	94.55	95.00	95.44
2½" .....	92.36	92.92	93.46	93.96	94.39	94.79	95.19	95.55	95.91	96.28
3" .....	93.54	94.02	94.49	94.91	95.25	95.59	95.92	96.23	96.54	96.85

### EFFICIENCIES OF JOHNS-MANVILLE 85% MAGNESIA BLOCKS

Thickness of Insulation	Temperature Difference between Hot Surface and Surrounding Air									
	50°	100°	150°	200°	250°	300°	350°	400°	450°	500°
	Per Cent. Efficiencies									
1" .....	80.80%	82.36%	83.90%	85.21%	86.48%	87.60%	88.70%	89.64%	90.56%	91.48%
1½" .....	86.25	87.40	88.53	89.49	90.37	91.16	91.94	92.65	93.32	93.97
2" .....	89.32	90.16	91.08	91.85	92.53	93.12	93.71	94.27	94.80	95.31
2½" .....	91.19	91.95	92.69	93.32	93.87	94.38	94.87	95.31	95.73	96.14
3" .....	92.55	93.22	93.83	94.37	94.82	95.25	95.67	96.06	96.40	96.75

### EFFICIENCIES OF JOHNS-MANVILLE THERMO FIRE-FELT SHEETS AND BLOCKS

Thickness of Insulation	Temperature Difference between Hot Surface and Surrounding Air									
	50°	100°	150°	200°	250°	300°	350°	400°	450°	500°
	Per Cent. Efficiencies									
1½" .....	78.70%	80.55%	82.30%	83.81%	85.10%	86.27%	87.42%	88.48%	89.50%	90.50%
2" .....	83.27	84.64	86.00	87.18	88.20	89.14	90.08	90.92	91.73	92.51
2½" .....	86.09	87.23	88.37	89.39	90.27	91.03	91.79	92.48	93.17	93.82
3" .....	88.14	89.08	90.02	90.92	91.66	92.33	93.00	93.57	94.17	94.72

The above efficiencies are based on the application of sheets to flat surfaces. They are approximately correct however for curved surfaces, curved to large radius, such as boiler drums, tanks, etc.

## Example

What is the efficiency of Asbesto-Sponge Felted Insulation 3" thick to be applied on a surface at a temperature of 450° F. in a room where temperature is 70° F.?

The temperature difference is 450° F.—70° F.=380°.

Refer to table of Efficiencies for Asbesto-Sponge Felted Insulation (on this page). Efficiency for

400° F. temperature difference is..... 96.23%

350° F. temperature difference is..... 95.92%

Difference for 50°..... 0.31%

If difference for 50° F. is .31% then for 1°, difference is .31% ÷ 50 = .006%.

The difference (380°) is 30° more than 350°, so 30 × .006% = .18%, which added to 95.92% = 96.1%; the required efficiency.

To find exactly how much heat is saved by applying this insulation, proceed as follows:

Refer to table giving total heat loss in B.t.u. per square foot of bare surface (page 244).

Under temperature difference of 400°, you find loss is 1614.0 B.t.u. per hour, and under 350° difference loss is 1269.4. The difference in loss for the 50° difference

is 1614.0—1269.4=344.6 B.t.u., and for one degree difference it is 344.6 ÷ 50 = 6.89 B.t.u.

The difference you have (380°) is 30° more than 350, so 30 × 6.89 = 206.7 B.t.u., which added to 1269.4 = 1476.1 B.t.u., the required total heat loss from one square foot of bare surface per hour.

Having obtained the loss for bare surface, the saving effected by the 3" Asbesto-Sponge Felted Insulation is obtained by multiplying the total loss, 1476.1 B.t.u., by the efficiency of the insulation previously found (96.1%) or 96.1% of 1476.1 = 1418.5 B. t. u. saved per square foot per hour.

Results obtained by different thicknesses of insulation or different types of insulation are best determined by comparing heat losses through each.

In order to find the heat loss through the insulation in the above example proceed as follows:

Bare surface loss = 1476.1 B. t. u. per sq. ft. per hr.  
Efficiency = 96.1

Percent loss = 100 — 96.1 = 3.9%

Loss through insulation = 3.9% of 1476.1 = 57.6 B. t. u. per sq. ft. per hr.





## Johns-Manville Sheet and Block Insulation

### Approximate Weights and Standard Sizes

Material	Standard Sizes	Thickness	Lbs. per Sq. Ft.
Asbesto-Sponge Felted Sheets and Blocks.....	24" x 36" and 6" x 36", Per inch of thickness—	3.5	
85% Magnesia Blocks.....	3" x 18" and 6" x 36", Per inch of thickness—	1.4	
Vitribestos Sheets .....	36" x 72" .....	1/2"	.88
	36" x 72" .....	3/4"	1.3
	36" x 72" .....	1"	1.8
	36" x 72" .....	1 1/4"	2.2
	36" x 72" .....	1 1/2"	2.6
	36" x 72" .....	2"	3.5
	36" x 72" .....	2 1/2"	4.4
	36" x 72" .....	3"	5.3
Fire-Felt Sheets and Blocks.....	24" x 36" and 6" x 36" .....	1/2"	1.2
	24" x 36" and 6" x 36" .....	3/4"	1.8
	24" x 36" and 6" x 36" .....	1"	2.3
	24" x 36" and 6" x 36" .....	1 1/4"	2.9
	24" x 36" and 6" x 36" .....	1 1/2"	3.5
	24" x 36" and 6" x 36" .....	2"	4.4
	24" x 36" and 6" x 36" .....	2 1/2"	6.2
	24" x 36" and 6" x 36" .....	3"	7.0
Thermo Fire-Felt Sheets.....	24" x 36" .....	1 1/2"	3.5
	24" x 36" .....	2"	4.5
Vitro Fire-Felt Sheets.....	24" x 36" .....	1 1/2"	3.8
	24" x 36" .....	2"	4.8
Improved Asbestocel Sheets and Blocks	4-Ply to the inch.....	36" x 36", 3" x 18", 4" x 18", 6" x 36", 1"	1.0
	6-Ply to the inch.....	36" x 36", 3" x 18", 4" x 18", 6" x 36", 1"	1.3
Asbestocel-Flexible Roll Form.....	36" wide in rolls of about 250 sq. ft	1-ply	.25
Asbestos Roll Fire-Felt.....	36" " " " " " 100 " 3/8"		.38
	36" " " " " " 100 " 1/2"		.59
	36" " " " " " 100 " 5/8"		.75
	36" " " " " " 100 " 3/4"		1.2
	36" " " " " " 100 " 7/8"		1.5

### List Prices

*Asbesto-Sponge Felted, 85% Magnesia, Vitribestos, Improved Asbestocel, Fire-Felt, Thermo Fire-Felt and Vitro Fire-Felt*

Thickness Inches	Price per Sq. Ft.	Thickness Inches	Price per Sq. Ft.	Thickness Inches	Price per Sq. Ft.	Thickness Inches	Price per Sq. Ft.
1/2"	\$.27	1 3/8"	.42	2 1/8"	\$.64	2 7/8"	.87
3/4"	.27	1 1/2"	.45	2 1/4"	.68	3"	.90
7/8"	.30	1 5/8"	.49	2 3/8"	.72	3 1/4"	.98
1"	.30	1 3/4"	.53	2 1/2"	.75	3 1/2"	1.05
1 1/8"	.34	1 7/8"	.57	2 5/8"	.79	4"	1.20
1 1/4"	.38	2"	.60	2 3/4"	.83		



## Johns-Manville Insulating Cements

**J**OHNS - MANVILLE Insulating Cements are composed of asbestos and binding materials that are low conductors of heat or efficient insulators. They are applied, when mixed with water, in plastic form, producing an efficient insulation when dry.

They are generally used as a surface finish over block or sheet forms of insulation

to seal all joints between the blocks and to provide a smooth, attractive finish or a surface to which canvas may be applied if desired.

Johns-Manville Insulating Cements are also especially adapted for insulating irregular surfaces where it would be impracticable to apply sectional insulation, sheets or blocks.

### Johns-Manville Asbestos Fire-Felt Insulating Cement No. 302

Johns-Manville Asbestos Insulating Cement No. 302 is made of asbestos fibre and binding materials that have high insulating values. It is easy to mix and apply, and readily adheres to hot surfaces. As it is light in weight and high in insulating value, No. 302 is one of the most economi-

cal insulating cements manufactured.

Johns-Manville Asbestos Insulating Cement No. 302 finishes with a hard, durable and attractive surface, and does not peel, crack or break off.

Packed in 100 pound bags.

### Johns-Manville Asbestos Insulating Cement No. 400

Johns-Manville Asbestos Insulating Cement No. 400 is a combination of asbestos and other materials of high insulating value. It is an ideal insulating cement for

general use where efficiency, strength and durability are desired. Besides its high insulating efficiency, it provides a smooth, durable finish. Packed in 100-pound bags.

### Other Johns-Manville Insulating Cements

Johns-Manville manufactures and is prepared to furnish 85% Magnesia Insulating Cement, also Johns-Manville No. 364 and No. 352 Cements. The latter two

cements are not as high in insulating value as those referred to above and are generally used where a less expensive material is required.

**NOTE:**—The efficiencies of insulating cements cannot be given in definite figures because the efficiency of a given cement may vary greatly according to the manner of application, the form of the surface on which it is applied, etc. However, it may be said that for the better grades of insulating cements applied one inch thick on flat surfaces and at temperatures corresponding to average high pressure steam conditions (about 150 lbs.), the efficiencies vary approximately from 70% to 85%.

# Johns-Manville Refractories and Cement Specialties

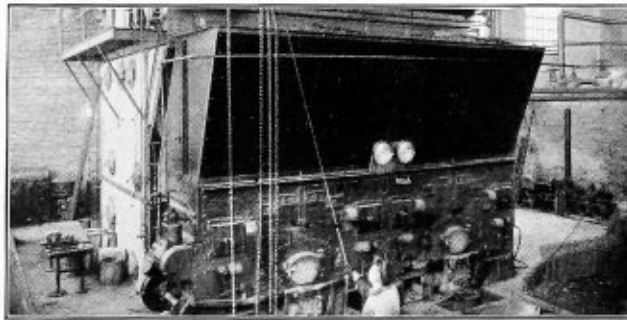



## Johns-Manville Refractory Cements

**O**UR object in discussing refractories at length is two-fold—to effect an economy for you by briefly pointing out why boiler and furnace settings do not always last as long as they should, and to give information relative to Johns-Manville Refractory Cements, which materially increase the life of boiler and furnace settings, thereby providing greater economy and return on the money invested in this important part of power equipment.

The purpose of furnace settings is to provide a chamber for the most efficient combustion of the fuel used, which will in the best manner possible direct the heat to the absorbing surfaces without waste and without the intermingling of excess air. Naturally the most economical results are obtained when these settings stand up without impaired efficiency, under the conditions incidental to their service, for the longest possible time.

While oil burners, mechanical stokers, and mechanical draft all contribute to increase power plant efficiency, they result in more severe furnace conditions and more frequent failures in furnace settings unless careful thought is given to the subject and the correct precautions taken.

The failure of a furnace setting is not necessarily indicative of faulty brick. Failures are often due to the inability of the fire clay or bonding cement used, to fulfill its function.

The best furnace setting has the proper design, is constructed by careful and experienced workmen, and is made of the best fire brick for the conditions, bonded

together and protected with a high grade refractory cement.

### Why Firebrick Settings Fail

Excluding the human element of workmanship, failures can generally be traced to one or more of the following causes:

Plastic deformation, melting, spawling, cracking or bulging, slagging, or clinkering.

### Plastic Deformation

Plastic deformation will occur when a load is applied to brick that has softened or reached the stage of incipient fusion because of high temperature.

If only one face or surface of a brick is exposed to the heat, the temperature may be increased to a point far beyond what the brick would stand if the entire brick were surrounded by heat or if even small portions of the other five surfaces were exposed. The reason is that when only one face or surface is exposed, the brick conducts the heat from that surface only.

Exposure of the four adjacent surfaces of the brick to the fire occurs in a furnace setting in which the fire clay or inferior cement bond between the brick has given way. This results from the melting out of the bond on account of its inability to resist the heat, or from the crumbling and falling away of the bond due to its failure to withstand expansion and contraction.

When Johns-Manville Refractory Cement (No. 26, 31 or 33, depending upon the temperature) is used as a bond, the flame can attack the brick on one face





only. These cements will withstand temperatures of 2600, 3100 and 3300 degrees F., respectively, without melting, and will not disintegrate and fall out of the joints when the brickwork is under stress.

## Melting

Ordinarily the fusion point of a fire brick would appear to be its most important characteristic, but in most cases failures will occur from plastic deformation before fusion occurs.

The same precautions as taken in the case of plastic deformation will help materially to resist melting of fire brick.

## Spawling

Spawling is the breaking off of pieces of brick or cracking due to an effort of the different parts of the brick to assume different volumes—which is impossible for a hard mass like a fire brick without internal strains. When expansion or contraction occurs quickly, as when boiler doors are opened and cold air allowed to rush in; or within a short temperature range, in the case of bricks with a high co-efficient of expansion or contraction; if the change in volume is considerable; or the temperature unevenly distributed, causing uneven expansion or contraction in the brick, then failure by spawling is likely to occur. If more than one surface of the brick is exposed to the heat, especially portions of the four adjacent sides, that part of the brick which is so exposed becomes hotter than the balance of the brick and this causes internal stresses which result in spawling. Bricks bonded with Johns-Manville Refractory Cement have well protected joints and do not take on or give up heat as quickly as bricks with exposed sides, so the temperature range of expan-

sion and contraction is increased. Besides, as the heat enters the brick from one face only, the temperature gradient is even and there is less probability of internal stress.

If spawling, plastic deformation, or melting takes place even though the bricks are bonded together with Johns-Manville Refractory Cement, which may happen

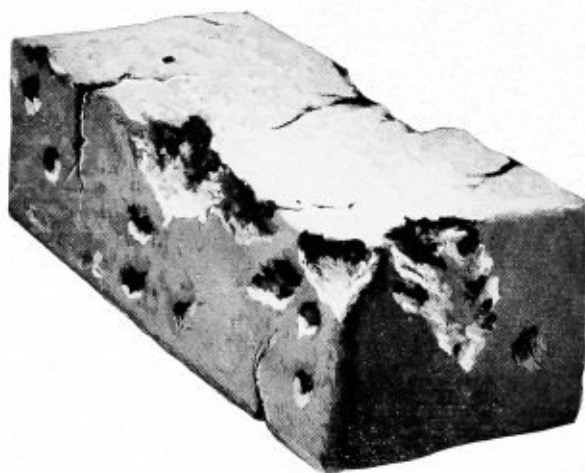

This illustration shows how severe heat attacks and destroys fire brick when it is not properly protected by carefully chosen refractories. Surface cracking and spawling and the expense of consequent shut downs and replacements, can be reduced by bonding and wash-coating fire brick with Johns-Manville refractories.

under exceptionally severe conditions, additional protection can be had by applying a  $\frac{1}{4}$ " to  $\frac{1}{2}$ " thick coating of Johns-Manville No. 33 Super-Refractory Cement to the surface of the combustion chamber. This coating protects the fire brick from sudden changes in temperature and protects the brick from the radiant heat of combustion.

## Cracking and Bulging

Expansion and contraction of fire brick will cause a setting to crack or bulge. When fire clay is used for setting up the brick, attempts are often made to overcome its inability to stay in the joints by reducing



the thickness of bond. This method throws all the stress due to expansion and contraction on the brick itself and causes more severe cracking or bulging. Johns-Manville Refractory Cements not only decrease the amount of expansion and contraction because of the protection they give, but also have the necessary amount of elasticity to cushion the strain resulting from expansion and contraction.

### Slagging

The erosive action or slagging of fire brick by molten ash is very prevalent where coals are used having an ash which softens at a comparatively low temperature. The flames carry particles of molten ash which enter the cracks or pores in the fire brick setting. This combination of ash and fire brick has a lower melting point than the fire brick itself. The deeper the molten ash enters the fire brick, the more severe will be the action. If the joints of a setting are well protected with Johns-Manville Refractory Cement as a bond, and the pores and minor cracks in the fire brick filled with a wash coating of Johns-Manville No. 32 Refractory Cement, slagging is less likely to occur.

### Clinkering

It is practically impossible to prevent clinkering, but it can be retarded if the setting is made as smooth as possible. This can be accomplished in a furnace setting by using Johns-Manville Refractory Cement as a bond and then wash-coating the entire setting with Johns-Manville No. 32 Refractory Cement. This eliminates cracks and crevices which permit the building up of the clinker mass. The greatest trouble occurs in removing the clinker. Unless fire brick are strongly bonded together, which is not the case

when fire clay is used, bricks are liable to be pulled out with the clinkers when the latter are removed with the slice bar.

One refractory cement cannot be a panacea for all ills. Conditions are so varied and the requirements of a refractory so diversified that it is necessary to have different cements with different properties.

Guess work or haphazard treatment of refractory cement problems will mean early failure and expense that could be avoided. Realize the importance of using the correct material in the correct manner and call on Johns-Manville who have trained engineers available for this service.

### Johns-Manville Refractory Cement No. 26

Recommended for setting up fire bricks of boilers and furnaces. It may be used where temperatures range from 900° F., where vitrification begins, to 2600° F., the highest temperature it will withstand.

No. 26 has exceptional strength and bonding qualities. It is the proper cement to use for all general conditions except where temperatures exceed 2600° F., (where because of temperature, a refractory cement having a higher melting point should be used) or where special chemical or metallurgical conditions are to be met. For the latter case consult Johns-Manville engineers. No. 26 Cement is packed in 100 lb. paper-lined bags and 400 lb. barrels.

### Johns-Manville Refractory Cement No. 31

When temperatures exceed 2600° F., and for this reason, No. 26 cannot be used, the proper cement for all general conditions is Johns-Manville Refractory Cement No. 31. This cement can be used for



temperatures up to 3100° F., its highest working temperature. It may also be used for temperatures ranging from 1450° F., where vitrification begins, to 2600° F., but it is preferable to use No. 26 for this temperature range. When special chemical and metallurgical conditions are to be met, consult Johns-Manville engineers. No. 31 Cement is packed in 100 lb. paper-lined bags and 400 lb. barrels.

### Johns-Manville Refractory Cement No. 32

Made for wash coating the face of brickwork exposed to flame and heat. It will withstand any temperature from 1250° F., where vitrification begins, to 3100° F., its highest working temperature. No. 32 is packed in 100 lb. paper-lined bags and 400 lb. barrels.

### Johns-Manville Super-Refractory Cements Nos. 33 and 35

These super-refractory cements have been developed to meet the exceptionally severe conditions resulting from improved methods of fuel burning, melting of metals, etc. The extremely high temperatures which are daily encountered in special process work and even in the fire boxes of oil-burning boilers, have made necessary a super-refractory cement.

The exceptional and important quality of these super-cements is their ability to withstand high temperatures with a comparatively small amount of shrinkage. The possibility of cracking under severe temperatures is thus reduced to the minimum. Because of the character of these materials, there is little chance of chemical reaction and they will not be affected by molten yellow metals such as brass, bronze, etc. For use in connection with

electrical and special furnaces, these cements have been found especially well adapted.

No. 33 should be used where temperatures range from 1000° F., where vitrification begins, to 3300° F., the highest temperature it will withstand.

No. 35 should be used where temperatures range from 1200° F., where vitrification begins, to 3500° F., the highest temperature it will withstand.

Super-Refractory Cements Nos. 33 and 35 are packed in 100 lb. paper-lined bags.

### Johns-Manville Refractory Cement No. 30

No. 30 is especially recommended for general iron and steel metallurgical conditions such as blast furnaces, cupolas, reheating furnaces, one-piece linings for crucible furnaces, etc. It begins to vitrify at 1850° F. and is resistant to temperatures up to 3000° F. Being a carbon base cement it will give best service in a reducing atmosphere.

No. 30 Cement is packed in 100 lb. paper-lined bags and 400 lb. barrels.

### Directions for applying Johns-Manville Refractory Cements Nos. 26, 30, 31, 32, 33 and 35

When preparing Johns-Manville Refractory Cements Nos. 26, 30, 31, 33, and 35 for use as a bond between fire bricks, mix the water with the cement to get the proper consistency. The amount of water required can best be found by trial. When setting brick, it depends upon the porosity of the brick. Porous brick will require a thinner mixture than those less porous.





The mortar should be thoroughly mixed and free from lumps. A batch of refractory cement mortar, may have a good appearance, and yet, if a few handfuls of the batch were taken and rubbed together, some cement might be found that was dry—not mixed with water.

It is just as important that an excess of water be avoided. Depend on thorough mixing to obtain the proper consistency rather than too much water.

“Butter” or trowel the cement on the brick already placed, then lay brick on top and tap until the joint between the bricks is about three-sixteenths inches thick and cement squeezes out between the edges of the brick.

Do not “point up” or cut off cement that squeezes out between the edges, but plaster or trowel it back over the face of the

joint and brick, so that it protects the edges of the brick. In other words make a “T” joint. (See illustration.)

When using Johns-Manville No. 32 or No. 33 Refractory Cement for wash coating, the cement should be thoroughly mixed with sufficient water to bring it to a thin grout consistency and then applied to the face of the brick work with a stiff brush or broom.

In treating a fire box with a plastic coating of Johns-Manville No. 33 Super-Refractory Cement to resist spawling, plastic deformation, and melting, all clinkers and loose pieces must first be removed, any particularly smooth or glazed surfaces chipped away, and keys cut into the wall to a depth of at least  $\frac{1}{2}$ " at practically every course of brick. Then No. 33 should be applied by means of a trowel in the

## Cross-sections of Fire Brick Joints



Fire Clay joint before firing.



After firing. Fire Clay joint open, allowing heat to attack front surface and portions of sides of brick.

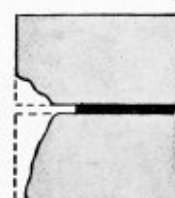

After more heat. Bricks starting to spawl.



Johns - Manville Refractory Cement as mortar on the brick already placed.



Upper brick placed and tapped down until Johns-Manville Refractory Cement has squeezed out at edge of joint.



Finished "T" joint of Johns-Manville Refractory Cement. After firing and vitrifying, the bonding material forms a strong protection for the joint.

Showing that when Johns-Manville Refractory Cement is used for setting up the brick, the edges of the brick are protected against the action of the flames.

It will be noted in the illustration that the Johns-Manville Refractory Cement joint is shown thicker than the customary fire clay joint. This is because it has been found that a three-sixteenth inch bond of Johns-Manville Refractory Cement gives the best results because the greatest strength is secured with this thickness and the desired elasticity to withstand expansion and contraction of the fire bricks is obtained. The fact that a Johns-Manville Refractory Cement bond will not disintegrate, crack, and fall away under heat, which is the case with fire clay joints, makes it possible to use this thickness of joint.





form of a plaster coating at a dense mortar consistency. The coating should run from  $\frac{1}{4}$ " to  $\frac{1}{2}$ " in thickness, depending upon the severity of the conditions.

*Always make sure that the cement and water are thoroughly mixed.*

When No. 26 is to be used for molding dampers, slabs, door-linings, etc., mix the cement with sufficient water, but not too much, until the mixture has a consistency of dry molding sand, and is absolutely and thoroughly mixed and free from lumps.

Tamp cement in mold, or in place, solidly and then dry gradually with a slow fire till all water has evaporated. After all water has been slowly driven out, the slab or molded piece may be subjected to temperatures in excess of 900 degrees F., which will vitrify it.

Large molded pieces should be reinforced by surrounding the edges with an iron band or frame and by running iron bolts or rods through the slab. All such rods should be covered or wrapped with asbestos paper to a thickness of about one-sixteenth inch. This allows for the expansion of the iron.

## Johns-Manville Plastic Refractory Cement No. 29

Plastic Refractory Cement No. 29 is primarily a patching cement. It can be used for either hot or cold patching in boiler or furnace settings, gas plant and by-product coke plant equipment, etc., within the temperature range of 1200° to 2900° F.

When patching work is done, loose pieces should be removed, all glaze scraped away, and the part to be patched thoroughly cleaned.

Plastic Refractory Cement No. 29

comes in a dense, plastic state ready for use and is packed in 100, 250, 450, and 800 lb. drums.

## Johns-Manville Plastic Refractory Cement PR-15

PR-15 may be used for temperatures up to 2600° F., its highest working temperature. This cement is furnished in plastic form and sets hard when air dried.

It can be used as a mortar in setting up bricks and patching in furnace settings, ovens, kilns, gas plant and coke plant equipment, etc., when temperatures are not high enough to vitrify other Johns-Manville Refractory Cements. Also for setting up bricks, where a ready-mixed plastic refractory is absolutely demanded, when temperature is less than 2600° F.

PR-15 is packed in 10, 25, 50, 100, 250, 450 and 800 lb. containers.

NOTE:—Wherever possible it is preferable to use a dry, machine mixed, refractory cement rather than a plastic cement for bonding and wash-coating fire brick, not only from a standpoint of economy, but also because of greater satisfaction in the results obtained.

## Johns-Manville Retort Cement No. 20

No. 20 Retort Cement may be used as a refractory in connection with temperatures up to 2000° F. This cement is furnished in plastic form and sets hard when air dried.

It is admirably adapted for general use around gas works and chemical plants wherever a cement is required that must resist acid fumes as well as heat.



On account of its combined refractory and acid fume-resisting qualities it is recommended for setting up brick smoke stacks. It may also be used for setting up fire brick when temperatures are not sufficient to vitrify other Johns-Manville Refractory Cements.

No. 20 Retort Cement is packed in 1, 5, 10, 25, 50, 100, 200, 450 and 800 lb. containers.

## Directions for applying Johns-Manville PR-15 and No. 20 Retort Cement

These cements are furnished in ready mixed form and can be used directly from the container. If they require thinning, add water gradually, mixing thoroughly as the water is added.

If only a portion of the contents is used and it is desired to hold over the balance for another job, cover the cement with a wet cloth or a thin seal of water. Replace cover to exclude air as much as possible and store in a cool place.

## Special Refractory Cements

We manufacture and are prepared to furnish special refractory cements for conditions to which our standard cements are not adapted, such as conditions where chemical reaction, molten metal or gases prevent the use of our standard refractories, and in general, conditions that require a careful study of service for which the refractory is to be used before a definite recommendation can be made. Engineers are available at all Branches.

TECHNICAL DATA—VARIOUS QUALITIES OF REFRACTORY CEMENTS

	No. 20 Retort	PR-15	No. 26	No. 30	No. 31	No. 32	No. 33	No. 35	Johns- Manville Baffle Wall Cement
Lowest working temperature or low point of vitrification (° F.)	900*	800*	900	1850	1450	1250	1000	1200	1000
Highest working temperature (° F.)	2000	2600	2600	3000	3100	3100	3300	3500	2900
Melting point (° F.)	2250	2700	2700	3050	3182	3146	3350	3542	3000
Complete fusion, dry powder (° F.)	2250	2750	2750	3100	3254	3200	3362	3570	3050
Specific Gravity	1.84	2.06	1.68	1.85	1.76	1.77	1.65	1.6	1.99
Weight in lbs. per cu. ft., dry moulded	.....	.....	105	116	110	.....	121	121	.....
Weight in lbs. per cu. ft., powdered	.....	.....	77	78	99	80.1	103	100	.....
Approximate capacity: lbs. required for setting 1,000 brick, with $\frac{3}{16}$ inch thickness of joints	400-550	450-600	500-650	660-850	550-700	.....	670-850	670-850	.....
**Approximate capacity: lbs. required per hundred sq. ft. to coat the surface of fire brick settings $\frac{3}{16}$ inch thick	.....	.....	.....	.....	.....	90	.....	.....	.....
Character	Acid	Acid	Semi-Acid	Neutral	Semi-Acid	Semi-Acid	Semi-Acid	Neutral	Semi-Acid
Linear shrinkage at 2250° F (per cent. of length of dry sample before heating)	3.3***	2.0***	1.5	1.4	2.0	4.5	1.0	0.0	0.0
Free and combined silica content (per cent.)	.....	.....	46.77	13.9	55.11	52.5	50.0	9.5	41.6
Free and combined carbon content (per cent.)	.....	.....	0.0	74.4	0.0	0.01	0.0	0.0	0.0

\*Sets hard when air-dried.  
 \*\* Quantity of No. 32 cement required for coating varies a great deal, depending upon the porosity of the brick. Based on average conditions and when the cement and water are used in equal quantities, i.e., 100 pounds cement and 100 pounds water, 90 pounds of cement are required per 100 square feet of surface.  
 \*\*\* Shrinkage on air drying.



## Johns-Manville Monolithic Baffle Walls

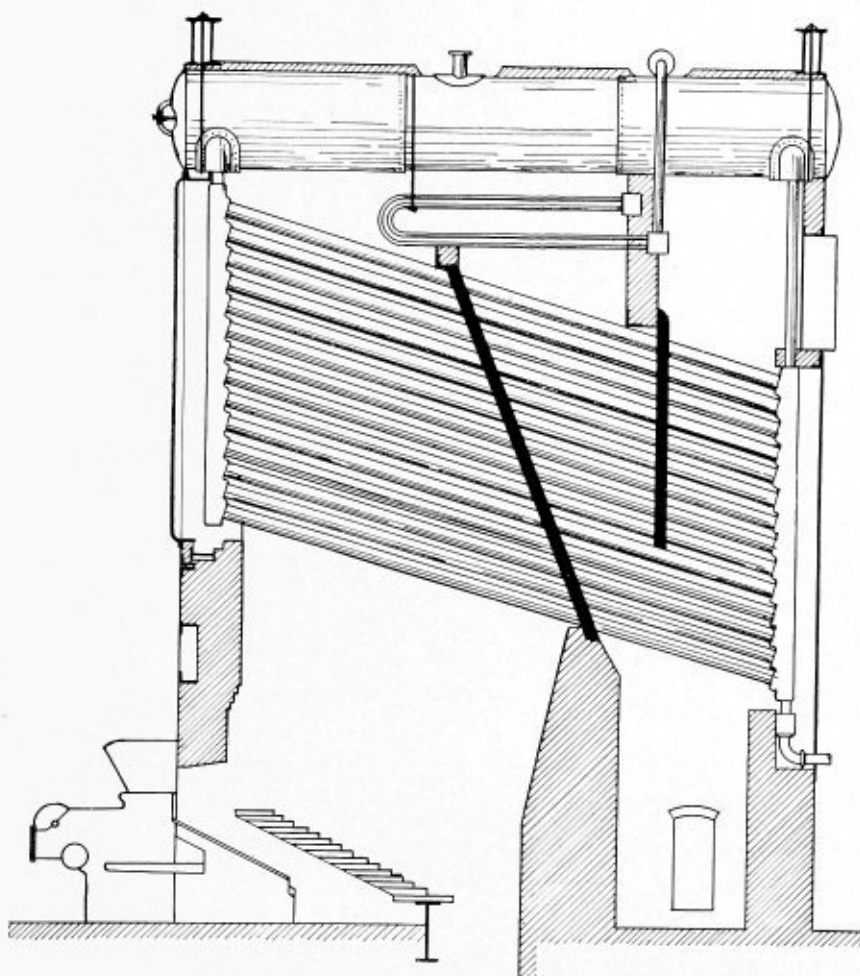

How Johns-Manville Monolithic Baffle Walls effectively direct the flow of the gases of combustion and eliminate "short circuiting" and heat losses.

Baffle walls are built to prevent hot air and gases from taking the shortest cut from the fire to the smoke connection of the boiler. They deflect hot gases to a roundabout route that brings the gases in contact with all of the tubes and heating surface of the boiler, and so the maximum amount of heat is transferred from the hot gases to the water in the boiler and the minimum heat is lost up the smoke stack.

Furthermore, better and more complete combustion is obtained and more heat

units from the fuel utilized by directing the course of hot gases.

Ordinary baffles are built of many pieces of tile formed to fit and placed around the tubes, and it is not only a tedious task to install them but their life is limited. Moreover, of greater importance, there is leakage through the cracks or spaces between the pieces of tile, and gases that leak through these cracks are not giving up all the heat they should.

It is most important that the front baffle



This is an excellent illustration of the Johns-Manville Monolithic Baffle Wall, showing as it does, a solid wall built up around the tubes, with none of the joints and cracks necessarily found in tile baffle walls. It can readily be seen from this picture that leakage of heat-laden gases through such a wall is absolutely impossible, as it is built of a material that will resist and withstand highest temperatures encountered without melting or cracking

be tight, for gases at this point contain the maximum number of heat units, and the difference between the temperatures of the gases and hot-water tubes is greater than in any other part of the boiler.

The Johns-Manville Monolithic Refractory Baffle is moulded of Johns-Manville Baffle Wall Cement. It is poured between wooden forms and makes a solid heat-resisting wall 4 to 5 inches thick, durable, far more efficient and hence much superior to tile baffles which are generally used.

The principal advantages of the Johns-Manville Monolithic Baffle are:

1. A monolithic wall built of material that will resist and withstand highest temperatures encountered without burning, melting or cracking.

2. A monolithic wall with no joints or cracks to allow hot gases to short-cut to the stack without giving up the maximum number of their heat units.

3. A monolithic wall comparatively easy to install, as it is much easier to erect wood forms, mix and pour the cement than to install a great number of small pieces of tile.

4. A monolithic wall that is durable and requires little or no attention for a long time after installation.

5. A monolithic wall through which tubes may be withdrawn and replaced if necessary *without damage to the baffle*.

6. A monolithic wall that may be installed at any desired angle with the tubes.





## Johns-Manville Aertite Boiler Wall Coating

**A** TOUGH, rubbery coating in plastic form used for covering the outside of boiler walls to prevent the infiltration of cold air into the combustion chamber.

Cracks and crevices in boiler wall settings mean lower efficiency and higher operating costs. While many cracks are quite small they will allow sufficient leakage to lower immediately the boiler efficiency. Cold air that leaks in absorbs heat until it reaches the temperature of the furnace gases and hence wastes heat that would otherwise perform useful work. It is conservative to estimate on the following basis — if air leakage through boiler walls amounts to only 5% of the actual quantity of air required for proper combustion and high efficiency—1% of the fuel burned is wasted. However, leakage often amounts to far more than 50% and, figured on the above basis, the fuel wastage is correspondingly greater.

Sheet or block insulation properly applied to boiler walls is of course the most satisfactory manner of preventing infiltration of air through the boiler walls, and the radiation of heat from their surfaces. However, if such insulation is not applied the infiltration of

air can be eliminated at a comparatively small expense by the application of Johns-Manville Aertite Boiler Wall Coating.

It forms a tough, rubbery coating or blanket over the entire boiler wall setting which remains tight on account of its adhesive and ductile qualities. It is easily applied with a trowel.

Best results are obtained by keeping the thickness as near  $\frac{1}{16}$ " as

possible. Amount required for  $\frac{1}{16}$ " thickness—25 to 40 lbs. per 100 square feet, depending upon the number and variety of cracks and the way the wall has been pointed up.

Furnished in 25, 50, 150, 300 and 500 lb. containers. Prices on application.

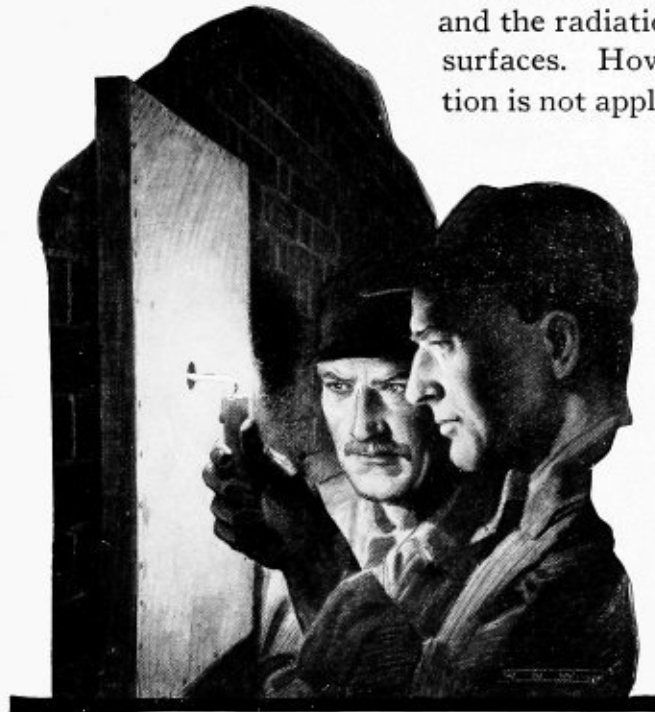

### HOW TO TEST A BOILER WALL

Fasten a square of cardboard having a small aperture at its center over a wooden frame. By pressing this frame against a boiler wall with the edges temporarily but completely sealed by some plastic material, any leakage in this part of the boiler wall will immediately be detected by the inrush of air at the small aperture. A candle flame held to this aperture will be sucked inward if there is an infiltration of air through the boiler wall. By this method, an entire boiler wall can be very quickly tested.



### Johns-Manville Leak-No Metallic Compound

**A** CHEMICAL metallic compound for repairing and closing holes and leaks in iron or steel, prepared in powdered form and used by mixing with water to a stiff putty. It metallizes in a few hours and becomes a part of and the same color as the casting to which it is applied.

Johns-Manville Leak-No differs from all other compounds made for similar purposes in that it does not adhere as a cement, but amalgamates with the metal itself and makes a permanent repair. It will hold high pressures, will not flake off, and will resist any heat, acid, gas, or oil that iron will stand.

### Johns-Manville Ferrotite Cement

A liquid for stopping up sand holes and spongy spots in castings. Ferrotite is poured into the cavity and after two or

three hours is poured out, and the casting allowed to stand two or three hours before using. Excess material can be used again.

### Johns-Manville H-O Pipe Joint Cement

A powdered material which may be mixed with linseed oil and used for making tight joints for all pipe work, such as steam, gas, water and air.

Economical, non-poisonous, stainless, does not cause a bad taste in water, and

makes a tight and permanent joint.

By mixing with water it can be used as a putty for connecting sink wastes, basement plugs, bowls, bath plugs, etc.

Also furnished ready mixed with linseed oil.

### Johns-Manville Fireite Asbestos Furnace Cement

A strong and durable cement for setting up and repairing broken joints in furnaces, ranges, heaters and stoves. It is prepared ready for use, adheres readily and firmly to castings and sheet metal and "sets" in

a few hours after application. When subjected to heat it vitrifies without shrinking or becoming porous. It is inodorous, and effectually prevents escape of smoke, gases and dust, thus insuring perfect draft.

### Johns-Manville Phoenix Asbestos Stove Lining

This is a perfect substitute for, and a great improvement upon, the old style of stove-brick for making new linings and repairing cooking stoves, ranges, heaters, etc., also for lining doors of boilers and furnaces.

It costs less than stove-brick, is always

ready for use, will conform to irregular surfaces, can be easily applied, does not easily burn out and clinkers do not tend to adhere to it. Much time, and often serious injury to the stove, may be saved by having Johns-Manville Phoenix Lining on hand and not being compelled to send to distant points for stove-brick.

# Johns-Manville Packings

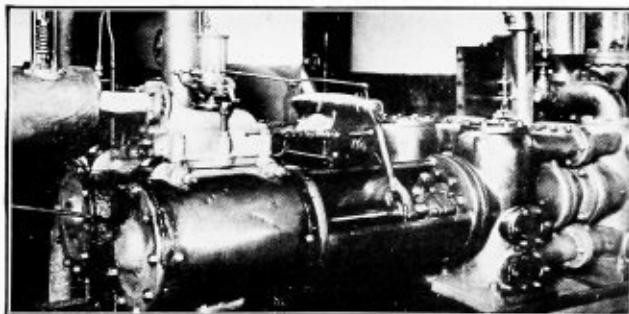



## Johns-Manville Sea Rings



Note particularly the flexible lip and hollow space back of it which make the action of Sea Rings automatic.

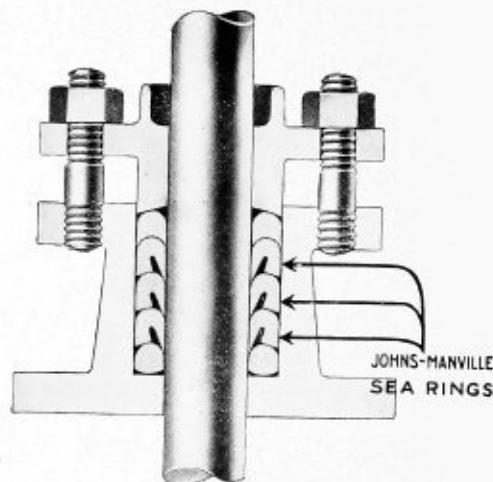

Cross-section of stuffing box showing Sea Rings in place.

**F**OR packing rods and outside packed plungers against steam, water, air, brine and any other fluid that will not attack the materials used in their construction. Furnished in ring form only.

Johns-Manville Sea Rings are made for rods or plungers  $\frac{3}{4}$ " in diameter or over, providing flange or space between rod and stuffing-box is  $\frac{3}{8}$ " or more. The action of Sea Rings is absolutely automatic. They press against or grip the rod only when there is a tendency to leakage through the stuffing-box. The pressure through the box acts on the lips of the packing and in proportion to the pressure.

The elimination of unnecessary friction where Sea Rings are used means great economy, on account of the saving in power required to drive the apparatus. The data and curves shown on page 61 conclusively prove the economy of Sea Rings even when good packing of the ordinary type may be purchased for less.

Long life and service are obtained from Sea Ring Packing, because, by preventing unnecessary pressure and friction between rod and packing, needless wear is eliminated.

Leakage is prevented because the flexible lip more readily conforms to rod or plunger than the inside surface of an ordinary solid packing.

Loss of time and expense due to shut-downs and labor cost of renewals are reduced to the minimum, because of the durability of Sea Rings.

Sea Rings assist in Packing Standardization through the elimination of a number of packings for various conditions, because they are constructed of materials that make them the best packing obtainable for nearly all conditions encountered where rod and plunger packing is required.







B—It costs \$115.00 to pack same pump with Sea Rings for one year. (Sea Ring packing will last longer. See Note B, below.)

It costs \$551.12 to drive pump with electricity, one year, same number of hours as above. (7.36 K.W. per hour=55,111.6 K.W. hours at 1c per K.W. hour.)

Saving in cost of power to drive pump packed with Sea Rings for 1 year..\$167.73

Premium paid for Sea Ring Packing (difference between cost of Sea Rings and Flax, \$115.00—\$40.00).. 75.00

Actual net saving first year accomplished by the use of Sea Ring Packing ..... \$92.73

This is a return of more than 123% on the \$75.00 premium paid for Sea Rings.

Note A—Two packings of flax a year is conservative as pump was actually packed with flax every 4 months.

Note B—These Sea Rings were in service from November, 1917, to November, 1922.

As Sea Rings lasted five years—the last four years they saved—

Eight packings of flax at \$20.00 each..\$160.00

67,092 kilowatt hours at 1c each..... 670.92

Total additional net saving in four years ..... 830.92

Net saving first year was..... 92.73

Total net saving for five years is.... 923.65

Also note that actual cost of Sea Rings (\$115.00) is less than the cost of 10 flax packings at \$20.00 each, or \$200.00

Do not overlook the fact that electrical current saved per year was 16,773 K.W. hours.

This means that the pump packed with flax consumed 30.4% more current than when packed with Sea Rings.

## Sea Ring Service

**I**T costs more to pack a stuffing-box with Sea Rings than with any other packing—except some types of mechanical (metallic) packing.

But the service rendered by Sea Rings makes them the most economical packing to purchase and use.

This service is due to their automatic action which reduces friction to the minimum, and so reduces wear on the packing and power required to drive the rod back and forth through the packing.

Either service alone—that of long life or that of power saving—will effect sufficient saving to justify the purchase of Sea

Rings. Combined, the saving afforded by Sea Rings amounts to a large return on the investment.

The life of Sea Rings depends upon the service to which they are subjected, and in drawing conclusions from test data their life should be compared to the life of other packings used under identical conditions.

The saving of power by Sea Rings is indisputable, and easily determined and checked by measuring the power required to drive a machine before and after it is packed with Sea Rings.

See chart and data on this and the preceding page.

### *Some examples of service rendered by Johns-Manville Sea Rings*

#### *Hot Water Service*

Outside packed boiler feed pump at American Steel and Wire Consolidated Works, Cleveland:

Plungers 12" in diameter, pumping hot water at a temperature of from 210 degrees to 212 degrees against a boiler pressure of 175 pounds.

Two sets of Sea Rings were in service on the above pump for five years.

#### *Air Compressor Service*

A set of Sea Rings was installed at the foundry of a large electric company in January 1919 on the high pressure rod of an Ingersoll-Rand Compressor. This compressor operates at 257

R.P.M., the greater part of the time for 24 hours a day and 6 days a week, and develops 100 lbs. pressure. These Sea Rings were replaced by new ones on March 26th, 1922, having required practically no attention during their lifetime.

#### *Centrifugal Pump Service*

Sea Rings used on a Wilson-Snyder centrifugal pump operating under varying speeds, from 750 to 1350 R.P.M., at one of the plants of a large steel company have lasted nine months and over where formerly the ordinary packing used was replaced weekly, and a brass sleeve, used in the stuffing-box, replaced every two weeks.



## Directions for the installation of Johns-Manville Sea Rings

**A** SET of Johns-Manville Sea Rings is usually composed of one header ring, several Sea Rings and one follower ring. (See tags attached to rings.) The number of Sea Rings used depends upon the depth of the stuffing box.

1. Remove old packing and clean stuffing box.
2. Install first header, so tagged, and as arranged in set when received, so first Sea Ring will fit properly against it. See that it is pushed back so all of it is seated against bottom of box.
3. Install Sea Rings with lips toward pressure, or back of box, joint of each ring to be on opposite side of box from joint of preceding ring.
4. Do not pull ends of rings straight apart, but separate them sidewise to pass over rod.
5. Work two ends of rings into box first, then remainder of ring.
6. See that each ring is completely seated before installing next ring.
7. Never cut off ends or any part of rings, which are made to fit tight against inside of box.
8. After all Sea Rings are in, install last follower ring, so tagged, and as arranged in set when received, so as to fit properly against last Sea Ring.
9. *Excessive* gland pressure on Sea Rings will tend to distort the shape of the rings and reduce their efficiency and life, but it is also just as important that the gland presses against the packing with sufficient force to prevent movement of the packing in the stuffing box.
10. Packing gland nuts should be frequently inspected and always kept tight enough to prevent any movement of the Sea Rings. Such motion will cause wear on the outside of the ring, possibly twisting or cocking of the ring in the stuffing box, and eventually a failure.
11. After Sea Rings have been in service their size or volume may be reduced to some extent on account of wear, and if such is the case this necessitates taking up the gland.

## Specifications

*(For those who desire to specify by description)*

Each set of packing shall have inside, outside and depth dimensions suitable for the rod and stuffing box for which it is intended, and is to consist of several packing rings and not less than one or more than two auxiliary rings or headers.

The packing rings of each set shall be constructed of a suitable fabric and friction or rubber cement for binding the plies of fabric together, and each ring shall have a "U" formed section having a thick heel on one side and a tapering, flexible lip or tongue on the other side.

The thick heel shall be harder than the lip, which shall be flexible so as to conform to the surface of the rod or plunger which it packs.

The end of the heel shall be beveled or molded so that it makes an angle of approximately 75

degrees with the axis of the rod or plunger packed.

The design and construction of the packing must be such that its action is positive—that is, the pressure of the packing on the rod or plunger must be dependent upon the pressure through the packing or stuffing-box and not dependent upon the pressure of the gland on the packing.

The auxiliary or header rings shall be of such construction and shape as to provide suitable seats for the first and last packing ring in the box to rest against.

The above described packing is not to be furnished where the space between the rod or plunger and the inside of the stuffing-box is less than  $\frac{3}{8}$  of an inch or where the diameter of rod or plunger is less than  $\frac{3}{4}$  of an inch.





# Johns-Manville Kearsarge Rod Packing



Spiral Style No. 166



Ring Style No. 150

**F**OR packing rods where space between rod and inside of stuffing box is  $\frac{3}{8}$ " or over.

The asbestos and other materials used and the construction of Kearsarge Rod Packing make it suitable for steam or air at any temperature and pressure, which eliminates the necessity of using several packings for various steam and air conditions. This means a minimum stock and the convenience of having one packing for many conditions.

Flexibility and resiliency are assured throughout the life of Kearsarge on account of its peculiar folded block or center construction, by the rubber expansion back or cushion which adds resiliency, and because rubber cement is entirely eliminated from the center block of the packing.

Kearsarge is constructed differently from other asbestos packing which may have the same exterior appearance. The block is formed by folding unrubbered asbestos cloth (same quality as used for the outside cover) back and forth, placing

the rubber expansion back on top and covering the block thus formed with two wraps of asbestos cloth. There is no chance, even if cover wears away, for part of the packing to get loose and work away, for the center is folded from one piece of fabric—each layer a continuation of the adjacent one.

When cover wears away the first fold is presented to wear, and this is as strong and durable as the cover itself, for it is made of the same material.

There is no rubber cement in the block or body, which entirely eliminates the possibility of its becoming hard by vulcanization. In assembling, the cover is so placed that it is impossible for it to be pulled or torn away from the body in service.

Sizes  $\frac{1}{2}$ ", and smaller, furnished with a twisted core instead of the folded block construction.

Furnished in Ring Style No. 150 and Spiral Style No. 166.

*Without* rubber expansion back, Ring Style No. 15 and Spiral Style No. 16.

## Kearsarge Rod Packing is packed as follows:

*Ring*—Unless otherwise specified, rings will be packed in boxes containing approximately the following weights:

Under 1" rod.....	3 pounds
1" to 2" rod.....	5 pounds
2" to 3" rod.....	10 pounds
3" to 4" rod.....	15 pounds
Over 4" rod.....	20 pounds

*Spiral*—Furnished in boxes, each containing one length of packing approximately  $12\frac{1}{2}$  feet long.

*Approximate weight per hundred feet of Kearsarge Packing treated with preserving liquid and graphite finish:*

$\frac{3}{8}$ ".....	13½ pounds
$\frac{1}{2}$ ".....	20 pounds
$\frac{5}{8}$ ".....	32 pounds
$\frac{3}{4}$ ".....	44 pounds
$\frac{7}{8}$ ".....	57 pounds
1".....	71 pounds





## Johns-Manville Kearsarge Packing No. 15, for Ammonia

**O**UR recommendation for ammonia compressor rods is No. 15 Kearsarge Rings.

No. 15 should be used only where flange or packing space is  $\frac{1}{2}$ " or over, as  $\frac{1}{2}$ " is the smallest size that can be made with the folded center construction, without friction in the folds, and it is this absence of

friction in the center of the packing which makes No. 15 so suitable for ammonia service.

For flanges smaller than  $\frac{1}{2}$ ", we recommend No. 222 Braided Mogul instead of the folded center or block used on the larger sizes.

## Johns-Manville Kearsarge Air Pump Packing



Style No. 15

**F**OR packing rods on the air and steam ends of air pumps. Johns-Manville Kearsarge Air Pump Packing is constructed of asbestos fabric folded, cut and molded to the proper shape and size to fit air pump rods and stuffing boxes. It is similar in material and construction to Style 150 Kearsarge Rod Packing described on

page 64—except that the rubber expansion back is eliminated.

This packing is thoroughly lubricated and is constructed with the minimum amount of rubber cement to lessen as far as possible the chance of its becoming hard in service due to high temperature.

### LIST OF SIZES

Style No. 475.....	For	6-inch Westinghouse Air Pump
Style No. 775.....	For	8-inch Westinghouse Air Pump
Style No. 875.....	For	8½-inch Westinghouse Air Pump
Style No. 675.....	For	9½-inch Westinghouse Air Pump
Style No. 2175.....	For	10½-inch Westinghouse Air Pump
Style No. 875.....	For	11-inch Westinghouse Air Pump
Style No. 975.....	For	Nos. 1 and 2 New York Air Pump
Style No. 1075.....	For	No. 5 New York Air Pump
Style No. 1175.....	For	No. 6 New York Air Pump



# Johns-Manville Duplex Rod and Plunger Packing



Coil Style No. 371



Ring Style No. 372

**F**OR packing rods and outside packed plungers where space between rod and inside of stuffing-box is  $\frac{3}{8}$ " or over, against hot or cold water at all pressures and temperatures.

The flax and rubber material used and the construction of Duplex Rod and Plunger Packing make it suitable for rod and outside-packed plunger hydraulic service.

Johns-Manville Duplex Rod and Plunger Packing is extremely durable, because the cover or wearing surface is made of a fabric of tightly twisted, closely woven flax yarn, which wears better than the surface of packing braided like ordinary flax.

The waterproof qualities of this packing

are high because the layers of rubber cement between the several layers of flax fabric form waterproof walls that prevent leakage through the packing.

Flexibility and resiliency are assured on account of these same layers of non-vulcanizing rubber cement and because of the rubber core in the center of the packing.

Maximum durability and efficiency are obtained because of the woven wearing surface and because of the resiliency or life of the packing, which makes the stuffing-box tight with the minimum amount of gland pressure on the packing.

Furnished in Coil Style No. 371, Ring Style No. 372 and Spiral Style No. 373.

## Duplex Rod and Plunger Packing is packed as follows:

*Ring*—Unless otherwise specified, rings will be packed in boxes containing approximately the following weights:

Under 1" rod.....	3 pounds
1" to 2" rod.....	5 pounds
2" to 3" rod.....	10 pounds
3" to 4" rod.....	15 pounds
Over 4" rod.....	20 pounds

*May be ordered in sets to fit rod and stuffing box exactly*

*Spiral*—Furnished in boxes, each containing one length of packing approximately  $12\frac{1}{2}$  feet long.

*Coil*—Furnished several coils to the box, the number depending upon the size of the packing.

*Approximate weight per hundred feet of Duplex packing treated with preserving liquid and graphite finish:*

$\frac{3}{8}$ ".....	10 pounds
$\frac{1}{2}$ ".....	17 pounds
$\frac{5}{8}$ ".....	24 pounds
$\frac{3}{4}$ ".....	34 pounds
$\frac{7}{8}$ ".....	45 pounds
1".....	52 pounds



## Johns-Manville Mogul Coil Packing



Twisted Style, No. 193



Braided Style, No. 222

**F**OR packing small rods, valve stems, etc., and where space between rod, stem or spindle and inside of stuffing-box is less than  $\frac{3}{8}$ " , or for packing conditions such as for oils and chemicals where no rubber is desired in the packing.

Made of long fibre asbestos yarn, twisted or braided into coil form, lubricated and graphited. The asbestos yarn and lubricating compound used in the manufacture of both braided and twisted

Mogul make it suitable for nearly any condition. It is a convenient all-around-the-plant packing, specially recommended for packing small rods and boxes, or for emergency use.

By untwisting the strands of Style 193, many smaller sizes may be obtained.

Furnished in coil form only, on spools and reels—Twisted Style No. 193; Braided Style No. 222.

### MOGUL PACKING IS PUT UP AS FOLLOWS:

Sizes $\frac{1}{8}$ " , $\frac{3}{16}$ " and $\frac{1}{4}$ "	both styles, on $\frac{1}{4}$ lb. spools, each spool in an individual carton, and packed 50 spools to a large carton.
Sizes $\frac{1}{8}$ " to $\frac{1}{2}$ "	both styles, on 1 lb. spools, or larger.
Sizes over $\frac{1}{2}$ "	both styles, on 5 lb. spools, or larger.

### APPROXIMATE WEIGHT OF 100-FOOT LENGTHS

Size Inches	Approximate Weight, pounds per 100-Foot length of Twisted No. 193	Approximate Weight, pounds per 100-Foot length of Braided No. 222
$\frac{1}{8}$	$1\frac{1}{4}$	$1\frac{1}{4}$
$\frac{1}{4}$	$3\frac{1}{4}$	$3\frac{1}{2}$
$\frac{3}{8}$	$7\frac{1}{4}$	$7\frac{3}{4}$
$\frac{1}{2}$	$12\frac{1}{2}$	$11\frac{1}{4}$
$\frac{5}{8}$	$24\frac{1}{2}$	$20\frac{1}{2}$
$\frac{3}{4}$	$28\frac{1}{4}$	$30\frac{1}{4}$
$\frac{7}{8}$	40	$42\frac{1}{2}$
1	$47\frac{1}{2}$	50



# Johns-Manville Universal Piston Packing

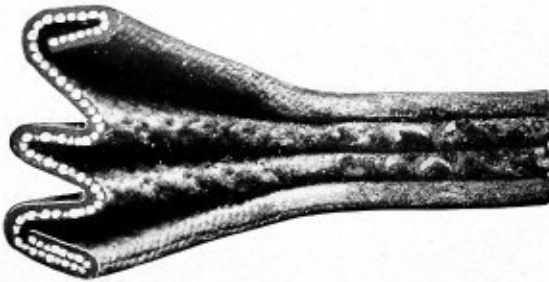

Cross-section of Coil Style No. 33, end opened to show construction.



Spiral Style No. 34

**F**OR packing the pistons of inside packed pumps against water, brine, air, oils and some chemicals, where packing space is  $\frac{3}{8}$ " or over. A combination of asbestos and cotton fabrics folded and molded together so as to present a wearing surface of rounded shoulders of most durable material. The back and forth folded construction of Universal Piston Packing makes it superior to the laminated type of hydraulic packing for the following reasons:

As this packing is made of continuous fabric folded back and forth, there are no separate laminations to work loose from one another by the side-wiping action against the pump cylinder walls. Thus the life of this packing is longer than that of any other hydraulic piston packing.

The folded construction gives Universal greater flexibility, resiliency and expansion in the direction desired, which also means longer service and less leakage or slippage past the packing when the pump is in service.

The rubber cement that holds the folds of Universal together is strong and tough. This packing is vulcanized in steel molds, so that the sizes are more accurate than laminated hydraulic packing, which is cut in strips from slab stock. Due to the methods and materials used in constructing Universal, it is very durable and more economical than other packings sold at a much lower per-pound price.

Coil Style No. 33; Spiral Style No. 34; Ring Style No. 35.

## JOHNS-MANVILLE UNIVERSAL PISTON PACKING IS PACKED AS FOLLOWS

*Coil*—Furnished in coils approximately 12 feet long, packed several coils to the box, depending upon the size of the packing and according to the following table:

Size of Packing	Coils per box
$\frac{3}{8}$ "	4 coils per box
$\frac{7}{16}$ "	3 coils per box
$\frac{1}{2}$ "	4 coils per box
$\frac{9}{16}$ "	3 coils per box
$\frac{5}{8}$ "	3 coils per box
$\frac{11}{16}$ "	2 coils per box
$\frac{3}{4}$ "	2 coils per box
$\frac{7}{8}$ "	2 coils per box
1"	2 coils per box

*Spiral*—Furnished in boxes, each containing one length of packing approximately 12 feet long.

*Ring*—Unless otherwise specified, rings will be packed in boxes containing approximately the following weights:

Under 1" rod	3 pounds
1" to 2" rod	5 pounds
2" to 3" rod	10 pounds
3" to 4" rod	15 pounds
Over 4" rod	20 pounds
May be ordered in sets to fit piston exactly.	

*Approximate weights of 100-foot lengths of Universal Piston Packing:*

$\frac{3}{8}$ "	10.5 pounds
$\frac{1}{2}$ "	18.7 pounds
$\frac{5}{8}$ "	27.1 pounds
$\frac{3}{4}$ "	41.8 pounds
$\frac{7}{8}$ "	52.0 pounds
1"	68.1 pounds





## Johns-Manville Universal Combination Steam Hammer Packing

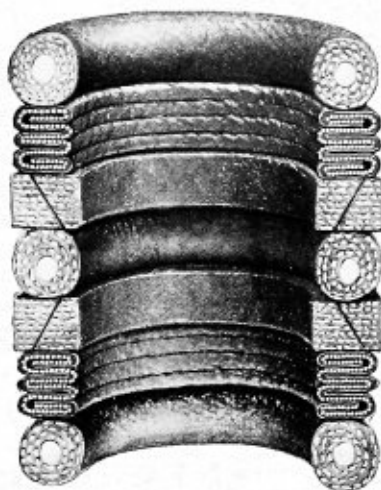

Universal Combination Ring,  
Style No. 29

**J**OHNS-MANVILLE Steam Hammer Packing is a combination of asbestos, cotton and rubber, and is particularly adapted to steam hammer service. The style of packing recommended depends upon whether the rod is round or has one or more flat sides and upon other conditions which vary considerably in different plants.

Steam hammer service is exceptionally severe on account of the unusual vibration, accumulation of dirt and grit on rods, and intermittent service. The forms of rings used in Universal—round, square, and diagonal cut—provide for vibration.

The wearing surface resists the wear

caused by dirt and grit, because the square rings have a wearing surface of rounded shoulders instead of laminated edges, and all the rings are made of a combination of cotton and asbestos fabrics which makes them most durable. The arrangement of the variously formed rings makes the set particularly flexible and resilient, and the contraction and expansion caused by intermittent service are also taken care of by this method of arrangement.

Furnished in Combination Ring, Style No. 29 only.

Special sets can be furnished for rods with flat sides.



## Johns-Manville Jewett Ring Packing

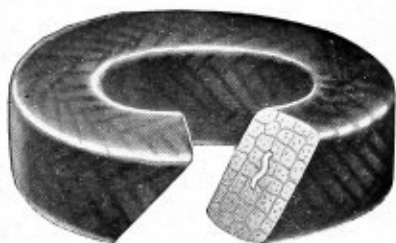

Style No. 10

**F**OR packing small rods and spaces where rings of exact dimensions are required or desired. Made of asbestos, cotton or flax yarn, (according to style and service), Jewett Rings are intended for packing small spaces, i. e., where the space between rod, spindle or shaft and the stuffing-box is less than  $\frac{3}{8}$ " and where

it is impossible to make other styles of packing in such small sizes.

All Jewett Rings are molded to exact shape and size in steel dies, so that they exactly fit rod and stuffing-box for which they are intended. They are made in several styles for different conditions as follows:

### Jewett Rings, Style No. 10

For any condition where a ring of small cross-section is required or where a packing with no rubber in its composition is preferable; i. e., for some chemical solutions, etc. This style is made

of wire-inserted asbestos yarn, braided into jackets one over another around a thin lead ribbon, lubricated, graphited and molded into ring form.

### Jewett Coil, Style No. 310

This packing is made of exactly the same material, and by the same method of construction as

Johns-Manville Jewett Rings, Style No. 10, but is furnished in coil form.

### Jewett Rings, Style No. 40

Especially adapted for hot water, light oils and gasoline service. Constructed similar to No. 10

except that flax yarn, without wire, is used instead of wire-inserted asbestos yarn.

### Jewett Rings, Style No. 3

For hot and cold water service. Especially designed for packing faucets, Fuller cocks and plumbing products. This packing is lubricated with mica instead of oil, so that it will not affect

the process of nickel-plating. Made with jute center with a braided cotton jacket or cover and molded to exact size. Furnished in white finish.



# Johns-Manville Universal Rod and Plunger Packing



Coil Style No. 30



Spiral Style No. 31



Ring Style No. 32

**F**OR packing rods and outside-packed plungers where space between rod and box is  $\frac{3}{8}$  of an inch or more—against steam, air, water and various fluids. Specially adapted where a packing with great resiliency is required.

Universal Rod Packing is made of asbestos and cotton fabrics, which have been treated with rubber cements, built up together and wrapped around a rubber core or cushion.

The combination of asbestos and rub-

ber produces a packing with great pliability and resiliency which is suitable for steam, air, hydraulic and various other conditions.

It is specially recommended for severe conditions such as high pressure hydraulic work, service where there is a great deal of vibration or where rods may be in poor condition or slightly out of alignment.

Furnished in Coil style No. 30, Spiral style No. 31 and Ring style No. 32.

## Universal Rod and Plunger Packing is packed as follows :

*Coil*—Furnished in coils approximately  $12\frac{1}{2}$  feet long, packed several coils to the box, depending upon the size of the packing and according to the following table:

$\frac{1}{4}$ "—8 coils	$\frac{1}{2}$ "—4 coils	$\frac{3}{4}$ "—2 coils
$\frac{5}{16}$ "—6 coils	$\frac{9}{16}$ "—3 coils	$\frac{7}{8}$ "—2 coils
$\frac{3}{8}$ "—4 coils	$\frac{5}{8}$ "—3 coils	1"—2 coils
$\frac{7}{16}$ "—3 coils	$\frac{11}{16}$ "—3 coils	

*Ring*—Unless otherwise specified, rings will be packed in boxes containing approximately the following weights:

Under 1" rod	3 pounds
1" to 2" rod	5 pounds
2" to 3" rod	10 pounds
3" to 4" rod	15 pounds
Over 4" rod	20 pounds

*Spiral*—Furnished in boxes, each containing one length of packing approximately  $12\frac{1}{2}$  feet long.

$\frac{1}{4}$ "	12 ounces
$\frac{5}{16}$ "	1 pound
$\frac{3}{8}$ "	1 pound, 4 ounces
$\frac{7}{16}$ "	1 pound, 8 ounces
$\frac{1}{2}$ "	1 pound, 13 ounces
$\frac{9}{16}$ "	2 pounds, 6 ounces
$\frac{5}{8}$ "	2 pounds, 14 ounces
$\frac{11}{16}$ "	3 pounds, 8 ounces
$\frac{3}{4}$ "	4 pounds, 4 ounces
$\frac{7}{8}$ "	5 pounds, 4 ounces
1"	6 pounds



## Johns-Manville Asbestos Wick Packing

*Furnished regularly in 1/2 and 1-lb. balls*

Johns-Manville Asbestos Wick is made in five standard styles:

Style 4202—A pure wick made from several strands of asbestos twisted together.

Style 4195—A single strand asbestos wick for ordinary requirements.

Style 199—A wick made from pure asbestos roving, in single strand form.

Style 202—A pure wick made from asbestos roving by twisting together several strands.

Style 4199—A single strand wick made of pure asbestos.

## Johns-Manville Asbestos Twisted Rope Packing

*Furnished 3/8" diameter and up, in 10, 25 and 50-lb. reels*

Johns-Manville Asbestos Twisted Rope is made in three standard styles:

Style 4200—A pure rope made from several strands of asbestos twisted together around an asbestos core.

Style 4196—A plain twisted asbestos rope for ordinary service.

Style 200—A pure rope made by twisting several strands of asbestos roving around an asbestos core.

## Johns-Manville Asbestos Braided Rope Packing

*Furnished in 10, 25 and 50-lb. reels*

Johns-Manville Canadax Braided Rope Packing, Round Style No. 566, Square Style No. 787. Made by braiding a commercially pure asbestos jacket over a pure asbestos twisted rope core. Made 1/4" and larger. Sizes 1/4" to 3/4" inclusive have one jacket; 7/8" and over, two jackets.

Johns-Manville Pure Braided Rope Packing, Round style No. 857, Square Style No. 869. Made by braiding a pure asbestos jacket over a pure asbestos twisted rope core. Made 1/4" and larger. Sizes

1/4" to 3/4" inclusive have one jacket; 7/8" and over, two jackets.

Johns-Manville Solid Braided Rope Packing, Round Style No. 702, Square Style No. 733. Made of commercially pure asbestos yarn, braided into jackets, one over the other, in sizes 1/4" and over.

Johns-Manville Pure Solid Braided Rope Packing, Round Style No. 788, Square Style No. 873. Made of pure asbestos yarn, braided into jackets, one over the other, in sizes 3/8" and larger.

## Johns-Manville Asbestos Cord

*Furnished in 1/2 and 1-lb. balls, 5 and 10-lb. spools, 25 and 50-lb. reels*

Fire and acid resisting Asbestos Cord, with strong, hard twisted strands. Especially valuable in glass and chemical works, and for suspending metals, retorts

and crucibles in contact with fire or heat.

Also used as a string packing on small valves.

Sizes: 1/16" to 3/8" in diameter.





## Johns-Manville Asbestos High Temperature Packing

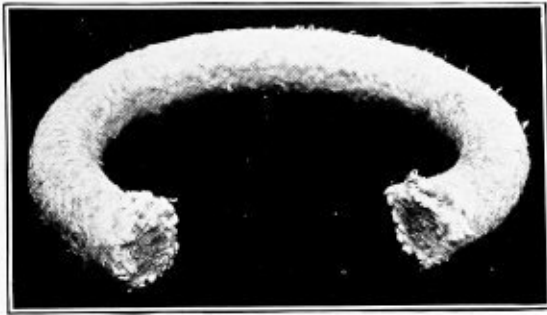

Ring Style No. 65

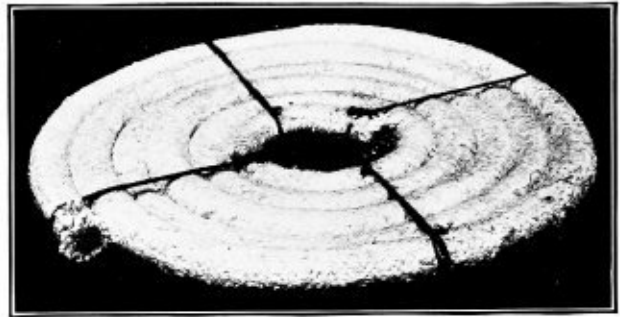

Coil Style No. 789-X

**F**OR packing rods, plungers, expansion joints, etc., where temperatures are so high that our regular packings manufactured of commercially pure yarn and containing our regular lubricants, are not suitable.

This packing is braided of pure asbestos yarn and iron wire, and is designed with the main object of resistance to high temperature. It should, therefore, never be used for ordinary temperatures, because it does not contain the special features of design and construction which make our standard packings so successful for the particular purposes for which they are recommended.

The smallest size which can be made is  $\frac{1}{4}$ ".

Sizes under  $\frac{1}{2}$ " are made with one plain braided asbestos jacket over a twisted asbestos core containing annealed iron wire.

Sizes  $\frac{1}{2}$ " and over are made with two plain braided asbestos jackets over a twisted asbestos core containing annealed iron wire.

The asbestos yarn used is pure.

No wire is used in any of the jackets.

Either the ring or the coil can be furnished either square or round and with or without graphite and lubricant, but will be furnished round and ungraphited and unlubricated unless otherwise ordered.



# Johns-Manville Special Combination Air Pump Packing



Air End  
Style No. 55



Steam End  
Style No. 15

**F**OR the safe and efficient operation of a locomotive, compressed air is not only highly important and necessary but also most vital. Compressed air can only be produced through the expenditure of that valuable agent—steam. Obviously, then, the packing used on locomotive air pumps on both steam and air ends of the rods should be the most efficient available. To this end, realizing full well that the best results would be obtained by treating the air and steam ends as two entirely different packing problems and not attempting to make one style of packing serve for two purposes, we have developed Johns-Manville Special Combination Air Pump Packing—designed to meet the most severe conditions encountered in this service.

The construction of each individual set that is intended for the air end is different from that intended for the steam end and the packings for the air ends and steam ends are packed respectively in separate cartons, each carton marked for the end of the pump for which it is intended.

The packing for the air end is a combination of asbestos yarn and copper wire formed into rings which are thoroughly lubricated, and which will withstand pressures and temperatures incident to this service without becoming hard and brittle.

The packing for the steam end is made of asbestos fabric thoroughly lubricated, formed, cut and pressed to proper size and is admirably adapted to steam end service.

## LIST OF SIZES

Style No. for Air End	Style No. for Steam end		
1055	1015	..... For	6-inch Westinghouse Air Pump
1155	1115	..... For	8-inch Westinghouse Air Pump
1255	1215	..... For	8½-inch Westinghouse Air Pump
1355	1315	..... For	9½-inch Westinghouse Air Pump
2155	2115	..... For	10½-inch Westinghouse Air Pump
1255	1215	..... For	11-inch Westinghouse Air Pump
1555	1515	..... For	Nos. 1 and 2 New York Air Pump
1655	1615	..... For	No. 5 New York Air Pump
1755	1715	..... For	No. 6 New York Air Pump



## Johns-Manville Moulded Air Pump Packing



**F**OR packing the rods on the steam and air ends of air pumps.

Each individual set of Johns-Manville Moulded Air Pump Packing consists of several convex and concave rings, the two end rings of the set being shaped to fit the packing gland and the bottom of the stuffing box, respectively.

The rings used in this type of packing are made of asbestos fibre and a suitable binder. This mixture is cured and moulded to the proper sizes and shapes, steel moulds being used.

Our experience in making this material has enabled us to develop an air pump packing which is very dense and yet resilient. The method of assembling the sets—i. e., convex and concave rings—insures a tight fit against the rod and also against the inside of the stuffing box.

Johns-Manville Moulded Air Pump Packing is especially adapted to conditions where there is considerable lubrication.

### LIST OF SIZES

Style No.	
404—For	6-inch Westinghouse Air Pump
400—For	8-inch Westinghouse Air Pump
440—For	8½-inch Westinghouse Air Pump
544—For	9½-inch Westinghouse Air Pump
4444—For	10½-inch Westinghouse Air Pump
440—For	11-inch Westinghouse Air Pump
168—For	Nos. 1 and 2 New York Air Pump
268—For	No. 5 New York Air Pump
368—For	No. 6 New York Air Pump

## Johns-Manville Keystone Air Pump Packing

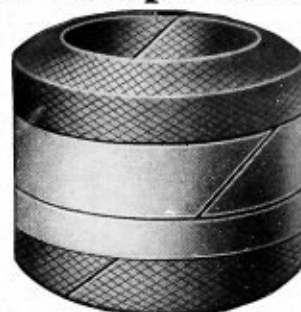

**F**OR packing the rods on the steam and air ends of Westinghouse and New York Air Pumps.

Each individual set of Johns-Manville Keystone Air Pump Packing consists of a pair of Johns-Manville Moulded Concave and Convex Rings on each end of which is placed a No. 10 Jewett Ring, bevelled to fit the bottom of the stuffing box and the packing gland.

The Johns-Manville Special Moulded Rings are made of asbestos and a suitable binding material which, when cured and pressed to shape and size in steel molds, make a hard and resilient ring with great density. They are built to resist high pressures and severe service.

The moulded Jewett Rings on each end of the set are made of asbestos yarn thoroughly lubricated, braided to proper size and pressed into steel molds of exact shape and size. These rings are softer than the Special rings and not only conform readily to the shape of the stuffing box and packing gland but provide for proper lubrication.

### LIST OF SIZES

Style No.	
300—For	6-inch Westinghouse Air Pump
700—For	8-inch Westinghouse Air Pump
800—For	8½-inch Westinghouse Air Pump
600—For	9½-inch Westinghouse Air Pump
2100—For	10½-inch Westinghouse Air Pump
800—For	11-inch Westinghouse Air Pump
900—For	Nos. 1 and 2 New York Air Pump
1000—For	No. 5 New York Air Pump
1100—For	No. 6 New York Air Pump



# Westinghouse and New York Air Pumps

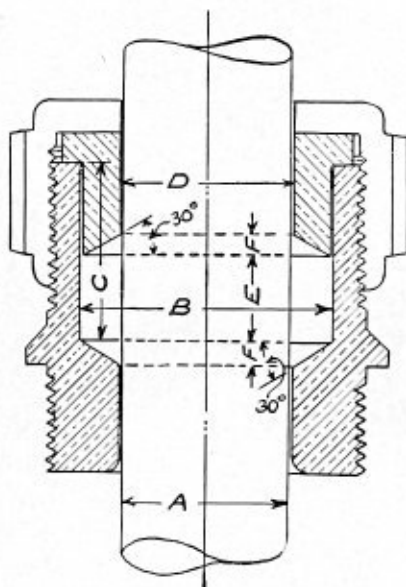

Cross section of typical stuffing box, identifying the dimensions given in the table below:

DIMENSIONS OF STUFFING BOXES AND SCHEDULE OF PACKINGS

SIZE OF PUMP	WESTINGHOUSE PUMPS						NEW YORK PUMPS										
	6"	8"	8 1/2"	9 1/2"	10 1/2"	11"	No. 1	No. 2	No. 3	No. 4	No. 5	No. 6	8"	8 1/2"	9 1/2"	11"	
A.....	1 3/8"	1 3/8"	1 3/4"	1 3/8"	2"	1 3/4"	1 1/4"	1 1/4"	1 1/4"	1 1/4"	1 1/2"	1 3/8"	1 3/8"	1 3/4"	1 3/8"	1 3/4"	1 3/4"
B.....	2 1/16"	2 1/16"	2 3/16"	2 1/16"	2 13/16"	2 9/16"	2"	2"	2"	2"	2 3/16"	2 1/16"	2 1/16"	2 3/16"	2 1/16"	2 1/16"	2 3/16"
C.....	1 7/16"	1 7/16"	1 1/2"	1 7/16"	1 1/2"	1 1/2"	1 3/8"	1 3/8"	1 3/8"	1 3/8"	1 1/2"	1 1/2"	1 7/16"	1 1/2"	1 7/16"	1 1/2"	1 7/16"
D.....	1 13/32"	1 13/32"	1 25/32"	1 13/32"	2 1/32"	1 25/32"	1 17/64"	1 17/64"	1 17/64"	1 17/64"	1 33/64"	1 25/64"	1 13/32"	1 25/32"	1 13/32"	1 25/32"	1 13/32"
E.....	1 1/16"	1 1/16"	1 1/16"	1 1/16"	1 1/16"	1 1/16"	1 1/16"	1 1/16"	1 1/16"	1 1/16"	1 1/16"	1 1/16"	1 1/16"	1 1/16"	1 1/16"	1 1/16"	1 1/16"
F.....	3/16"	3/16"	7/32"	3/16"	7/32"	7/32"	3/16"	3/16"	3/16"	3/16"	3/16"	3/16"	3/16"	3/16"	3/16"	3/16"	3/16"
No. of Stuffing Boxes per Pump	2	2	4	2	4	2	4	4	4	4	4	4	2	4	2	2	2
Depth of Pack'g	1 5/8"	1 5/8"	1 23/32"	1 5/8"	1 23/32"	1 23/32"	1 5/16"	1 5/16"	1 5/16"	1 5/16"	1 25/32"	1 23/32"	1 5/8"	1 25/32"	1 5/8"	1 23/32"	1 23/32"
Rings per Box	Kearsarge No. 15.....	4	4	4	4	4	4	4	4	4	4	4	4	4	4	4	4
	Combination 15-55.....	4	4	4	4	4	4	4	4	4	4	4	4	4	4	4	4
	Keystone.....	4	4	4	4	4	4	4	4	4	4	4	4	4	4	4	4
	Jewett.....	4	4	4	4	4	4	4	4	4	4	4	4	4	4	4	4
	Moulded.....	4	4	4	4	4	4	4	4	4	4	4	4	4	4	4	4
Style Numbers	Kearsarge No. 15.....	475	775	875	675	2175	875	975	975	975	975	1075	1175	775	875	675	875
	Combination No. 15 Steam End.....	1015	1115	1215	1315	2115	1215	1515	1515	1515	1515	1615	1715	1115	1215	1315	1215
	Combination No. 55 Air End.....	1055	1155	1255	1355	2155	1255	1555	1555	1555	1555	1655	1755	1155	1255	1355	1255
	Keystone.....	300	700	800	600	2100	800	900	900	900	900	1000	1100	700	800	600	800
	Jewett.....	450	750	550	650	2150	550	950	950	950	950	1050	1150	750	550	650	550
	Moulded.....	404	400	440	544	4444	440	168	168	168	168	268	368	400	440	544	440





## Johns-Manville Kearsarge Locomotive Throttle Packing



Style No. 15

**J**OHNS - MANVILLE Style No. 15 Kearsarge Locomotive Throttle Packing is the same as Style No. 150 Kearsarge Rod Packing, as described on page 64, except that it does not have the rubber expansion back, which is usually found in high pressure packing.

This packing is made of asbestos fabric, formed, cut and moulded to proper size. All rings are thoroughly lubricated. Because of the Johns-Manville method of manufacturing and folding the fabric and lubricating it, the packing is more resilient and durable than other rod packings.

Permanent softness is obtained by saturating the packing with a preserving liquid that preserves its softness in service. The folded block construction allows the packing to be more thoroughly saturated with the preserving liquid than when a tubular or other form of block, fastened together with rubber cement, is used, as in the latter construction the rubber cement prevents to some extent the preserving liquid penetrating to the center of the packing.

No rubber cement is used in the center folded block of the packing. This elim-

inates the weak part of most packings and eliminates any chance of the center becoming hard in service, as there is no rubber cement to vulcanize.

The cover is applied to the block of the packing so that it is impossible for it to be pulled loose or torn away from the body of the packing in service.

As there are only two pieces of fabric used in the construction of Kearsarge, and as the center or block is formed of one continuous piece of fabric, it is impossible for parts of the packing to become loose and work out of place when in service, as is the case of packings consisting of several tubes of braided fabric, held together by rubber cement, or several tubes braided one over another.

This packing is made from the best heat-resisting materials and therefore does not become hard in the stuffing-box.

It is especially efficient where there is considerable condensation, a condition that is very difficult to handle satisfactorily with other types of throttle packing.

Made in sets to fit stuffing-box according to exact diameter of rod, inside diameter and depth of stuffing-box, as given.



## Johns-Manville Pump Packing Recommendations

Use **JOHNS-MANVILLE SEA RINGS** for all Rods and Outside Packed Plungers. They are the **BEST PACKING** for the following reasons:

1. They *save power*, because they are absolutely automatic in action and the pressure of the packing on the rod is proportional to the pressure through the stuffing box. For this reason, the packing grips the rod *only* when there is a tendency to leakage and *in proportion* to the tendency to leakage.
2. They provide *Packing Standardization*—the elimination of various types of packing for different conditions, because they are constructed of such materials and so designed as to be the *best packing obtainable* for nearly all conditions.
3. They *last longer than other packings* because they are designed to operate automatically and are subject to pressure and wear only when necessary to prevent leakage. The materials used are the best obtainable.

For the **BEST RESULTS** pack pumps as follows:

- A—Sea Rings
  - B—Sea Rings
  - C—Sea Rings
  - D—Sea Rings
- Except where rod or plunger is under 3/4" diameter or space between rod and stuffing box is less than 3/8", in which cases use Mogul Coil, Twisted No. 193, Braided No. 222.
- E—Universal Piston—Coil No. 33, Spiral No. 34, Ring No. 35.
  - F—Pump Valves No. 206.

Packings that may be used but which are dependent upon gland pressure—the best of their class:

- A—Kearsarge—Ring No. 150, Spiral No. 166.\*
- B—Kearsarge—Ring No. 150, Spiral No. 166.\*
- C—Duplex—Coil No. 371, Ring No. 372, Spiral No. 373.\*
- D—Duplex—Coil No. 371, Ring No. 372, Spiral No. 373.\*

\* Except where space between rod and stuffing box is less than 3/8", in which case use: Mogul Coil, Twisted, 193; Braided, 222.

F—Johns-Manville Rubber Pump Valves.

NOTE: For special conditions such as the pumping of chemicals, etc., consult nearest Johns-Manville office.

Outside Packed Type of Pump.

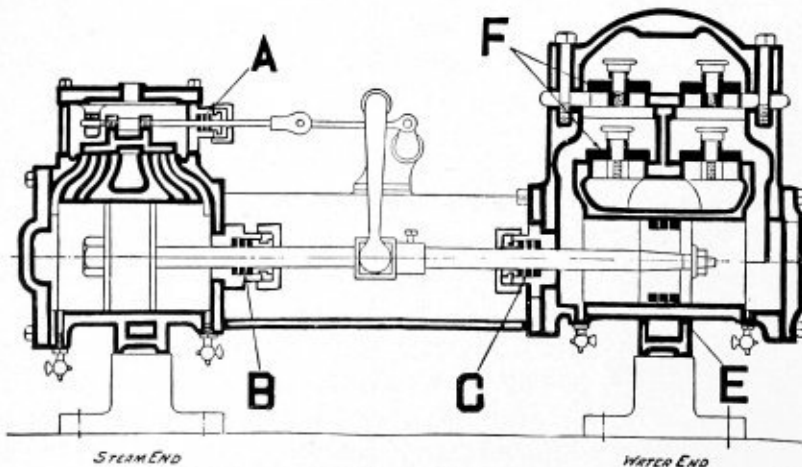
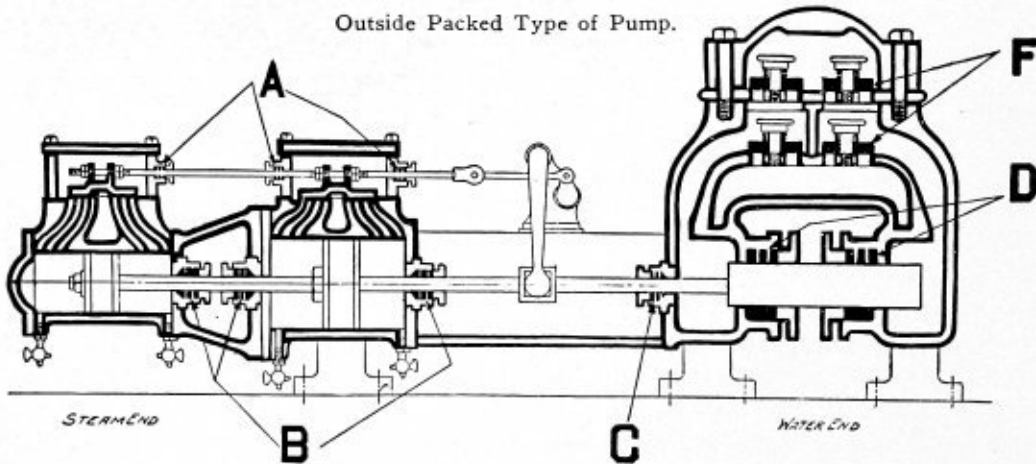

Inside Packed Type of Pump.

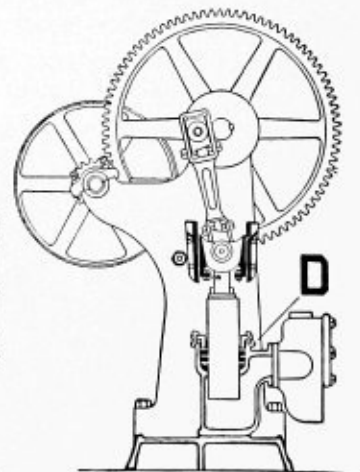

Vertical Outside Packed Type of Pump.



# Johns-Manville Service Sheet Packing

Style No. 60

**F**OR packing parallel surfaces of flanges against steam (superheated or saturated), air, water, ammonia, oil and various acidulated and alkaline or other chemical solutions. Johns-Manville Service No. 60 is a sheet designed to give satisfactory service under practically any conditions where a sheet would be used. *It has given and will give* satisfactory service where other sheet packings have failed.

The proper combination of Asbestos and bonding materials thoroughly mixed and felted together under enormous pressure has produced a sheet that is pliable, resilient, adaptable to all general work, and which does not deteriorate with age.

This obviates the necessity of stocking several sheets for different conditions, which not only reduces waste and loss due to deterioration but also eliminates the use of a wrong sheet for a certain service.

Scrap, consisting of center and corner pieces, may be saved and used at some future time, thus greatly reducing loss due to waste.

It is so dense and yet so resilient that it may be used in thicknesses one-half as great as sheets of rubber or other materials.

Taking into consideration the density, resiliency and light weight of Service Sheet, it is more economical to use than rubber and many other types of sheet packing sold at lower per-pound prices.

*Surface finish*—One instead of both sides of the sheet is graphited. Gaskets cut from



A sheet packing which makes better joints, wears longer and can be used for many conditions.

a sheet graphited on one side only are better than those cut from an ungraphited sheet, or a sheet graphited on both sides, because one side of the gasket will stick to the flange and the other side will come loose. This keeps the gasket in shape when repairs are being made so it may be used again, seating itself in the same place as when the joint was originally made; and the sheet is also much easier to handle.

Furnished in standard sheets 54" x 63" and 54" x 126" and in thicknesses of  $\frac{1}{64}$ ",  $\frac{1}{32}$ " and  $\frac{1}{16}$ "; also made  $\frac{1}{8}$ " and  $\frac{3}{32}$ " thick.  $\frac{1}{32}$ " and  $\frac{1}{16}$ " thicknesses also furnished in sheets 108" x 126".

SERVICE SHEET PACKING WEIGHS APPROXIMATELY:

	$\frac{1}{16}$ " thick	$\frac{1}{32}$ " thick	$\frac{1}{64}$ " thick
Per square yard .....	5.4 lbs.	2.7 lbs.	1.4 lbs.
Per square foot .....	.6 lbs.	.3 lbs.	.15 lbs.
Per square inch .....	.0041 lbs.	.002 lbs.	.001 lbs.



# Johns-Manville Seigelite Sheet Packing

Style No. 711

**A**PPROVED by Underwriters' Laboratories, Inc., for use against hazardous liquids.

For packing flanges or joints against gasoline, benzine, oil, greases, hot or cold water and air. A fibrous material that resists the action of any of the above fluids, because it contains no rubber or rubber substitutes that are soluble in oil or gasoline. It has a very high tensile strength and when immersed in water or other fluids becomes extremely tough, resembling rawhide.

It is more desirable than rubber or rubber cloth insertion sheets for hydraulic service, on account of its strength.

It is sold by the square yard, is comparatively low in price and can be used with greater economy and efficiency than "black oil proof" rubber sheet; "red rubber sheet"; and C. I. (cloth insertion) sheet. The face of Seigelite sheet is ruled off with black lines into 1-inch squares to facilitate cutting to any desired exact size without measurement.

In general, Johns-Manville Seigelite is



Seigelite Sheet Packing contains no rubber or similar materials. It assures better and more economical service for many purposes.

recommended for making joints on pipe flanges, gasoline pumps, and plumbing specialties; used extensively by power plants, mills and factories, auto repair shops, automobile manufacturers, gas-engine manufacturers, the motor-boat trade, steam-fitters and plumbers.

## SIZES, WEIGHTS AND LIST PRICES

Thickness	Width	Length	Approximate Weight per Sq. Yd.	List Price per Sq. Yd.
.01 inch	Approximately 48 inches	25 or 50-yard rolls	8 oz.	\$0.85
$\frac{1}{64}$ inch	Approximately 48 inches	25 or 50-yard rolls	13 oz.	1.05
.02 inch	Approximately 48 inches	25 or 50-yard rolls	1 lb.	1.35
$\frac{1}{32}$ inch	Approximately 48 inches	25 or 50-yard rolls	1.7 lbs.	1.90
$\frac{1}{16}$ inch	Approximately 48 inches	25 or 50-yard rolls	3.5 lbs.	4.50
$\frac{3}{32}$ inch	Sheets only, 36" x approximately 48"		5.1 lbs.	6.80
$\frac{1}{4}$ inch	Sheets only, 36" x approximately 48"		7.0 lbs.	9.20
$\frac{5}{16}$ inch	Sheets only, 36" x approximately 48"		10.5 lbs.	13.50
$\frac{1}{2}$ inch	Sheets only, 36" x approximately 48"		14.0 lbs.	18.20
$\frac{3}{8}$ inch	Sheets only, 36" x approximately 48"		17.5 lbs.	22.60

NOTE—The above weights are only approximate, because the weight of this material changes, depending upon the quantity of moisture in the atmosphere. After a period of dampness it will weigh more than when dry.





# Johns-Manville Kearsarge Asbesto-Metallic Sheet Packing

Style No. 100

**G**ENERALLY used where surfaces are somewhat rough or uneven and where a sheet of a soft nature is therefore required. This packing is constructed of tightly twisted asbestos yarn, spun with brass wire to give additional strength, woven into Asbesto - Metallic



cloth and impregnated with Johns - Manville Heat-Resisting Compound.

Furnished in rolls 40" wide, about 250 lbs. each, in  $\frac{1}{32}$ " and  $\frac{1}{16}$ " thickness. Can be furnished graphited on one or both sides, if desired.

# Johns-Manville Mobilene Sheet Packing

Style No. 101

For packing gas and gasoline engine parts. While Johns-Manville Service Sheet Packing is our recommendation for gas engines and garage service, Mobilene, a pioneer gas engine packing, is still frequently demanded for packing cylinder-head joints and various parts of gas and gasoline engines. This packing is made of asbestos fabric of great strength, interwoven with fine brass wire



and impregnated with a special compound to withstand the high temperatures incident to this service. It has red compound on one side, so that the packing will stick to the flange when joint is broken, and graphite on the other to allow joint to be easily taken part.

Furnished in rolls 40" wide, 250 lbs. each;  $\frac{1}{32}$ " and  $\frac{1}{16}$ " thick.

# Johns-Manville Liberty Red Rubber Sheet Packing

Style No. 107, without wire

Style No. 108, wire-inserted

For medium or low pressure steam and hydraulic service. Manufactured from a special heat-resisting rubber compound of the highest quality, is comparatively light

in weight, and will not deteriorate rapidly. Furnished plain or with wire insertion, in rolls 36" wide and weighing about 200 to 250 lbs. each;  $\frac{1}{32}$ ",  $\frac{1}{16}$ " and  $\frac{1}{8}$ " thick.



## Johns-Manville Kearsarge Standard Asbesto-Metallic Boiler Manhole, Handhole and Tube Plate Gaskets

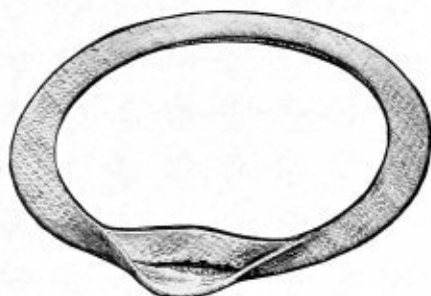

Better and longer service is obtained from Kearsarge Asbesto-Metallic Gaskets because of the greater strength of the unbroken round shoulder presented to the pressure

**F**OR packing manhole and handhole plates of boilers. Made of Asbesto-Metallic fabric treated with a heat-resisting compound, and folded into several plies or thicknesses to proper size and shape. Furnished in oval form to fit plates for which they are intended. The gaskets are made so that an unbroken rounded shoulder comes on the outside of the gasket which is presented to the pressure.

The edges of the folds are on the inside of the gasket.

Kearsarge Gaskets may be used over again if properly applied. On this account and because of their light weight, they are most economical gaskets to use.

Furnished in Style No. 116 for manholes, No. 117 for handholes, and No. 119 for tube plates.

## Johns-Manville Kearsarge Jointless Tube Plate Gaskets Style No. 118

For B. & W. and Heine tube plates. Made of Asbesto-Metallic fabric treated with heat-resisting compound and folded into several plies or thicknesses to proper size and shape.

Johns-Manville Kearsarge Jointless Tube Plate Gaskets, Style No. 118, are made seamless, without a joint, from Asbesto-Metallic yarn, woven into hose or tubular form and properly folded.

The advantage in using jointless gaskets for tube plate work is that there is no tape joint to interfere with perfect seating, so necessary when gaskets with a very narrow flange are used.

These gaskets are light in weight, very strong and treated with the same high-heat resisting compound used in the manufacture of Johns-Manville Kearsarge Standard Gaskets.

### Directions for application of Johns-Manville Kearsarge Manhole and Handhole Gaskets

Best results are obtained by placing a gasket on the manhole or handhole plate, then rubbing as much dry flaked graphite as possible on the exposed surface. The plate is then put into place. Before removing, the plate and boiler shell should be marked so that it can be replaced

in exactly the same position. If this method is followed, the gasket always seats in the same place. The graphite prevents the gasket from sticking to the boiler shell, while the ungraphited side next to the manhole or handhole plate makes gasket adhere to plate when withdrawn.



## Johns-Manville Kearsarge Asbesto-Metallic Gasketing Tape

**F**OR making odd or irregular shaped gaskets to pack joints against steam, air, water, ammonia and various acidulated, alkaline, and other chemical solutions. Made of Asbesto - Metallic yarn, woven into fabric and treated with a high-heat resisting resilient cement.

This material is gener-

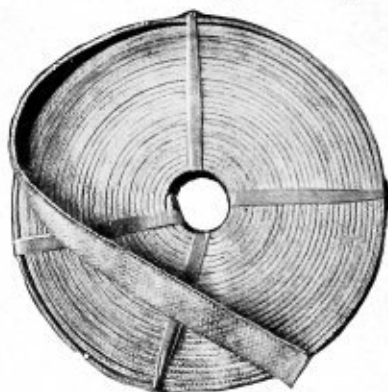

Style No. 120

ally used when a softer gasketing than Johns-Manville Service Sheet Packing is required, on account of rough surfaces to be packed.

Furnished in widths  $\frac{1}{2}$ " and greater, and in thickness  $\frac{1}{16}$ ",  $\frac{1}{8}$ ",  $\frac{3}{16}$ " and  $\frac{1}{4}$ ". Put up in 5 and 10 lb. rolls. Cannot be made in widths less than  $\frac{1}{2}$ ".

### APPROXIMATE WEIGHTS PER 25 FEET OF KEARSARGE TAPE, STYLE NO. 120

Width	$\frac{1}{8}$ " Thick	$\frac{1}{4}$ " Thick	$\frac{3}{8}$ " Thick	$\frac{1}{2}$ " Thick
$\frac{1}{2}$ Inches.....	1 $\frac{1}{4}$ Pounds.....	2 Pounds.....	3 Pounds.....	2 $\frac{1}{2}$ Pounds.....
$\frac{3}{4}$ ".....	1 $\frac{7}{8}$ ".....	3 ".....	4 ".....	3 $\frac{3}{4}$ ".....
1 ".....	2 $\frac{1}{2}$ ".....	4 ".....	5 $\frac{1}{4}$ ".....	5 ".....
1 $\frac{1}{4}$ ".....	3 $\frac{1}{8}$ ".....	5 $\frac{3}{4}$ ".....	6 $\frac{7}{8}$ ".....	6 $\frac{1}{4}$ ".....
1 $\frac{1}{2}$ ".....	3 $\frac{3}{4}$ ".....	6 $\frac{7}{8}$ ".....	7 $\frac{7}{8}$ ".....	7 $\frac{1}{2}$ ".....
1 $\frac{3}{4}$ ".....	4 $\frac{3}{8}$ ".....	7 $\frac{7}{8}$ ".....	10 ".....	8 $\frac{3}{4}$ ".....
2 ".....	5 ".....	10 ".....		10 ".....

## Johns-Manville Kearsarge Asbesto-Metallic Tubular Gasketing

To make manhole and handhole gaskets for boilers in cases of emergency, or wherever a gasket with a round cross-section is required, as in the case of grooved flanges.

Made by rolling the same Asbesto-Metallic fabric used in the manufacture of Kearsarge Standard Gaskets into coils of round section with a hollow center. This gasketing is primarily an emergency packing, but is used quite extensively for making odd or irregular-shaped gaskets, or for packing joints where grooves are provided for the packing to rest in, as

in the case of the doors of sterilizers, etc.

Kearsarge Asbesto - Metallic Tubular Gasketing is packed in boxes weighing approximately 5 lbs. or boxes weighing approximately 10 lbs., the number of 12 $\frac{1}{2}$ -foot lengths per box depending upon the size of gasketing. Tape and lead are furnished with gasketing.



Style No. 124

### Approximate Weights of 12 $\frac{1}{2}$ -foot lengths.

Size of Gasketing.	Approx. Weight
$\frac{3}{8}$ Inch	1 Pounds
$\frac{1}{2}$ " "	1 $\frac{5}{8}$ " "
$\frac{5}{8}$ " "	2 $\frac{1}{2}$ " "
$\frac{3}{4}$ " "	3 $\frac{3}{4}$ " "



## Johns-Manville Service and Seigelite Gaskets

**W**HERE gaskets cut and ready for application are desired, we shall be pleased to quote on application, on sizes or sketches submitted. We are prepared to cut and furnish gaskets from any of our sheet packings. Inquiries should be accompanied with complete dimensions or sketches. Service and Seigelite are adapted to practically any conditions and we advise using gaskets cut from either of these materials whenever possible.

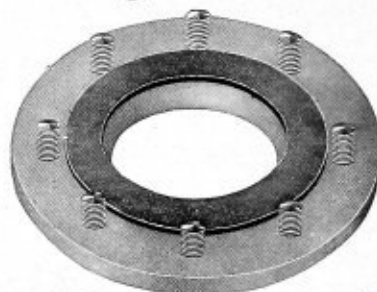

We recommend the ring type gasket. It makes a tighter, better and more economical joint than the full cut gasket and avoids fussing with bolt holes, etc.

### Service Gaskets Style No. 61

Johns-Manville Service Gaskets No. 61 are cut from Johns-Manville Service Sheet No. 60, described on page 79, and

may be used for any variety of conditions. Standard in thicknesses of  $\frac{1}{64}$ ",  $\frac{1}{32}$ " and  $\frac{1}{16}$ ".

### Ring Flange Joint Gaskets Style No. 61

#### FOR STANDARD FLANGES

* Size Pipe, Inches	Outside Diam., Inches	List Price, Each
$\frac{3}{4}$	$2\frac{1}{8}$	\$0.06
1	$2\frac{1}{2}$	.09
$1\frac{1}{4}$	$2\frac{1}{2}$	.12
$1\frac{1}{2}$	$3\frac{3}{8}$	.15
2	$4\frac{1}{8}$	.19
$2\frac{1}{2}$	$4\frac{7}{8}$	.28
3	$5\frac{3}{8}$	.32
$3\frac{1}{2}$	$6\frac{3}{8}$	.44
4	$6\frac{7}{8}$	.46
$4\frac{1}{2}$	7	.46
5	$7\frac{3}{4}$	.55
6	$8\frac{3}{4}$	.62
7	10	.80
8	11	.90
9	$12\frac{1}{2}$	1.18
10	$13\frac{3}{8}$	1.19
12	$16\frac{1}{8}$	1.76
14	$17\frac{3}{4}$	1.88
15	19	2.14
16	$20\frac{1}{4}$	2.42
18	$21\frac{5}{8}$	2.25
20	$23\frac{7}{8}$	2.68
22	26	3.02
24	$28\frac{1}{4}$	3.49
26	$30\frac{1}{2}$	4.00
28	$32\frac{3}{4}$	4.54
30	$34\frac{5}{8}$	4.70

#### FOR EXTRA HEAVY FLANGES

* Size Pipe, Inches	Outside Diam., Inches	List Price, Each
1	$2\frac{3}{4}$	\$0.11
$1\frac{1}{4}$	$3\frac{1}{4}$	.14
$1\frac{1}{2}$	$3\frac{7}{8}$	.20
2	$4\frac{3}{8}$	.24
$2\frac{1}{2}$	$5\frac{1}{8}$	.30
3	$5\frac{7}{8}$	.42
$3\frac{1}{2}$	$6\frac{1}{2}$	.50
4	$7\frac{1}{8}$	.52
$4\frac{1}{2}$	$7\frac{3}{4}$	.63
5	$8\frac{1}{2}$	.75
6	$9\frac{7}{8}$	.97
7	11	1.13
8	$12\frac{1}{8}$	1.26
9	13	1.43
10	$14\frac{1}{4}$	1.62
12	$16\frac{5}{8}$	2.22
14	$19\frac{1}{8}$	3.00
15	$20\frac{1}{4}$	3.10
16	$21\frac{1}{4}$	3.61
18	$23\frac{1}{2}$	4.00
20	$25\frac{5}{8}$	4.50
22	$27\frac{3}{4}$	4.90
24	$30\frac{3}{8}$	5.76

NOTE:—The sizes given above, up to and including 12 inch, are the nominal inside diameters of the pipe. Sizes above 12 inch are

the nominal outside diameters of the pipe. Be sure that your flanges are standard and check with the above when ordering.

### Seigelite Gaskets Style No. 712

Seigelite Gaskets No. 712 are cut from Seigelite Sheet No. 711, described on page

80. Furnished in thicknesses of .01",  $\frac{1}{64}$ ", .02",  $\frac{1}{32}$ ",  $\frac{1}{16}$ ".





## Johns-Manville Moulded Packing Cups

**J**OHNS-MANVILLE Moulded Packing Cups have many advantages over leather, which is the material generally used.

1. Made from either asbestos, duck, or other fabric, according to temperatures and other conditions. The compound and method of cure can be varied to suit requirements, thus giving greater control over the characteristics of Johns-Manville Moulded Cups than is possible with leather.

2. So processed that their dimensions and shapes tend to remain accurate, whereas leather has a tendency to flatten.

3. Leather cups must be made of one thickness or ply. In moulding this to the shape required, internal strains are produced which weaken the cup in its final

form. In the manufacture of Johns-Manville cups, such heavy distortion is not necessary.

4. Asbestos cloth resists high temperatures which cannot be handled by leather cups.

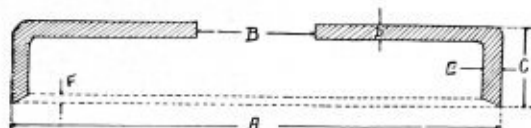

Type No. 1

This type used in steam brake cylinders, air hoists, pneumatic chucks, hydraulic presses, valves, etc. The cup is mounted on the rod or plunger, a turned down portion of which passes through the hole in the cup, which is held by a follower plate, usually tightened against the body of the cup by a nut on the rod or plunger.

We can make other types of packing cups as special shapes. In such cases, full particulars should be sent.

Form PB1

### Packing Cup Data Sheet

Printed in U.S.A.

THIS FORM IS TO BE USED IN SENDING IN DATA FOR ESTIMATE, AND ALSO MUST ACCOMPANY ALL ORDERS

Customer's Name..... Order No.....

Customer's Address.....

**JOHNS-MANVILLE INC.**..... **Branch**

123, 3162-1100P

1. Service for which cups are to be used.....  
*(State, whether steam, hot water, cold water, air, oil, etc.)*

2. Machine on which cups are to be used.....

*(State briefly whether it is a brake, press, accumulator, pump, plunger elevator, etc. If possible, state name of manufacturer. It is not necessary to give any manufacturer's serial number or sizes of cylinder, etc.)*

3. How are cups lubricated?.....

4. Pressure to come on packing in lbs. per sq. in.....

5. Temperature of liquid or gas.....

6. What does our cup replace?.....

7. If any remarks, use other side of sheet, and check here.....

#### Type No. 1

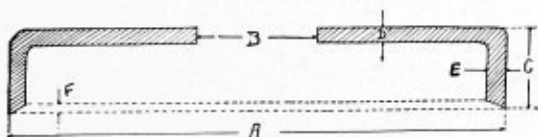

8. Diameter of cylinder in which cup operates..... inches

9. Is cylinder perfectly round and smooth?.....

10. If not, give particulars.....

11. Dimensions: "A"..... "B"..... "C"..... "D"..... "E"..... "F".....

*(If any variation is permissible in above dimensions, indicate in spaces above, as "C" 1" to 2".)*

12. Give mould number of suitable cup, if possible.....

#### Special Types

13. Make dimensioned sketch on back of this sheet to show all packing conditions and add remarks necessary to make them clear.

Date.....

Signed.....



## Johns-Manville Rubber Pump Valves

Johns-Manville Cold Water Pump Valves, Style No. 416—A medium hard valve for cold water, fresh, salt or alkaline.

Johns-Manville Condenser Valves, Style No. 420—A soft, red condenser valve for lake, marine, and other severe condenser conditions.

Johns-Manville Hot Water Pump Valves, Style No. 424—A hard valve for hot water, oily and alkaline solutions. Will stand temperatures up to 250° F.

## Johns-Manville Pump Valves

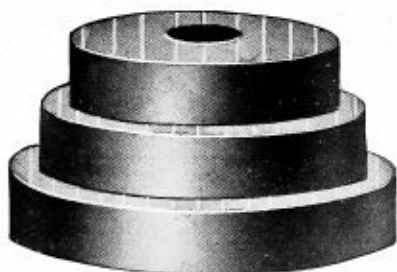

Style No. 206

Molded from a specially prepared grade of Asbestos Compound stock under tremendous pressure and at a high temperature.

Style No. 206 Pump Valves will satisfactorily meet almost any condition encountered in pump work. Therefore, their use eliminates the necessity of using many valves of various densities for different conditions. Will not quickly deteriorate when kept in stock.

Exceptional economy is afforded by the use of Style No. 206 valves on account of their life as compared with rubber and other valves. Although hard and dense, they possess the desirable quality of re-

siliency which makes them suitable for low-pressure as well as high-pressure conditions.

## Johns-Manville Top Head and Bottom Head Gaskets for Air Pumps

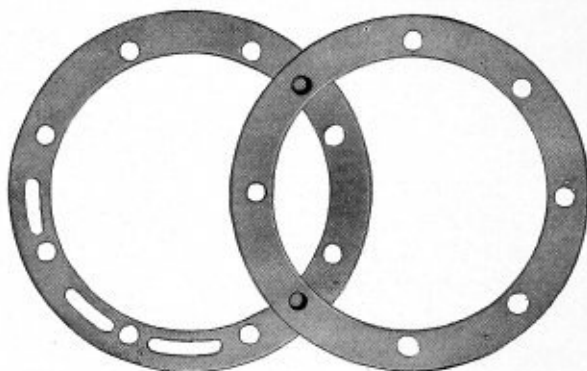

Service Style No. 61

Johns-Manville Top Head and Bottom Head Gaskets are cut from material suitable for this class of service.

Prices depend upon the size of pump for which the gaskets are intended to be used, either New York or Westinghouse.

## Johns-Manville Union Washers

For packing "Standard" and "Crane" unions. These washers are designed to meet the demand for a satisfactory packing for pipe unions and are especially adapted for service in steam, hot water, ammonia and gas pipes. They are made of Johns-Manville Service Sheet.

Furnished 1/16" or 1/8" thick.

When ordering Union Washers, specify whether "Standard," "Crane Standard C," or "Crane" are wanted.

For "Standard" . . . . . Style No. 139

For "Crane" . . . . . Style No. 140

For "Crane Standard C" Style No. 140-C

Johns-Manville  
Asbesto-Metallic  
Friction Blocks  
*and*  
Brake Band Lining

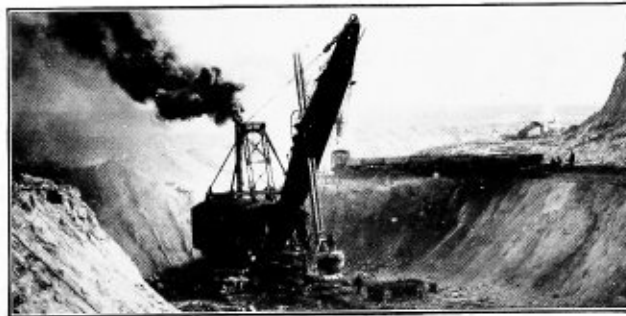



## Johns-Manville Asbesto-Metallic Friction Blocks

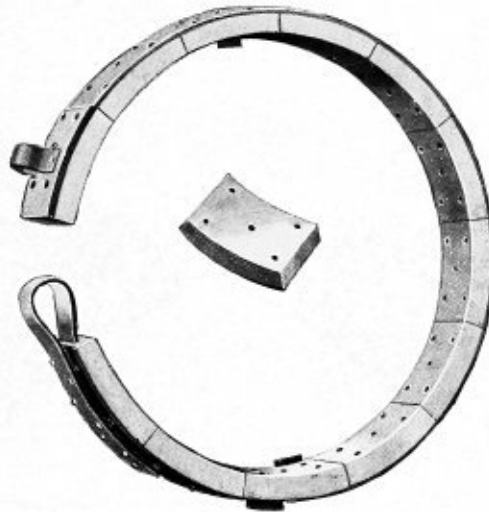

Showing Johns-Manville Asbesto-Metallic Friction Blocks applied to a brake band.

**F**OR friction brakes as used on hoists, cranes, steam shovels, dredges, and all similar machinery, also for friction clutches of all types, or for any braking or power transmitting duty where friction material is used. Made of selected asbestos fibre, brass or copper wire, and a special binding compound, densely compacted together by vulcanizing under enormous pressure in metal molds to the exact form required.

Johns-Manville Asbesto-Metallic Friction Blocks wear many times longer than wood, leather and various other materials. Economy is effected not only on account of their durability, but by minimizing shut-downs and reducing time and labor made necessary by replacement of other forms of braking materials.

These blocks grip smoothly and powerfully and release quickly, yet with the minimum of shock to the machine to which they are applied. Machinery equipped with Johns-Manville Asbesto-

Metallic Blocks is always under perfect control, as far as the brakes or frictions are concerned.

Johns-Manville Asbesto-Metallic Friction Blocks will not char, burn or cause fire, and are practically unaffected by moisture, heat or oily surfaces.

The high friction co-efficient or gripping power of these blocks means that less effort is necessary to control the machine on which they are applied than with many other braking materials.

The friction co-efficient of Johns-Manville Asbesto-Metallic Friction Blocks remains more nearly constant than that of other materials, under adverse conditions, such as presence of oil, moisture, or excessive heat due to heavy service. This results in uniform braking action at all times, without frequent adjustment.

Due to its high heat-resisting properties and resistance to wear, this material can be used in smaller areas of friction surface than other materials.



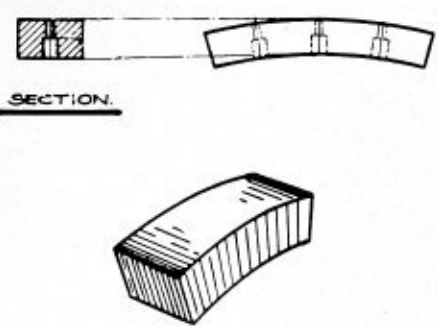
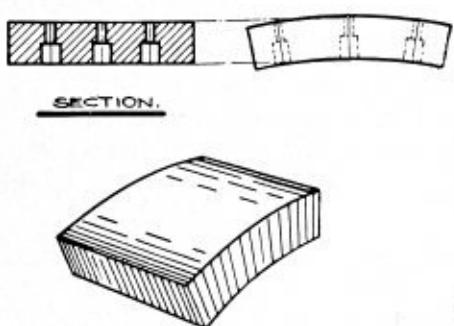
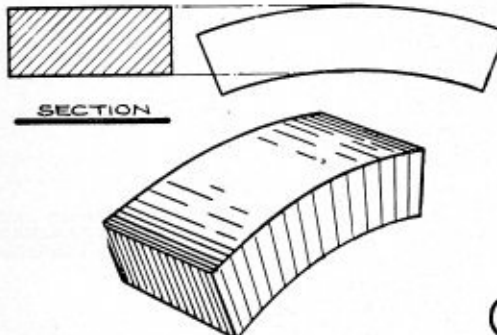
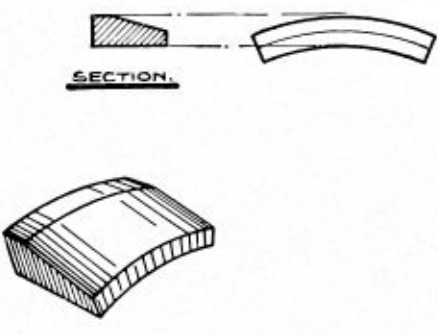
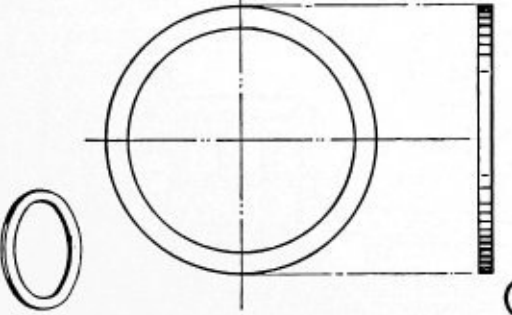
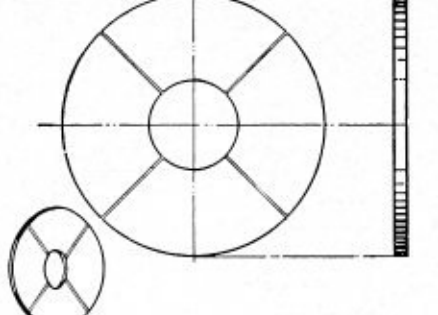
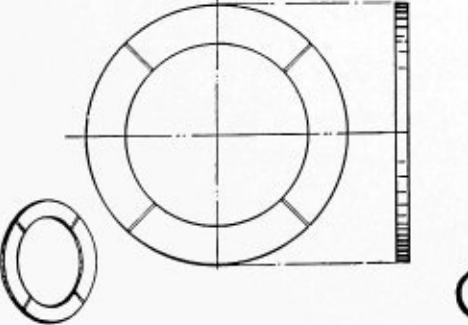

## Forms in which Asbesto-Metallic Friction Blocks have been furnished

 <p>SECTION.</p> <p>①</p>	 <p>SECTION.</p> <p>②</p>
 <p>SECTION</p> <p>④</p>	 <p>SECTION.</p> <p>①⑥</p>
 <p>⑧</p>	 <p>⑨</p>
 <p>⑩</p>	<p><b>Description of Diagrams</b></p> <p>Blocks Nos. 1, 2, 4, 16—Types frequently used for steam-shovels, dredges, stationary hoists, coal-dock and mine-hoisting machinery.</p> <p>Blocks Nos. 8, 9, 10.—Types frequently used for multiple disc clutches and brakes.</p> <p>It is possible to mould Asbesto-Metallic Friction Blocks in a variety of forms for various services.</p>



## How and Where Johns-Manville Asbesto-Metallic Friction Blocks May Be Used

**S**KETCHES are not intended to show proper construction of clutch or brake mechanism, or of application of blocks, but only to show in general how and where our blocks may be used.

### Description of Diagrams A, B and C

**Diagram A.**—Typical hoisting drum with brake and friction equipment. Lever throws friction block B, on revolving gear wheel, into contact with winding drum, transmitting power from gear to drum. When unwinding, drum is stopped by forcing iron band lined with brake blocks "A" against drum. Diagram A also shows asbestos blocks used as a facing on old wooden frictions. Facings are less expensive than complete V-shape blocks.

**Diagram B.**—Shows principle of simple cone clutch with Johns-Manville blocks used as facing. Power is transmitted from power to transmission shaft by forcing cone and facing into contact with fly-wheel. Pedal or lever controls cone.

**Diagram C.**—Shows elementary principles of multiple disc clutch or brake. Discs "A" are keyed to transmission shaft; discs "B" are held to fly-wheel by slots cut in edges which fit around bolts. Power is transmitted or absorbed by forcing discs "A" and "B" together by a spring. Pressure is released by forcing spring back from discs with lever.

DIAGRAM B

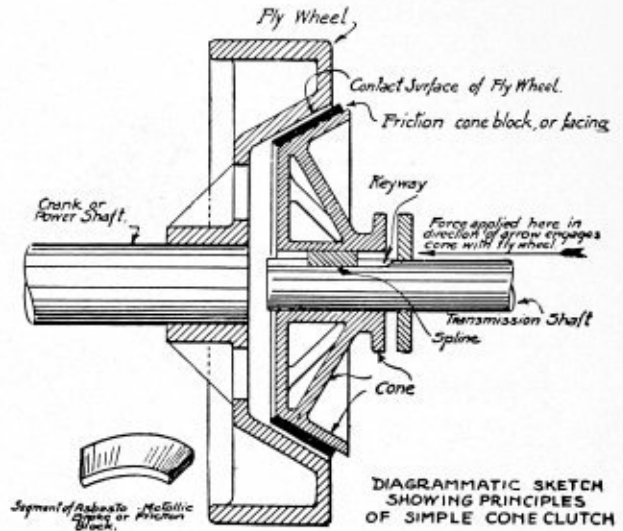

DIAGRAM C

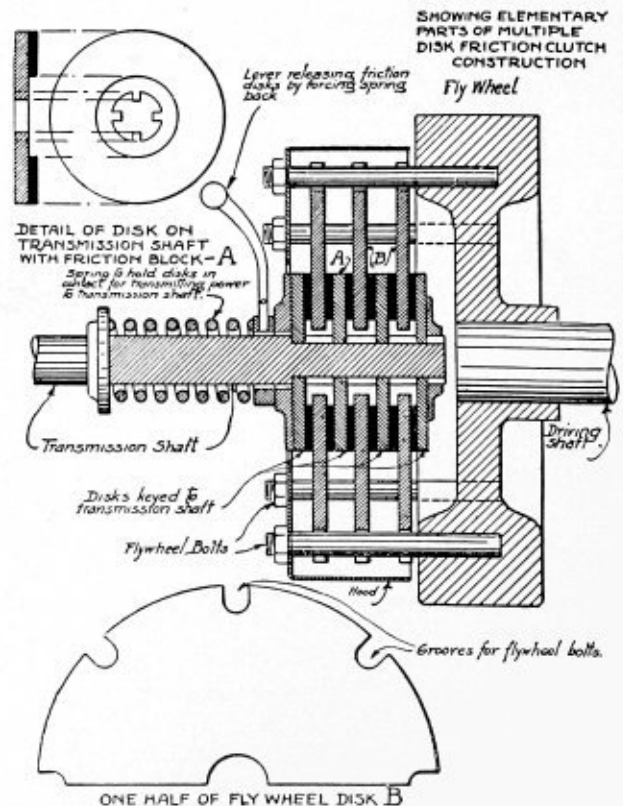
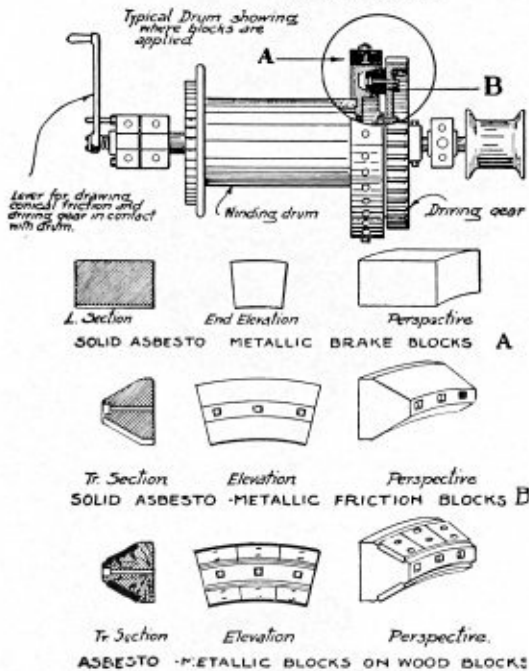

DIAGRAM A

HOISTING DRUM EQUIPPED WITH FRICTION AND BRAKE BLOCKS





# Johns-Manville Non-Burn Asbestos Brake Band Lining for Industrial Use

**W**HERE machine design prevents the use of blocks, we recommend Johns-Manville Non-Burn Asbestos Brake Band Lining.

Johns-Manville Non-Burn Brake Band Lining is made of asbestos fibre spun into yarn, reinforced with wires interwoven in each strand,



and impregnated with a compound which greatly increases its natural frictional and wearing qualities.

Most economical because it has high gripping power and great resistance to heat and foreign matter.

For details on asbestos brake band lining for automobiles, see page 234.

Every piece of Non-Burn is stencilled with the name—look for it.

## List Prices per linear foot

*Furnished in two styles—Woven and Folded*

NOTE.—The following list covers widths and thicknesses usually used for machinery purposes. Folded style can be furnished in all sizes listed. Woven style can be furnished in all widths listed, to and including  $\frac{5}{16}$ " in thickness.

Width	$\frac{3}{16}$ " Thick	$\frac{5}{16}$ " Thick	$\frac{3}{8}$ " Thick	$\frac{1}{2}$ " Thick	$\frac{5}{8}$ " Thick	$\frac{3}{4}$ " Thick	$\frac{7}{8}$ " Thick	$\frac{1}{2}$ " Thick	$\frac{3}{4}$ " Thick	$\frac{1}{2}$ " Thick	$\frac{3}{4}$ " Thick	$\frac{1}{2}$ " Thick
1 "	\$ .40	\$ .45	\$ .50	\$ .70	\$ .80	\$ .96	\$1.22	\$1.48	\$1.73	\$1.99	\$2.24	\$2.24
1 1/8 "	.50	.55	.60	.80	.94	1.16	1.48	1.80	2.12	2.44	2.76	2.76
1 1/4 "	.60	.65	.70	.90	1.11	1.35	1.73	2.12	2.50	2.88	3.27	3.27
1 3/4 "	.70	.75	.80	1.00	1.26	1.54	1.99	2.44	2.88	3.33	3.78	3.78
2 "	.80	.85	.90	1.20	1.41	1.73	2.24	2.76	3.27	3.78	4.29	4.29
2 1/8 "	.90	.95	1.00	1.30	1.56	1.92	2.50	3.08	3.65	4.23	4.80	4.80
2 1/4 "	1.00	1.05	1.10	1.50	1.72	2.12	2.76	3.40	4.04	4.68	5.32	5.32
2 3/4 "	1.10	1.15	1.20	1.60	1.87	2.31	3.01	3.72	4.42	5.12	5.83	5.83
3 "	1.20	1.25	1.30	1.70	2.02	2.50	3.27	4.04	4.80	5.57	6.34	6.34
3 1/4 "	1.25	1.35	1.40	1.80	2.16	2.69	3.52	4.36	5.19	6.02	6.85	6.85
3 1/2 "	1.30	1.45	1.50	1.90	2.21	2.88	3.78	4.68	5.57	6.47	7.36	7.36
3 3/4 "	1.35	1.50	1.60	2.05	2.31	3.08	4.04	5.00	5.96	6.92	7.88	7.88
4 "	1.40	1.55	1.70	2.20	2.50	3.27	4.29	5.32	6.38	7.36	8.39	8.39
4 1/4 "	1.73	1.85	1.97	2.37	2.71	3.46	4.55	5.64	6.72	7.81	8.90	8.90
4 1/2 "	1.80	1.94	2.08	2.50	2.92	3.65	4.80	5.96	7.11	8.26	9.41	9.41
4 3/4 "	1.86	2.03	2.19	2.63	3.07	3.84	5.06	6.28	7.49	8.71	9.92	9.92
5 "	1.92	2.11	2.29	2.70	3.22	4.04	5.32	6.60	7.88	9.16	10.44	10.44
5 1/4 "	2.02	2.21	2.40	2.88	3.36	4.23	5.57	6.92	8.26	9.60	10.95	10.95
5 1/2 "	2.12	2.31	2.50	3.01	3.52	4.42	5.83	7.24	8.64	10.05	11.46	11.46
5 3/4 "	2.21	2.40	2.60	3.14	3.67	4.61	6.08	7.56	9.03	10.50	11.97	11.97
6 "	2.27	2.49	2.71	3.27	3.82	4.80	6.34	7.88	9.41	10.95	12.48	12.48
6 1/4 "	2.64	2.90	3.15	3.80	4.44	5.00	6.60	8.20	9.80	11.40	13.00	13.00
6 1/2 "	2.72	3.03	3.34	3.94	4.61	5.19	6.85	8.52	10.18	11.84	13.51	13.51
6 3/4 "	2.79	3.09	3.40	4.08	4.78	5.38	7.11	8.84	10.56	12.29	14.02	14.02
7 "	2.86	3.18	3.49	4.20	4.95	5.57	7.36	9.16	10.95	12.69	14.53	14.53
7 1/4 "	2.97	3.31	3.65	4.37	5.12	5.76	7.62	9.48	11.33	13.19	15.04	15.04
7 1/2 "	3.08	3.44	3.80	4.52	5.28	5.96	7.88	9.80	11.72	13.64	15.56	15.56
7 3/4 "	3.15	3.51	3.87	4.66	5.46	6.15	8.13	10.12	12.10	14.08	16.07	16.07
8 "	3.22	3.59	3.96	4.80	5.63	6.34	8.39	10.44	12.48	14.53	16.58	16.58
8 1/4 "	3.33	3.72	4.10	4.95	5.80	6.53	8.64	10.76	12.87	14.98	17.09	17.09
8 1/2 "	3.44	3.80	4.23	5.09	5.96	6.72	8.90	11.08	13.25	15.43	17.60	17.60
8 3/4 "	3.51	3.93	4.28	5.24	6.13	6.92	9.16	11.40	13.64	15.88	18.12	18.12

(List Prices continued on next page.)



## List Prices per linear foot (continued)

*Furnished in two styles—Woven and Folded*

NOTE.—The following list covers widths and thicknesses usually used for machinery purposes. Folded style can be furnished in all sizes listed. Woven style can be furnished in all widths listed, to and including  $\frac{3}{16}$ " in thickness.

Width	$\frac{3}{16}$ " Thick	$\frac{5}{16}$ " Thick	$\frac{3}{8}$ " Thick	$\frac{7}{16}$ " Thick	$\frac{1}{2}$ " Thick	$\frac{5}{8}$ " Thick	$\frac{3}{4}$ " Thick	$\frac{7}{8}$ " Thick	$1\frac{1}{8}$ " Thick	$1\frac{1}{4}$ " Thick	$1\frac{3}{8}$ " Thick	$1\frac{1}{2}$ " Thick
9 "	\$3.58	\$4.00	\$4.43	\$5.38	\$6.30	\$7.11	\$9.41	\$11.72	\$14.02	\$16.32	\$18.63	\$18.63
9 $\frac{1}{4}$ "	3.69	4.13	4.57	5.52	6.47	7.30	9.67	12.04	14.40	16.77	19.14	19.14
9 $\frac{1}{2}$ "	3.80	4.26	4.72	5.67	6.64	7.49	9.92	12.36	14.79	17.22	19.65	19.65
9 $\frac{3}{4}$ "	3.87	4.36	4.86	5.81	6.81	7.68	10.18	12.68	15.17	17.67	20.16	20.16
10 "	3.94	4.42	4.90	5.96	6.98	7.88	10.44	13.00	15.56	18.12	20.68	20.68
10 $\frac{1}{4}$ "	4.05	4.53	5.02	6.10	7.15	8.07	10.69	13.32	15.94	18.56	21.19	21.19
10 $\frac{1}{2}$ "	4.16	4.64	5.13	6.24	7.32	8.26	10.95	13.64	16.32	19.01	21.70	21.70
10 $\frac{3}{4}$ "	4.23	4.74	5.24	6.39	7.48	8.45	11.20	13.96	16.71	19.46	22.21	22.21
11 "	4.30	4.84	5.36	6.53	7.65	8.64	11.46	14.28	17.09	19.91	22.72	22.72
11 $\frac{1}{4}$ "	4.41	4.95	5.49	6.68	7.83	8.84	11.72	14.60	17.48	20.36	23.24	23.24
11 $\frac{1}{2}$ "	4.52	5.06	5.61	6.82	8.00	9.03	11.97	14.92	17.86	20.80	23.75	23.75
11 $\frac{3}{4}$ "	4.59	5.16	5.74	6.96	8.16	9.22	12.23	15.24	18.24	21.25	24.26	24.26
12 "	4.66	5.24	5.84	7.11	8.33	9.41	12.48	15.56	18.63	21.70	24.77	24.77
12 $\frac{1}{4}$ "	4.76	5.36	5.96	7.25	8.50	9.60	12.74	15.88	19.01	22.15	25.28	25.28
12 $\frac{1}{2}$ "	4.85	5.46	6.07	7.40	8.68	9.80	13.00	16.20	19.40	22.60	25.80	25.80
12 $\frac{3}{4}$ "	4.96	5.57	6.19	7.54	8.84	9.99	13.25	16.52	19.78	23.04	26.31	26.31
13 "	5.06	5.68	6.31	7.68	9.02	10.18	13.51	16.84	20.16	23.49	26.82	26.82
13 $\frac{1}{4}$ "	5.15	5.79	6.43	7.83	9.19	10.37	13.76	17.16	20.55	23.94	27.33	27.33
13 $\frac{1}{2}$ "	5.25	5.89	6.54	7.97	9.36	10.56	14.02	17.48	20.93	24.39	27.84	27.84
13 $\frac{3}{4}$ "	5.35	6.00	6.66	8.12	9.53	10.76	14.28	17.80	21.32	24.84	28.36	28.36
14 "	5.45	6.11	6.78	8.26	9.70	10.95	14.53	18.12	21.70	25.28	28.87	28.87
14 $\frac{1}{4}$ "	5.55	6.22	6.90	8.40	9.87	11.14	14.79	18.44	22.08	25.73	29.38	29.38
14 $\frac{1}{2}$ "	5.64	6.33	7.02	8.55	10.04	11.33	15.04	18.76	22.47	26.18	29.89	29.89
14 $\frac{3}{4}$ "	5.75	6.44	7.14	8.69	10.21	11.52	15.30	19.08	22.85	26.63	30.40	30.40
15 "	5.85	6.56	7.26	8.84	10.39	11.72	15.56	19.40	23.24	27.08	30.92	30.92
15 $\frac{1}{4}$ "	5.94	6.66	7.37	8.98	10.54	11.91	15.81	19.72	23.62	27.52	31.43	31.43
15 $\frac{1}{2}$ "	6.04	6.76	7.48	9.12	10.72	12.10	16.07	20.04	24.00	27.97	31.94	31.94
15 $\frac{3}{4}$ "	6.14	6.87	7.60	9.27	10.90	12.29	16.32	20.36	24.39	28.42	32.45	32.45
16 "	6.24	6.97	7.71	9.41	11.07	12.48	16.58	20.68	24.77	28.87	32.96	32.96
16 $\frac{1}{4}$ "	6.33	7.08	7.83	9.56	11.24	12.68	16.84	21.00	25.16	29.32	33.48	33.48
16 $\frac{1}{2}$ "	6.43	7.19	7.95	9.70	11.40	12.87	17.09	21.32	25.54	29.76	33.99	33.99
16 $\frac{3}{4}$ "	6.52	7.29	8.08	9.84	11.56	13.06	17.35	21.64	25.92	30.21	34.50	34.50
17 "	6.60	7.40	8.20	9.99	11.73	13.25	17.60	21.96	26.31	30.66	35.01	35.01
17 $\frac{1}{4}$ "	6.70	7.51	8.32	10.13	11.90	13.44	17.86	22.28	26.69	31.11	35.52	35.52
17 $\frac{1}{2}$ "	6.80	7.61	8.45	10.28	12.07	13.64	18.12	22.60	27.08	31.56	35.78	35.78
17 $\frac{3}{4}$ "	6.90	7.72	8.55	10.42	12.24	13.83	18.37	22.92	27.46	32.00	36.55	36.55
18 "	7.00	7.83	8.67	10.56	12.40	14.02	18.63	23.24	27.84	32.45	37.06	37.06
18 $\frac{1}{4}$ "	7.08	7.93	8.78	10.71	12.57	14.21	18.88	23.56	28.23	32.90	37.57	37.57
18 $\frac{1}{2}$ "	7.16	8.03	8.88	10.85	12.74	14.40	19.14	23.88	28.61	33.35	38.08	38.08
18 $\frac{3}{4}$ "	7.24	8.12	9.01	11.00	12.92	14.60	19.40	24.20	29.00	33.80	38.60	38.60
19 "	7.32	8.23	9.13	11.14	13.08	14.79	19.65	24.52	29.38	34.24	39.11	39.11
19 $\frac{1}{4}$ "	7.41	8.33	9.25	11.28	13.25	14.98	19.91	24.84	29.76	34.60	39.62	39.62
19 $\frac{1}{2}$ "	7.51	8.43	9.36	11.43	13.44	15.17	20.16	25.16	30.15	35.14	40.13	40.13
19 $\frac{3}{4}$ "	7.60	8.53	9.48	11.57	13.60	15.36	20.42	25.48	30.53	35.59	40.64	40.64
20 "	7.68	8.64	9.60	11.72	13.76	15.56	20.68	25.80	30.92	36.06	41.16	41.16
20 $\frac{1}{4}$ "	7.77	8.74	9.72	11.86	13.93	15.75	20.93	26.12	31.30	36.48	41.67	41.67
20 $\frac{1}{2}$ "	7.87	8.84	9.83	12.00	14.10	15.94	21.19	26.44	31.68	36.93	42.18	42.18
20 $\frac{3}{4}$ "	7.96	8.95	9.94	12.15	14.27	16.13	21.44	26.76	32.07	37.38	42.69	42.69
21 "	8.04	9.06	10.07	12.29	14.44	16.32	21.70	27.08	32.45	37.83	43.20	43.20
21 $\frac{1}{4}$ "	8.13	9.16	10.19	12.44	14.60	16.52	21.96	27.40	32.84	38.28	43.72	43.72
21 $\frac{1}{2}$ "	8.23	9.26	10.30	12.58	14.78	16.71	22.21	27.72	33.22	38.72	44.23	44.23
21 $\frac{3}{4}$ "	8.32	9.36	10.43	12.72	14.95	16.90	22.47	28.04	33.60	39.17	44.74	44.74
22 "	8.40	9.47	10.53	12.87	15.12	17.09	22.72	28.36	33.99	39.62	45.25	45.25
22 $\frac{1}{4}$ "	8.49	9.57	10.65	13.01	15.28	17.28	22.98	28.68	34.37	40.07	45.76	45.76
22 $\frac{1}{2}$ "	8.59	9.68	10.77	13.16	15.46	17.48	23.24	29.00	34.76	40.52	46.28	46.28
22 $\frac{3}{4}$ "	8.68	9.78	10.88	13.30	15.62	17.67	23.49	29.32	35.14	40.96	46.79	46.79
23 "	8.76	9.88	11.00	13.44	15.79	17.86	23.75	29.64	35.52	41.41	47.30	47.30
23 $\frac{1}{4}$ "	8.85	9.99	11.12	13.59	15.96	18.05	24.00	29.96	35.91	41.86	47.81	47.81
23 $\frac{1}{2}$ "	8.95	10.09	11.25	13.73	16.13	18.24	24.24	30.28	36.29	42.31	48.32	48.32
23 $\frac{3}{4}$ "	9.04	10.20	11.36	13.88	16.30	18.44	24.52	30.60	36.68	42.76	48.84	48.84
24 "	9.12	10.30	11.47	14.02	16.47	18.63	24.77	30.92	37.06	43.20	49.35	49.35



# Johns-Manville Steam Traps

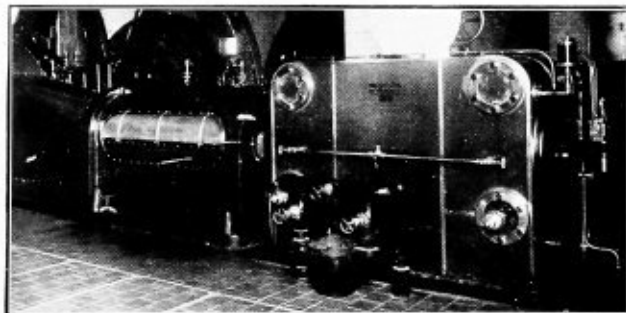

## The Johns-Manville Steam Trap

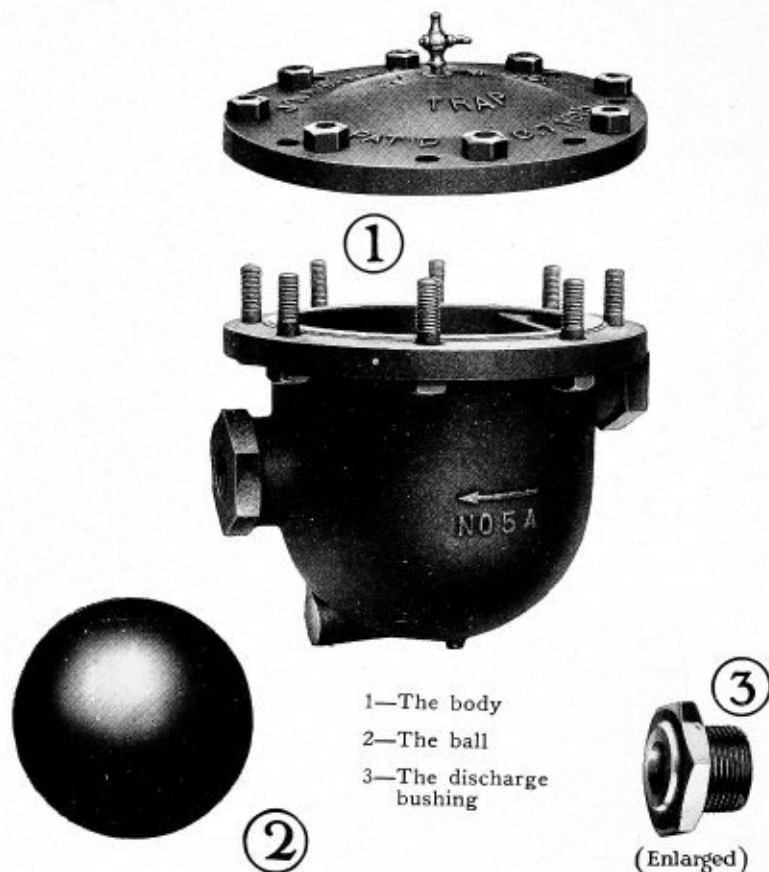

1—The body  
2—The ball  
3—The discharge  
bushing

(Enlarged)

**O**WNERS, superintendents and engineers give the purchase of large units for their power or heating plants the most careful consideration, but the importance of the smaller and less expensive power-plant unit is often overlooked.

For example: The economical operation of a plant is largely dependent upon the efficiency of the steam trap used.

The little device that guards the outlet of the coil or radiator, that should prevent any steam from getting away before it has given up its heat and yet allow *all* water and air to get away and make room for more steam, is an important factor of the heating system.

See table showing loss due to steam leakage, page 247, Appendix.

### Continuous Perfect Operation

of a trap necessarily depends upon the design of the trap and the arrangement of its parts. The Johns-Manville Trap has only three parts—the body, the discharge bushing, which screws into the outlet of the body, and the hollow, seamless copper

ball, which is free to float and move in the body.

Wear and maintenance cost naturally depend upon the number of trap parts—especially those that move or those that are subject to corrosion.



## ACTION OF THE JOHNS-MANVILLE TRAP

When water first flows into the trap at X and begins flowing out of the discharge orifice Y, the ball (2) floats to and is held against the discharge bushing (3) by an unbalanced steam pressure.

The discharge orifice is completely sealed until the water level W in the trap begins to rise, then the buoyant force of the water rolls the ball upwards on the face of the discharge bushing (3), exposing either part or the entire area of the discharge orifice Y—depending upon the quantity of water entering the trap at X.

When the quantity of water entering the trap at X decreases, the level of the water drops to the point where the ball again partially or completely covers the discharge orifice Y being held tightly against the face of the bushing (3) by the unbalanced steam pressure. In this way a water seal is provided between the steam in the top of the trap and the discharge orifice Y, eliminating all possibility of steam leakage.

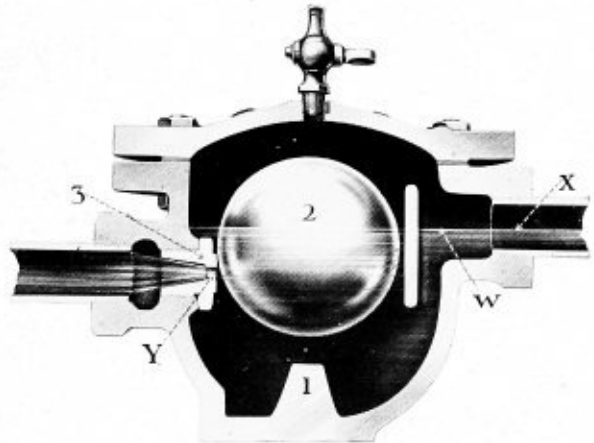

The one moving part of the Johns-Manville Trap, the *ball*—replaces the valve, valve stem, levers, cotter pins, springs, thermostatic parts, buckets and all other similar parts used in the construction of other types of steam traps.

The operation of the Johns-Manville Trap is positive and simple. It depends entirely upon the amount of water flowing to the trap.

The ball is held against the flat surface

of the discharge bushing by the pressure in the system.

Water flowing into the trap acts as a force which raises or rolls the ball upward on the face of the discharge bushing and thus exposes part or all of the outlet orifice. The ball rises and falls, according to the quantity of condensation coming to the trap, and the flow from the trap is regulated accordingly.

## No Air Binding

The Johns-Manville Trap will not air bind because air (heavier than steam but lighter than water) accumulates on the surface of the water, which is a very short distance above the trap outlet and is discharged with the water through small vortices that form between the surface of the water and the outlet. We put a pet cock on the cover of our trap, not as an air relief, but because it is useful to show that the trap is operating properly.

If a trap will not discharge air or gas as well as water, the air will accumulate in the trap and system unless vented by some supplementary means. The inability of other types of steam traps to discharge air *with the water and without loss of steam* is due to their construction and principle of operation requiring a thick water seal over the outlet of the trap to prevent the loss of steam. Such a water seal effectually prevents the discharge of air.

## No Steam Leakage

is possible with the Johns - Manville Trap because there is always a thin water seal between the outlet and the steam. If the water-level drops too near the outlet

the ball also floats lower, closes the outlet and effectively stops discharge of water or steam.



## The Johns-Manville Steam Trap

on account of its simplicity of construction and operation, requires practically no attention.

There are no adjustments to make—no valves to stick. Replacements or repairs seldom have to be made. In fact, there are only two parts — the ball and discharge bushing—that could wear.

Operation is positive and continuous, hence any machine or system to which these traps are attached is always free of air and water.

The Regular Models (made of cast iron) are suitable for all pressures. The Junior Models are made for pressures up to fifty pounds per square inch.

### Capacity and Dimensions

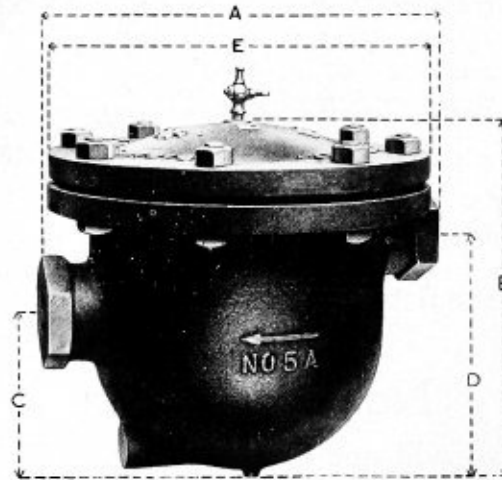

See table for dimensions indicated

The capacities given for pipe sizes shown are average, *not the maximum*—as are frequently given in other capacity tables. Peak or emergency conditions frequently require a trap to handle more water

than when operating under normal conditions so a factor of safety should be allowed. The Johns-Manville Trap will take care of more water than any other trap of the same size.

#### CAST IRON MODELS FOR ANY PRESSURE

Trap No.	Pipe Size, Ins.	Lbs. of Water Per Hour	Dimensions in inches. (See diagram.)					Weight Lbs.	List Price Each
			A	B	C	D	E		
2-A.....	$\frac{3}{4}$	700	$7\frac{5}{16}$	6	$2\frac{7}{8}$	$3\frac{3}{4}$	$6\frac{3}{4}$	$14\frac{1}{4}$	\$27.00
3-A.....	1	1000	$8\frac{1}{4}$	$7\frac{1}{8}$	$3\frac{1}{2}$	$4\frac{1}{2}$	8	23	35.00
4-A.....	$1\frac{1}{4}$	1700	$10\frac{7}{8}$	$8\frac{3}{4}$	$4\frac{3}{8}$	$5\frac{1}{4}$	$10\frac{1}{4}$	47	40.00
5-A.....	$1\frac{1}{2}$	3500	$12\frac{3}{4}$	$11\frac{1}{4}$	$5\frac{5}{8}$	$7\frac{1}{2}$	$12\frac{1}{2}$	85	70.00
6-A.....	2	6000	$14\frac{1}{2}$	13	$6\frac{5}{8}$	$8\frac{1}{8}$	$14\frac{1}{4}$	126	95.00





## The Johns-Manville Junior Trap

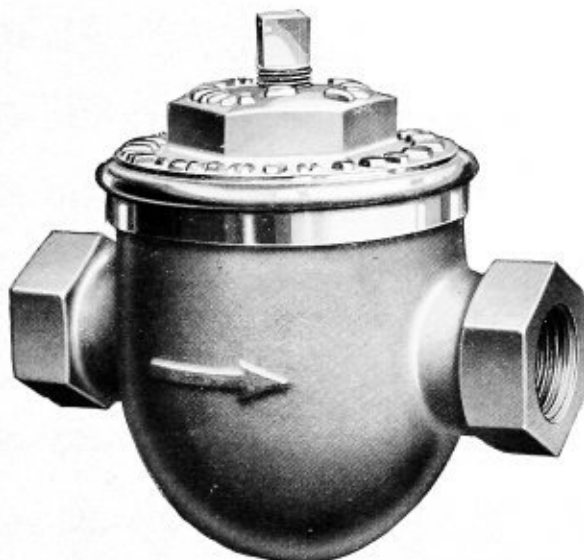

A compact trap for low, medium or high pressure services.

**I**DEAL for small steam line drips, coils, indirect stacks, radiators, cooking-utensils, coffee-urns, plate-warmers, steam-tables, sterilizers, ovens, kettles, glue-pots, steam-plates, laundry machines, dryers, dressers, calenders, etc., or wherever condensation does not exceed 250 pounds per hour and the steam pressure is not over 50 lbs. per square inch.

The Johns-Manville Junior Trap is the same in its principle of operation as the larger Johns-Manville Trap, the only difference being its size, the metal of which the body is made, and the fact that the

cover screws to the body instead of being bolted. This makes it extremely compact.

The Junior, too, consists of only a body rolling ball and discharge bushing. Discharges continuously; will not leak steam; has no complicated parts and *cannot air-bind*.

Johns-Manville Junior Steam Traps are equipped with bushings for low and medium pressures. Neatly finished, made of highest grade steam metal. Pressure ranges are 1 to 10 lbs.; 10 to 50 lbs.; see tabulation below:

### BRONZE JUNIOR MODELS FOR PRESSURES UP TO 50 POUNDS

Trap with bushings for	Pressure Range	Pipe Size Inches	Dimensions	Weight	Each List Price
Low Medium pressures	1-10 lbs. } 10-50 lbs. }	1/2	4 1/4" long x 3 5/8" high	2 3/8 lbs.	\$10.00



## The Johns-Manville Radiator Trap

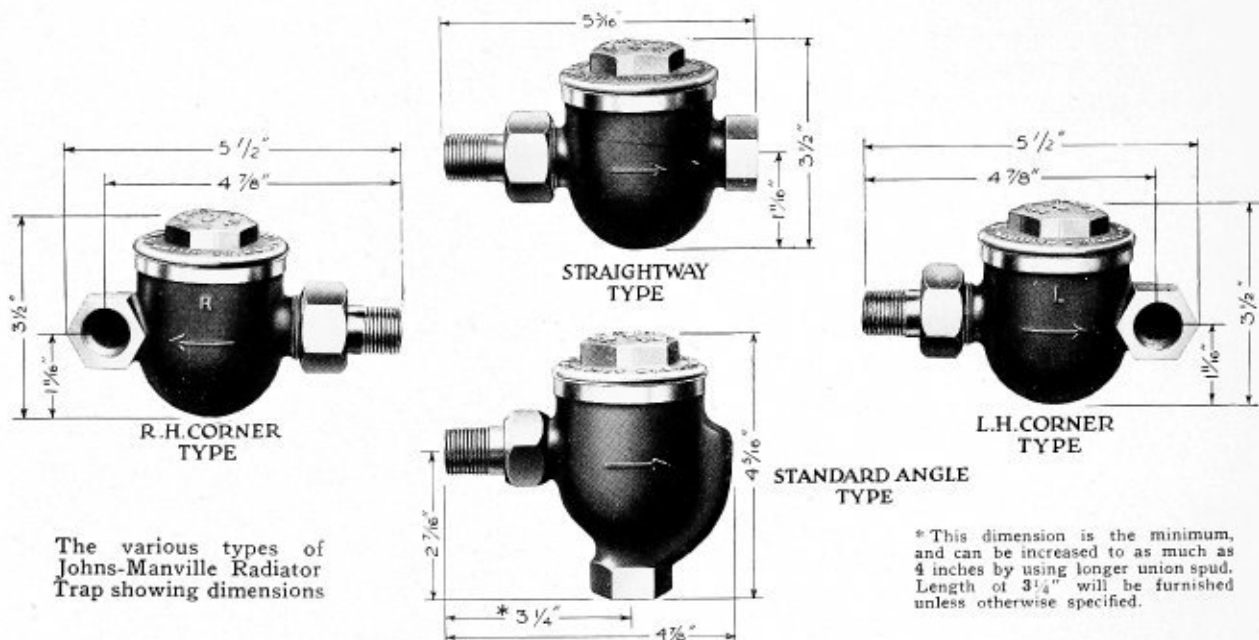

The various types of Johns-Manville Radiator Trap showing dimensions

**T**HE Johns-Manville Radiator Trap operates on exactly the same principle as the Johns-Manville Steam Trap. The only part that moves is the ball—it discharges air, gas and water continuously as they come to it and without loss of steam. *The action of the Johns-Manville Radiator Trap is positive*—that is, it is operated *directly* by the water of condensation which must be discharged from the radiator, and not indirectly by the temperature of the water to be discharged. Those qualities which make it superior, and so desirable to use with heating systems are:

*Simplicity*—Nothing to get out of order.

*Durability*—Nothing to wear — repairs and replacements minimized.

*Non-Adjustable* — Nothing to adjust—therefore no after adjustments necessary and no chance of adjustments being tampered with.

*Noiseless*—Nothing to vibrate, rattle or make any kind of noise, as the ball is the only moving part and is surrounded by a cushion of water.

*No Steam Leakage*—A thin but constant water seal always prevents steam leakage.

*Non-Air Binding*—Free discharge of air and water permits radiators to heat up rapidly.

*Capacity*—Not affected by variation in temperature of water discharged.

*Finished Appearance*—The shape and size make the Johns-Manville Trap an attractive part of the heating system.

The owner, architect, engineer and operator will get full satisfaction because after installation perfect results are obtained without care or changes.

Steam-fitters and contractors will be relieved of all trouble after installation because of no after adjustments and a minimum of repairs and replacements.



For pressures up to 10 pounds—either atmospheric or vacuum return line systems. Furnished in bronze or bronze with

plain nickel finish. For use on cast iron radiators only, unless ordered special. For dimensions, see page 98.

SPECIFICATIONS AND LIST PRICES FOR JOHNS-MANVILLE RADIATOR TRAPS

Trap	Connections	Pressure Range	Pipe Size Inches	Approximate Weight	Finish	List Price Each
Standard Angle Type	1/2" and 3/4"	0 to 10 pounds	1/2"	2 lbs. 5 oz. bronze	.....	\$7.00
			1/2"	2 lbs. 5 oz. nickel finish	...	7.50
			3/4"	2 lbs. 7 oz. bronze	.....	8.00
			3/4"	2 lbs. 7 oz. nickel finish	...	8.50
Straightway Type	1/2" and 3/4"	0 to 10 pounds	1/2"	2 lbs. 3 oz. bronze	.....	8.00
			1/2"	2 lbs. 3 oz. nickel finish	...	8.50
			3/4"	2 lbs. 6 oz. bronze	.....	9.00
			3/4"	2 lbs. 6 oz. nickel finish	...	9.50
Corner Type (Right and left)	1/2" only	0 to 10 pounds	1/2"	2 lbs. 4 oz. bronze	.....	8.00
			1/2"	2 lbs. 4 oz. nickel finish	...	8.50

## How to specify a Johns-Manville Steam Trap

**A**LL steam traps required shall be suitable for pressures at which they must operate, and must discharge air as well as water without the aid of separate air passages. All traps are to be of the non-attached rolling ball type, consisting of only three essential parts: body, non-attached rolling ball and discharge

bushing. The hollow copper ball is to act as a valve to regulate the discharge from the trap, and is to be free to revolve or move in any direction, having no levers, rods, weights or valves of any description attached to it. The traps are to contain no thermostatic parts.

## How to specify a Johns-Manville Radiator Trap

All radiator traps placed on the return side of the radiators shall have 1/2" connections and must discharge air as well as water without the aid of separate air passages. All traps shall be of the non-attached rolling ball type, consisting of only three essential parts, the body, non-attached rolling ball, and a union connection. The hollow copper ball which acts as a valve to regulate the discharge from the trap is to be the only moving part and is to be free to revolve or move in any direction, having no levers, rods, weights or valves of any description attached to it.

The radiator traps are to contain no thermostatic parts.

No other valve will be accepted under this specification unless approved by the Architect in writing.

### NOTE

If it is desired to specify Johns-Manville traps by their names, an additional paragraph should precede the other paragraphs on both steam and radiator trap specifications. This paragraph to read: "All traps shall be the Johns-Manville non-attached rolling ball type."



## The Johns-Manville Volume Meter

*For the accurate measurement of  
boiler feed water, and other liquids*

**T**HE notable features of this meter are its extreme accuracy, simplicity and durability.

Constant accuracy and long life are secured by the total elimination of friction between meter parts. The meter has no moving parts. It cannot wear out.

Although originally designed for the measurement of boiler feed water its freedom from moving parts makes it ideally suited for the measurement of many liquids such as corrosive chemicals which prohibit the use of submerged bearings, valves or other mechanical parts.

As the meter is a purely static device and measures in fixed volumes it is equally well suited to the metering of liquids of varying viscosities and densities. It will accurately meter the volume of practically any liquid that will flow freely through a pipe or conduit.

The Johns-Manville Volume Meter consists essentially of two tanks or compartments of fixed volumetric capacity which are alternately filled and emptied. A

counter or chart recorder indicates the number of times the compartments are filled and emptied, thereby furnishing a record of the quantity of liquid passed through the meter.

The Johns-Manville Volume Meter can be built for any capacity from laboratory size up to that required for measuring a city water supply. Its accuracy is practically 100%.

In boiler plants the meter is particularly adaptable for such services as the measurement of boiler feed water, make-up water, wastes from hot wells and blow-off

tanks, or for the metering of condensate from power generating units.

Additional information will be furnished by any Johns-Manville Branch.

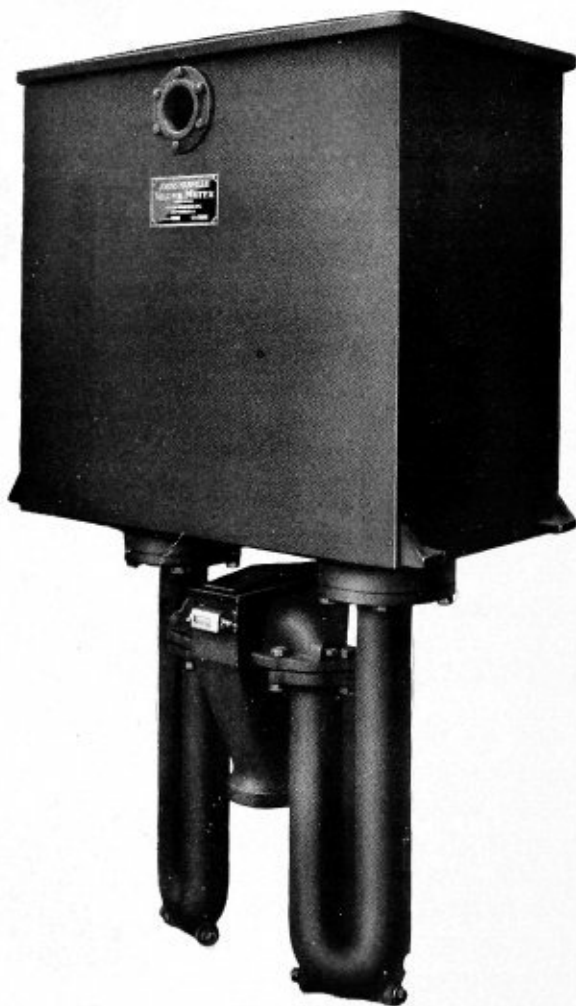



# Johns-Manville Asbestos Roofings



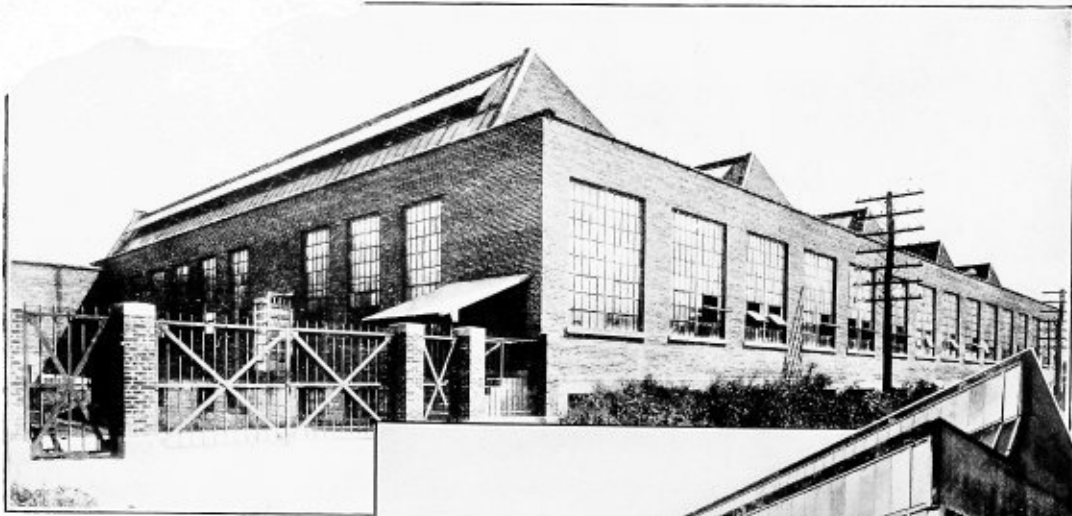

Two modern industrial buildings of the Willys-Morrow Co., Elmira, N. Y., protected by Johns-Manville Asbestos Built-Up Roofing. Mills, Rhines, Bellman and Nordhoff, Designing Engineers, Toledo, Ohio.



## Johns-Manville Asbestos Roofing

**T**HE quality of asbestos products depends not only upon the experience, skill and equipment of the manufacturer, but also upon the quality of the raw material. Since asbestos fibres vary, the correct grading and selection is absolutely necessary.

Controlling every step from mine to market, combining the facilities of the miner with the expert knowledge of the manufacturer, Johns-Manville has exceptional opportunities for discriminating in the selection of asbestos fibre for Johns-Manville Asbestos Roofings.

This is a distinct advantage to the user as it assures the highest standard of quality in the finished products.

The fibres extracted from the crushed asbestos rock are graded by length and strength. For roofing fabrics we select that grade of fibres which gives uniformity of texture and the highest tensile strength. For built-up and ready-to-lay roofing these fibres are fabricated by special machinery into strong compact felts, which in turn are thoroughly impregnated with natural asphalts. The felts are then cemented together with hot asphalt either on the roof (for built-up roofing) or at the factory (for ready-to-lay roofing).

There is no roof built—flat, monitor, saw-tooth, or special design—to which Johns-Manville Asbestos Roofing in one form or another cannot be applied.



## Approval by the Underwriters

**T**HE attitude of insurance authorities toward a building material is of special interest, both because of its effect on insurance rates, and because it serves as a reliable index to the fire-resistant properties of the material in question. For this reason the results of tests made by Underwriters' Laboratories, Inc., are of particular importance to the prospective buyer of any building material.

The Underwriters' Laboratories are located at Chicago, Ill., and are financed by

and maintained under the direction of the National Board of Fire Underwriters, the official body representing all recognized fire insurance companies of the country.

At these laboratories, roof coverings of every description are tested, examined and classified according to their resistance to fire. The tests made upon these roofings are most severe and exhaustive, including the radiant heat, burning brand and flame exposure tests described and illustrated on this and the following pages.



FIG. 1—MAKING RADIANT HEAT TEST

The temperature of the circular plate at the lowest point of the gas furnace is approximately 1200 degrees Fahrenheit. See page 107 for details of test.

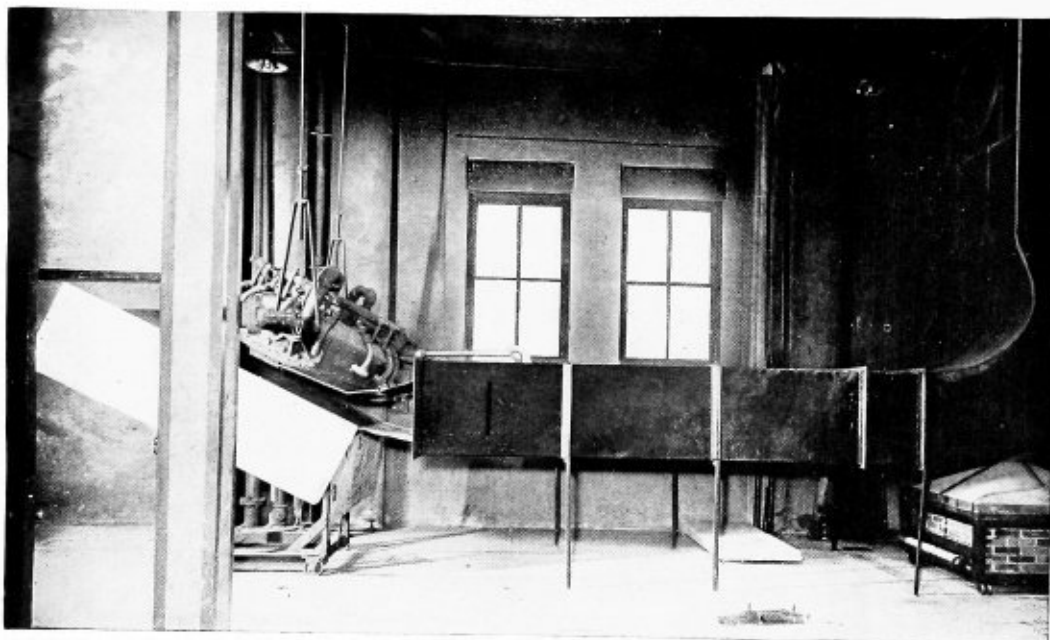

**FIG. 2—APPARATUS USED IN MAKING STANDARD FIRE TESTS OF ROOF COVERINGS**

The cylindrical gas furnace is mounted on trunnions so it can be turned to any angle at which the roofing is tested. The air duct is of sheet metal and has a discharge opening 7 by 2½ feet.

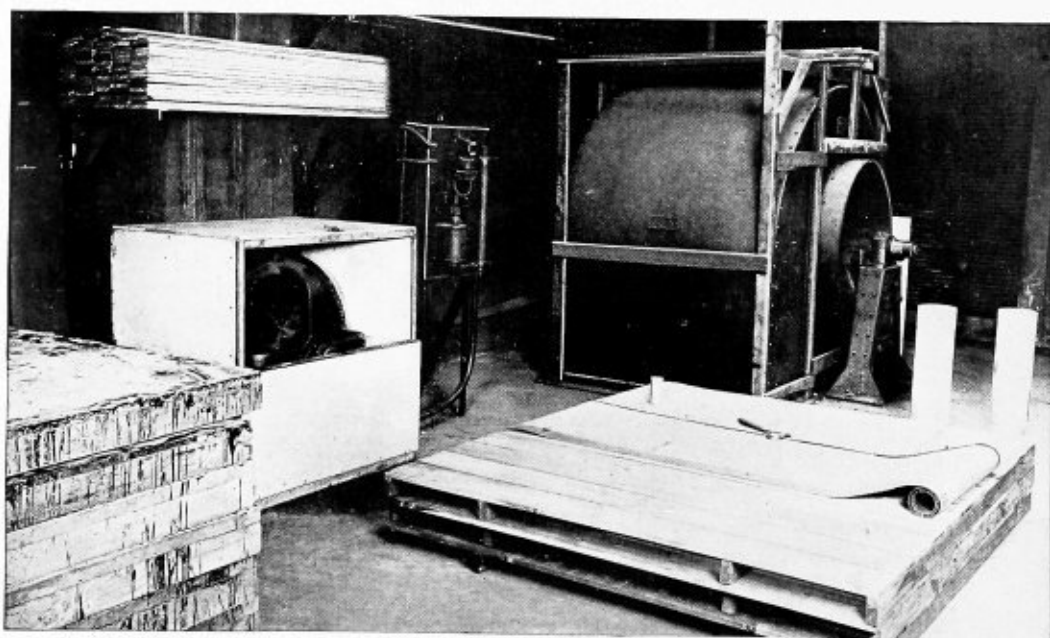

**FIG. 3—APPLYING SAMPLE ROOFING TO STANDARD DECKS FOR TESTS**

Experienced men are employed to do this work. A pile of completed decks is shown at the left. The motor and fan for securing the wind velocities are shown in the background.





## Burning Brand Test

SAMPLE SUBJECTED TO AIR CURRENTS OF 12 MILES PER HOUR



Exposed Side.



Unexposed Side.

SAMPLE SUBJECTED TO AIR CURRENTS OF 40 MILES PER HOUR



Exposed Side.



Unexposed Side.

Figure 4

Fig. 4—Photograph at top of page on left shows condition of Johns-Manville Asbestos Roofing after burning brand test; photograph on right shows under side of sheathing after same test. Wind velocity 12 miles per hour.

Photograph at bottom on left shows condition of Johns-Manville Asbestos Roofing after burning brand test with wind velocity of 40 miles per hour; photograph on right shows under side of sheathing after same test. See page 108 for details of test.



## Flame Exposure Test

SAMPLE SUBJECTED TO AIR CURRENTS OF 12 MILES PER HOUR

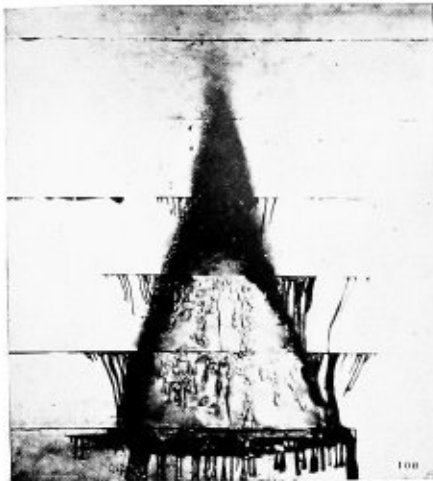

Exposed Side.



Unexposed Side.

SAMPLE SUBJECTED TO AIR CURRENTS OF 40 MILES PER HOUR

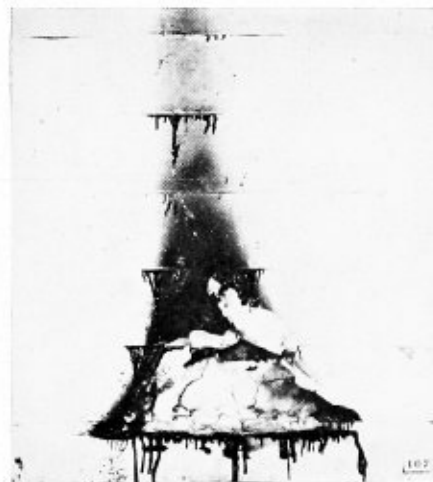

Exposed Side.

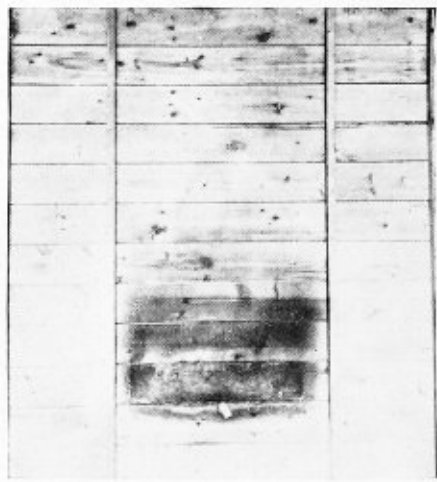

Unexposed Side.

Figure 5

Fig. 5—Photograph at top on left shows condition of Johns-Manville Asbestos Roofing after flame exposure test, subjected to air currents of 12 miles per hour; photograph on right shows under side of sheathing after test.

Photograph at bottom, on left, shows

condition of Johns-Manville Asbestos Roofing after flame exposure test, subjected to air currents of 40 miles per hour; photograph on right shows under side of sheathing after completion of same test. See page 109 for details of test.



## Radiant Heat Test

SAMPLE SUBJECTED TO AIR CURRENTS OF 12 MILES PER HOUR



Exposed Side.



Unexposed Side.

The illustrations on the left show condition of sample subjected to air currents of 12 miles per hour.

SAMPLE SUBJECTED TO AIR CURRENTS OF 40 MILES PER HOUR

The illustrations on the right show condition of sample subjected to air currents of 40 miles per hour.



Exposed Side.



Unexposed Side.

### Figure 6

Fig. 6—The photographs above show the condition of the Johns-Manville Asbestos Roofing and under side of sheathing after the radiant heat test was completed. In the radiant heat tests wind velocities of 12 miles per hour and 40 miles per hour are used to determine the effect upon the roofing material under examination. See page 108 for details of this test.

Seldom does a roofing on an average building encounter such conditions as it is called upon to withstand under the searching eyes of the impartial official investigators at the Underwriters' Laboratories; so that any roofing which meets these rigid laboratory requirements and is classified to take the base rate of insurance, may be safely put on any building with a

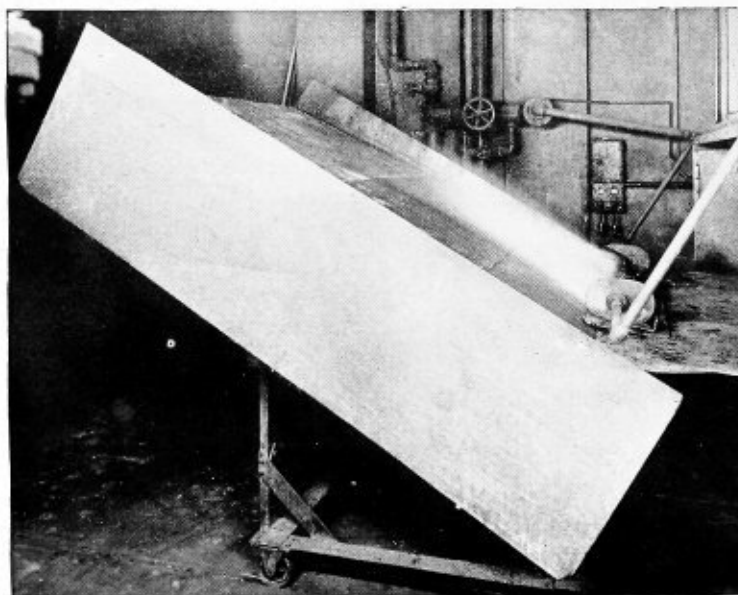

Fig. 7—Flame Exposure Test Apparatus in Action. See pages 106 and 109 for details.

knowledge that it is fire-safe to the highest degree.

Johns-Manville Asbestos Roofings are put through the tests described and are given either Class "A" or "B" rating,

according to the construction of the roof deck and the type of roofing. Either Class "A" or Class "B" takes the base rate of insurance.

## Radiant Heat Test

To determine how the roofing will stand up when subjected to the radiant heat from a nearby fire fanned by a breeze, a radiant heat test is made on the roofing while it is exposed to varying air currents

to simulate wind. A sample of roofing is shown undergoing such a test in Fig. 1, page 103. The results of this test are shown in Fig. 6, page 107.

## Burning Brand Test

To determine the fire resistance of a roofing when burning brands fall upon it, as is liable to happen to adjacent buildings when fire breaks out while a strong wind is blowing, each roofing examined at the Underwriters' Laboratories is subjected to the burning brand test.

In performing this test the burning brand is made up of 1" by 1" maple strips formed into a grid, the strips being approximately  $\frac{1}{4}$ " apart and held together

by similar strips to which they are nailed. The brand is approximately one foot square and is ignited by placing it in a gas furnace. This furnace is heated by a grill of gas jets which form the bottom of the furnace chamber.

The brand is supported above the jets and is exposed to the heat of the furnace until it is all aglow and completely covered with coals. The glowing brand is then lifted from the furnace and placed in





the proper position on the surface of the roofing sample. The brand is permitted to burn until entirely consumed or until the roof covering has failed by permitting the ignition of the deck boards on the under side. One operator carefully notes the time of ignition and the spread of flames

on the surface of the covering, also the rate at which the brand is consumed. Another operator observes the condition of the sample on the under side.

Fig. 4, page 105, shows the condition of Johns-Manville Asbestos Roofing and the under side of sheathing after this test.

### Flame Exposure Test

To observe the behavior of roofing under the action of flame playing directly upon it as might occur on a building roof, a direct flame contact test is made.

The apparatus used in subjecting samples of roof covering to direct flame contact is illustrated in Fig. 7, page 108. This apparatus consists of a burner with an orifice 36 inches long and  $\frac{1}{2}$  inch wide from which a gas flame is emitted. The flame passes over the surface of the sample directly exposing an area about 36 inches wide by 36 inches high.

The sample is set in place before the apparatus and the burner is ignited. The sample is thus exposed until the covering

fails and the deck boards are ignited. One operator observes the time of ignition of the covering and the rate of spread of flame over the surface while another operator observes the under side of the deck and notes the time in which the deck boards take fire. The effects of such a test on Johns-Manville Asbestos Roofing are evidenced in Fig. 5, page 106.

As a result of the extremely high fire resistance afforded by Johns-Manville Asbestos Roofings under these tests they have been given highest ratings—Class "A" or "B," according to roof deck and type of construction and take base rates of insurance.

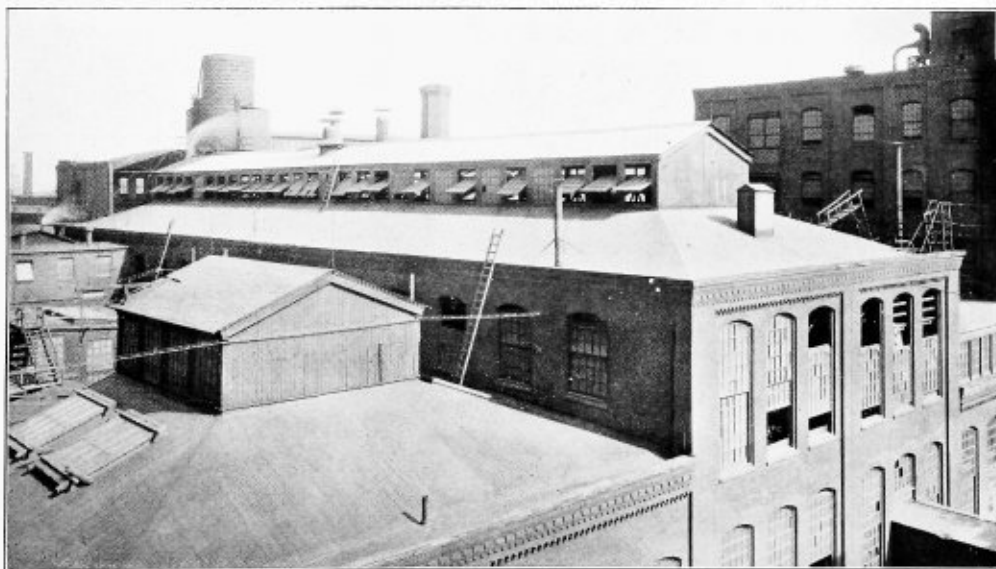

These buildings of the Baldwin Locomotive Works at Philadelphia, Pa., are permanently weatherproofed and fireproofed with Johns-Manville Asbestos Shingles.



## Johns-Manville Roof Registration

And What It Means to the User

**REGISTER THIS ROOFING**  
**WITH OUR NEAREST BRANCH**

*This enables us to identify the roof and give you full service  
Call in this blank and send to nearest branch  
C. O.*

*I purchased from \_\_\_\_\_  
squares of \_\_\_\_\_ Roofing which was  
applied \_\_\_\_\_ on building located at  
by \_\_\_\_\_*

**JOHNS-MANVILLE INC.**  
EXECUTIVE OFFICES: NEW YORK

CANADIAN JOHNS-MANVILLE CO., LTD.

A fac-simile reproduction of the Johns-Manville Roof Registration blank.

**I**N addition to a formal written guarantee for a specified number of years, which is the usual manner in which a roofing manufacturer vouches for the service value of his material, Johns-Manville offers a still broader protection through its plan of roof registration.

Under this plan a Johns-Manville roofing user registers his roofing with us, at the time of application, by filling in a registration blank as shown on this page and forwarding it to our nearest branch. This blank is recorded and placed in the hands of our roofing department which arranges for a periodical inspection of your roofing by a Johns-Manville representative.

This means that we keep careful track of the roofing in service, and notify you of the results of our inspection and of any

accidents, abuses or unusual condition existing at the time.

In this way we assume the entire responsibility for the performance of our materials and see that every Johns-Manville roof owner obtains the full service from his roofing that we promised for it. And this applies to every part of his roofing because we believe it is our duty to see that our materials in the flashings and gutters stand up as well as the surface of the roofing itself.

By this policy of roof registration we translate the formal terms of our guarantee into active service value to you.

Be sure that when a Johns-Manville Roof is applied to your building a registration blank is filled out and forwarded to us so that you will obtain the benefits of this service.

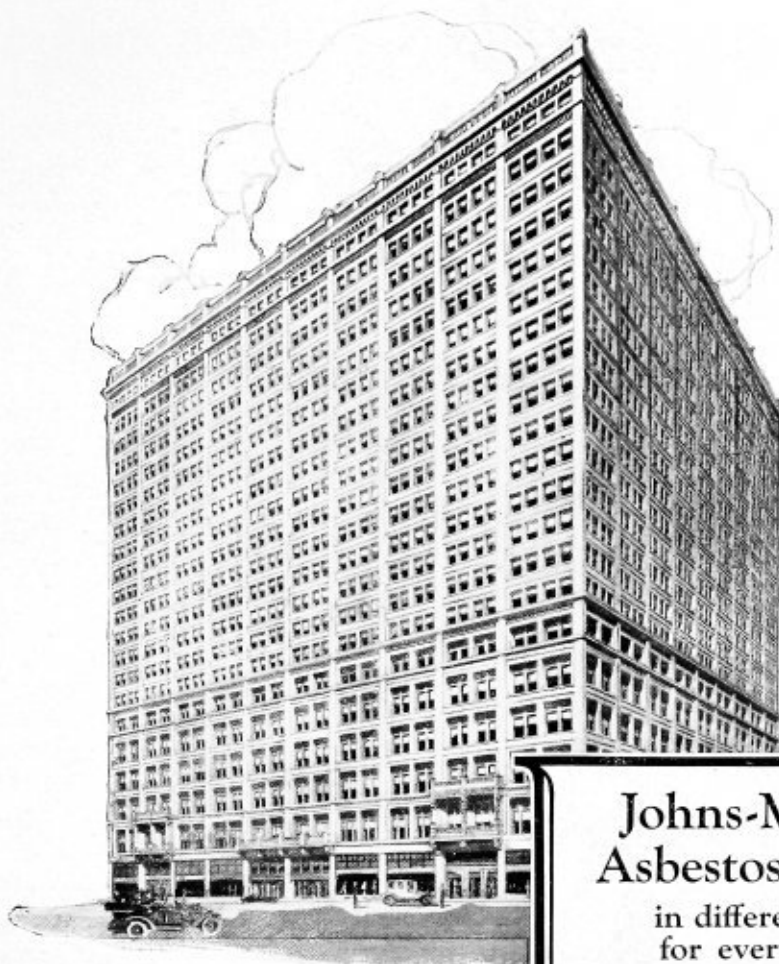

RAILWAY EXCHANGE BUILDING,  
ST. LOUIS, MO.,

Covered with Johns-Manville  
Asbestos Built-up Roofing.  
Mauran, Russell and Crowell,  
Architects, St. Louis

## Johns-Manville Asbestos Roofings

in different forms;  
for every type of  
service:

	Page
Asbestos Protected Metal Roofing and Siding . . . .	141
Built-up Asbestos Roofing	112
Corrugated Roofing and Siding, Transite . . . . .	133
Ready-to-lay Roofing, As- bestos, smooth and slate surfaced . . . . .	125
Ready-to-lay roofing, rag- felt, smooth and slate surfaced . . . . .	165
Shingles, Asbestos (Rigid type) . . . . .	149
Shingles, Asbestos, (slate surfaced, flexible type).	161
Shingles, Rag-Felt, slate surfaced . . . . .	166



A massive group of buildings of the Goodyear Tire & Rubber Co., Los Angeles, Calif., for which Johns-Manville Asbestos Built-up Roofing was chosen because, being made of rock, it assures maximum satisfactory service

## Johns-Manville Standard Asbestos Built-up Roofing

**F**OR flat or pitched decks up to 6" to the foot. Johns-Manville Standard Asbestos Built-up Roofing can also be laid on pitches exceeding 6" to the foot where suitable nailing is provided.

As a roofing cannot be better than the materials of which it is made, it is of first importance to know the nature and properties of the raw materials used to produce it. If such raw materials are inherently perishable or inflammable it would naturally follow that the finished roofing would have the same limitations.

Realizing that a durable roofing must be made of raw materials that are *naturally durable*, Johns-Manville uses Asbestos felts and natural asphalts—two minerals intended by nature for permanent water and weather protection.

Therefore, Johns-Manville Standard Asbestos Built-up Roofing, composed of these two minerals—is different and naturally affords longer and more economical service than roofings made of perishable materials.

*Its Main Points of Difference and Superiority Are:*

### It Is More Durable

It will last indefinitely because it is made of rock. There is nothing in it to rot or dry out. Asbestos, of which it is made, is a mineral that is practically as old as life

on earth; a mineral that has resisted the destructive forces of nature for centuries and is immune to rot and weather.





## It is More Economical

because it does not require painting, coating or surfacing of any kind after its installation. The reason it does not require this form of maintenance is that the asbestos felts retain their asphalt impregnation and do not dry out. As compared to rag felt roofings, which do require such expen-

sive upkeep, the elimination of this item with Johns-Manville Standard Asbestos Built-up Roofing represents a considerable and increasing saving, particularly where the roof area is large and service conditions severe enough to compel frequent maintenance of other roofings.

## Its Asbestos Felts

are waterproofed and built up on the roof deck with refined natural asphalts, the conceded best of all roofing and waterproofing agents. No coal tar pitch is used in the manufacture or application of Johns-Manville Standard Asbestos Built-

up Roofing. Our asphalts are carefully chosen and blended for longest life. We own no oil wells; we have no asphalt deposits to exploit; we buy only those materials that satisfactorily meet our high standards.

## Its Smooth Finished Surface

means quicker and better drainage; quick and easy tracing of leaks due to abuse or accident to the roofing and correction with the minimum of time, labor and expense.

Its smooth surface is particularly adapted to sawtooth construction. Where a slag or gravel surfaced roofing is used

for this construction the surfacing is likely to be separated from the felt by the sun and carried away by water, snow and ice, leaving the perishable rag felts exposed to the direct attack of sun and weather. As they are not intended for such exposure the surfacing must be quickly replaced or the felts may crack and disintegrate.

## It is Reinforced at the Vital Points

the valleys and flashings,—the places where practically 90% of all roofing troubles occur. The flashings are a com-

bination of asbestos special flashing fabric and Asbestile Cement, applied according to Johns-Manville specifications.

## It is Light in Weight

weighing approximately 300 to 400 pounds less per square than gravel or slag surfaced roofings.

Due to the durability of the materials used and the effectiveness of these specifi-

cations Johns-Manville can afford to back up the performance of its Asbestos Built-up Roofing, including the flashings, with Johns-Manville Responsibility.

## It is Approved by Underwriters' Laboratories, Inc.

and given Class "A" rating, whether applied over combustible or non-combustible surfaces. Where service conditions do not require a heavier Asbestos Built-up, as shown by the drawings on page 119,

our Asbestos Built-up Roofing—Underwriters' Class "B", as shown by the drawings on page 120, may be used.

In Johns - Manville Asbestos Built-up Roofing the user obtains the advantage of



the progressive improvements which our engineers develop from practical experience. They study each particular roof deck and plan its roofing to meet the re-

quirements of the structure and the service demanded. Some of the details of application as shown in this section will be of interest to architects and engineers.

### Johns-Manville Insulated Roofing

Where conditions of condensation or objectionable room temperatures from exterior conditions are encountered, Johns-Manville Insulated Asbestos Built-up Roofing will effectively eliminate a great percentage, if not all, of the trouble.

Johns-Manville Insulated Roofing is a combination of our Standard Asbestos Built-up Roofing applied over an efficient, durable, insulating felt that reduces the heat and cold conductivity of the roof deck.

This felt is known as Johns-Manville Roofinsul. The drawings on page 121 show some details of application of Johns-Manville Insulated Roofing. It is difficult to make any general recommendations as conditions govern to a large extent. We suggest that you take the matter up with the engineers at any of our branches and they will be glad to make a survey of plans or building and give full recommendations without any obligation on your part.

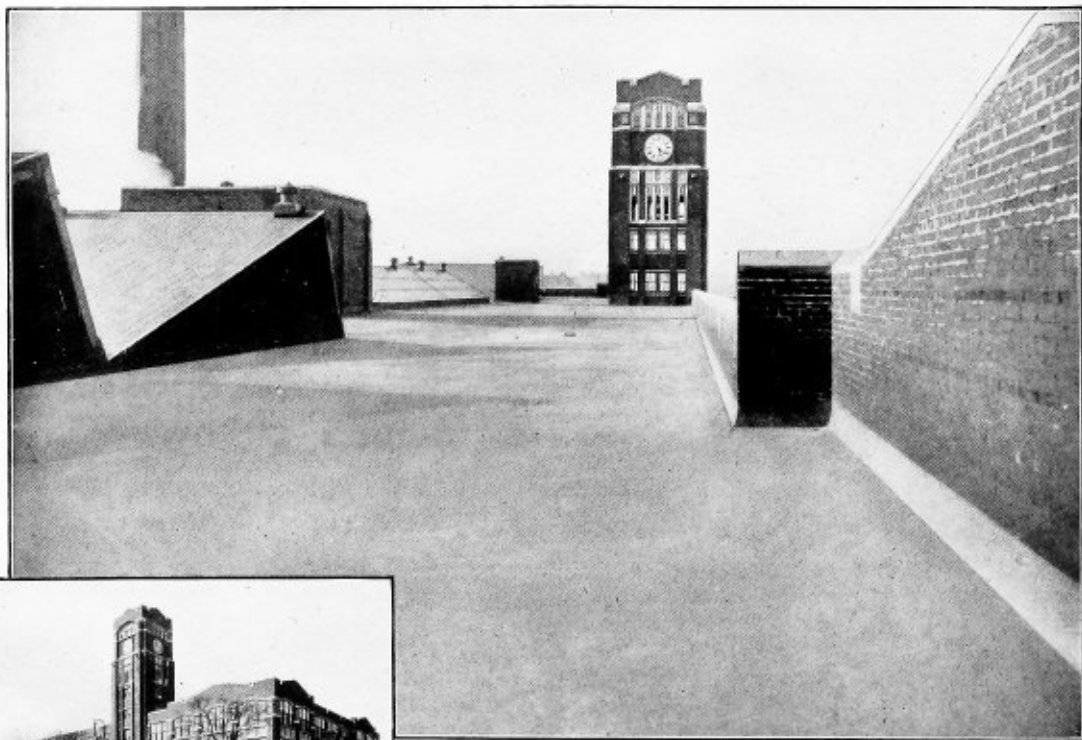

The clean, smooth, quick draining surface of Johns-Manville Standard Asbestos Built-up Roofing together with its other exclusive advantages are apparent on this building of C. P. Kimball & Co., Chicago, Ill.



## Specifications—Johns-Manville Standard Asbestos Built-up Roofing Over Wood Sheathing

Underwriters' Laboratories, Inc. Class "A"

On all wood roof decks as shown on plans apply Johns-Manville Standard Asbestos Built-up Roofing as follows:

### Materials

**Felts:** A heavy base sheet of asphalt impregnated asbestos roofing felt 32" wide, weighing approximately 60 lbs. per 108 square feet: to be Johns-Manville Standard Asbestos Built-up Roofing Felt.

Single ply sheets of asphalt impregnated asbestos roofing felt 32" wide, weighing approximately 14 lbs. per 108 square feet: to be Johns-Manville Asbestos Roofing Felt 14 lb.

**Nails:** To be 1" barbed nails and flat tin caps.  
**Asphalt Cement:** To be Johns-Manville Asphalt Roofing Cement.

Flashing material as specified hereinafter.

**Edging:** To be Johns-Manville Asbestos Flashing Material.

Such materials shall be applied over wood sheathing as follows:

### Application of Materials

1. Lay sheets of the 60 lb. felt directly over the sheathing. Lap the joints 3" and seal them with asphalt cement. Nail these sheets along the lap with barbed nails driven through flat tin caps, spaced 6" apart and in parallel lines approximately 10" apart and approximately 10" from the laps, these nails to be spaced 18" apart and staggered. The 60 lb. felt shall be laid parallel to pitch of roof and turned up 2" on all vertical surfaces, but not cemented to vertical surfaces.

Over the 60 lb. felt, Edging strips composed of the Flashing Material shall be applied at eaves and gable over-hang, extending 4" on roof, cemented and nailed and turned down over and secured to fascia and projected  $\frac{1}{2}$ " beyond to form a drip edge.

2. Mop the entire surface of the 60 lb. felt with the asphalt cement, heated to flow freely, and while the cement is hot, imbed in it sheets of the 14 lb. felt in two-ply construction, the 14 lb. felt to be run at right angles to the 60 lb. felt, lapped 17" and turned up 2" on all vertical surfaces.

Start at low point of roof with a one-half width sheet of the 14 lb. felt, then a full width sheet of the same felt laid flush with and entirely covering the one-half width sheet. Then lay full width sheets, setting the first so as to over-lap the one-half width starting sheet 2" and then exposing 15" of each succeeding sheet to the weather.

Mop the entire surface between plies with the asphalt cement, heated to flow freely, and roll the felts closely behind the mop so that no missing of asphalt can possibly take place. Approximately 30 lbs. of asphalt shall be used per square for each mopping.

Nail the back edge of each sheet with the barbed nails driven through flat tin caps spaced 9" apart; the center line of nail heads to be approximately  $\frac{3}{4}$ " below back edge of sheet.

3. When the roofing is otherwise complete, cover the entire surface with a mopping of the asphalt cement, to be applied hot, using approximately 25 lbs. to the square. (See detail on page 119.)

### Flashings

Walls and all other elevations above roof surface shall be carried vertically at least 12" to provide for proper flashing.

Roofing material shall be carried up on all vertical surfaces 2". All flashings, except those around venti-

lators, stand-pipes, exhausts, etc., shall be composed of base flashings of Johns-Manville Asbestos Flashing material, approximately 10 $\frac{1}{2}$ " wide, cemented and nailed to vertical surface. Such flashing shall be counter-flashed with Johns-Manville Asbestile System.

### Preparation of Roof Surface

*The following to be inserted in Carpenter's specifications:*

Sheathing boards shall be dry, well seasoned and of uniform thickness, laid closely—tongue and grooved sheathing preferred.

Roof surface shall be graded to drain all water freely into gutters and down-spouts. Ends of all sheathing boards shall rest on and be properly secured with at least two nails to joists or purlins. If edges of sheathing boards are curled up, they shall be drawn down and properly secured to joists or purlins, eliminating all standing nail heads and other projections. All loose

knots and other flaws shall be removed, and all holes properly filled or covered. All loose nails, chips and other rubbish shall be removed and the deck made and maintained perfectly clean and free of all obstructions other than tools and appliances of roofer. All drainage connections shall be set to permit free flow of water. A 3" x 3" triangular wood strip shall be furnished and installed (wherever base flashings are to be used) in the angle formed by roof and vertical surface. All to be done by owner or contractor other than roofing contractor.





## Specifications—Johns-Manville Standard Asbestos Built-up Roofing Over Non-Combustible Roof Surfaces

Underwriters' Laboratories, Inc. Class "A"

On all non-combustible roof decks as shown on plans apply Johns-Manville Standard Asbestos Built-up Roofing as follows:

### Materials

**Felts:** A heavy base sheet of asphalt impregnated asbestos roofing felt 32" wide, weighing approximately 60 lbs. per 108 square feet: to be Johns-Manville Standard Asbestos Built-up Roofing Felt.

Single ply sheets of asphalt impregnated asbestos roofing felt 32" wide, weighing approximately 14 lbs. per 108 square feet: to be Johns-Manville Asbestos Roofing Felt 14 lb.

**Asphalt Concrete Primer:** To be Johns-Manville Asphalt Concrete Primer.

**Asphalt Cement:** To be Johns-Manville Asphalt Roofing Cement.

Flashing materials as specified hereinafter.

**Edging:** To be Johns-Manville Asbestos Flashing Material.

Such materials shall be applied over DRY concrete or gypsum roof deck as follows:

### Application of Materials

1. Coat the concrete or gypsum with the cold primer, using approximately 1 gallon over concrete and 1 to 2 gallons over gypsum per 100 square feet of roof surface to provide a proper bond between roof deck and asphalt. Allow the primer to dry.

2. Mop the entire surface thus primed with the asphalt cement, heated to flow freely and while the cement is hot, imbed in it sheets of the 60 lb. felt. Lap the joints 3" and seal them with the hot asphalt cement. The 60 lb. felt shall be laid parallel to pitch of roof and turned up 2" on all vertical surfaces, but not cemented to vertical surfaces.

Over the 60 lb. felt, Edging strips composed of the Flashing Material shall be applied at eaves and gable over-hang extending 4" on roof, cemented and turned down over and secured to fascia and projected 1/2" beyond to form a drip edge.

3. Mop the entire surface of the 60 lb. felt with the hot asphalt cement, and while the cement is hot, imbed in it sheets of the 14 lb. felt, in two-ply construction, the 14 lb. felt to be run

at right angles to the 60 lb. felt, lapped 17" and turned up 2" on all vertical surfaces.

Start at low point of roof with a one-half width sheet of the 14 lb. felt; then a full width sheet of the same felt laid flush with and entirely covering the one-half width sheet. Then lay full width sheets, setting the first so as to overlap the one-half width starting sheet 2", and then exposing 15" of each succeeding sheet to the weather.

Mop the entire surface between plies with the asphalt cement, heated to flow freely, and roll the felts closely behind the mop so that no missing of asphalt can possibly take place. Approximately 30 lbs. of asphalt shall be used per square for each mopping.

4. On gypsum and other types of roof decks that permit of nailing, the laps of the 60 lb. felt and the back edges of the 14 lb. felts shall be securely nailed to roof slab with cut nails driven through flat tin caps in addition to mopping.

5. When the roofing is otherwise complete, cover the entire surface with a mopping of the asphalt cement, to be applied hot, using approximately 25 lbs. to the square. (See detail on page 119.)

### Flashings

Walls and other elevations above roof surface shall be carried vertically at least 12" to provide for proper flashings.

Roofing material shall be carried up on vertical surfaces 2". All flashings, except those around ventilators, stand-pipes, exhausts, etc., shall be composed of base flashings of Johns-Manville Asbestos Flashing material

approximately 10 1/2" wide. Such flashings shall be counter-flashed with Johns-Manville Asbestile System.

NOTE: On concrete surfaces maximum pitch upon which this roofing may be applied without nailing is 3" to the foot except on short runs, as in sawtooth construction. If wood nailing strips are inserted in concrete, the pitch may be increased.

### Preparation of Roof Surface

*The following to be inserted in Mason's specifications:*

Roof surface shall be graded properly to drain all water freely into gutters and down-spouts. Roof surface shall be finished smooth and hard, containing no depressions or projections and must be thoroughly set, air-dry and free from frost. All rubbish shall be removed and the deck made and maintained perfectly free

of all obstructions other than tools and appliances of the roofer. All drainage connections shall be set to permit free flow of water. The angle formed by roof and vertical surface (wherever base flashings are to be used) shall be rounded into proper cove. All to be done by owner or contractor other than roofing contractor.





## Specifications—Johns-Manville Asbestos Built-up Roofing Over Wood Sheathing

Underwriters' Laboratories, Inc. Class "B"

On all wood decks as shown on plans apply Johns-Manville Asbestos Built-up Roofing as follows:

### Materials

**Felts:** A heavy base sheet of asphalt impregnated asbestos roofing felt 32" wide, weighing approximately 60 lbs. per 108 square feet; to be Johns-Manville Standard Asbestos Built-up Roofing Felt.

Single ply sheets of asphalt impregnated asbestos roofing felt 32" wide, weighing approximately 14 lbs. per 108 square feet; to be Johns-Manville Asbestos Roofing Felt 14 lb.

**Nails:** To be 1" barbed nails and flat tin caps.  
**Asphalt Cement:** To be Johns-Manville Asphalt Roofing Cement.

Flashing material as specified hereinafter.

**Edging:** To be Johns-Manville Asbestos Flashing Material.

Such materials shall be applied over wood sheathing as follows:

### Application of Materials

1. Lay sheets of the 60 lb. felt directly over the sheathing. Lap the joints 3" and seal them with asphalt cement. Nail these sheets along the lap with barbed nails driven through flat tin caps, spaced 6" apart and in parallel lines approximately 10" apart and approximately 10" from the laps, these nails to be spaced 18" apart and staggered. The 60 lb. felt shall be laid parallel to pitch of roof and turned up 2" on all vertical surfaces, but not cemented to vertical surfaces.

Over the 60 lb. felt, Edging strips composed of the Flashing Material shall be applied at eaves and gable over-hang, extending 4" on roof, cemented and nailed, and turned down over and secured to fascia and projected  $\frac{1}{2}$ " beyond to form a drip edge.

2. Mop the entire surface of the 60 lb. felt with the asphalt cement, heated to flow freely, and while the cement is hot, imbed in it sheets of the 14 lb. felt in single-ply construction, the 14 lb. felt to be run at right angles to the 60 lb. felt, lapped 3" and turned up 2" on all vertical sur-

faces.

Start at low point of roof with a one-half width sheet of the 14 lb. felt, then a full width sheet of the same felt laid flush with and entirely covering the one-half width sheet. Then lay full width sheets, over-lapping the preceding ones 3", with 29" exposed to the weather.

Mop the entire surface between plies with the asphalt cement, heated to flow freely, and roll the felts closely behind the mop so that no missing of asphalt can possibly take place. Approximately 30 lbs. of asphalt shall be used per square for each mopping.

Nail the back edge of each sheet with the barbed nails driven through flat tin caps spaced 9" apart; the center line of nail heads to be approximately  $\frac{3}{4}$ " below back edge of sheet.

3. When the roofing is otherwise complete, cover the entire surface with a mopping of the asphalt cement, to be applied hot, using approximately 25 lbs. to the square. (See detail on page 120.)

### Flashings

Walls and all other elevations above roof surface shall be carried vertically at least 12" to provide for proper flashing.

Roofing material shall be carried up on all vertical surfaces 2". All flashings, except those around venti-

lators, stand-pipes, exhausts, etc., shall be composed of base flashings of Johns-Manville Asbestos Flashing material, approximately  $10\frac{1}{2}$ " wide, cemented and nailed to vertical surface. Such flashing shall be counter-flashed with Johns-Manville Asbestile System.

### Preparation of Roof Surface

*The following to be inserted in Carpenter's specifications:*

Sheathing boards shall be dry, well seasoned and of uniform thickness, laid closely—tongue and grooved sheathing preferred.

Roof surface shall be graded to drain all water freely into gutters and down-spouts. Ends of all sheathing boards shall rest on and be properly secured with at least two nails to joists or purlins. If edges of sheathing boards are curled up, they shall be drawn down and properly secured to joists or purlins, eliminating all standing nail heads and other projections. All loose

knots and other flaws shall be removed, and all holes properly filled or covered. All loose nails, chips and other rubbish shall be removed and the deck made and maintained perfectly clean and free of all obstructions other than tools and appliances of roofer. All drainage connections shall be set to permit free flow of water. A 3" x 3" triangular wood strip shall be furnished and installed (wherever base flashings are to be used) in the angle formed by roof and vertical surface. All to be done by owner or contractor other than roofing contractor.



## Specifications—Johns-Manville Asbestos Built-up Roofing Over Non-Combustible Roof Surfaces

Underwriters' Laboratories, Inc. Class "B"

On all non-combustible roof decks as shown on plans apply Johns-Manville Asbestos Built-up Roofing as follows:

### Materials

**Felts:** A heavy base sheet of asphalt impregnated asbestos roofing felt 32" wide, weighing approximately 60 lbs. per 108 square feet; to be Johns-Manville Standard Asbestos Built-up Roofing Felt.

Single ply sheets of asphalt impregnated asbestos roofing felt 32" wide, weighing approximately 14 lbs. per 108 square feet; to be Johns-Manville Asbestos Roofing Felt 14 lb.

**Asphalt Concrete Primer:** To be Johns-Manville Asphalt Concrete Primer.

**Asphalt Cement:** To be Johns-Manville Asphalt Roofing Cement.

Flashing materials as specified hereinafter.

**Edging:** To be Johns-Manville Asbestos Flashing Material.

Such materials shall be applied over DRY concrete or gypsum roof deck as follows:

### Application of Materials

1. Coat the concrete or gypsum with the cold primer, using approximately 1 gallon over concrete and 1 to 2 gallons over gypsum per 100 square feet of roof surface to provide a proper bond between roof deck and asphalt. Allow the primer to dry.

2. Mop the entire surface thus primed with the asphalt cement, heated to flow freely and while the cement is hot, imbed in it sheets of the 60 lb. felt. Lap the joints 3" and seal them with the hot asphalt cement. The 60 lb. felt shall be laid parallel to pitch of roof and turned up 2" on all vertical surfaces, but not cemented to vertical surfaces.

Over the 60 lb. felt, Edging strips composed of the Flashing Material shall be applied at eaves and gable over-hang, extending 4" on roof, cemented, and turned down over and secured to fascia and projected 1/2" beyond to form a drip edge.

3. Mop the entire surface of the 60 lb. felt with the hot asphalt cement, and while the cement is hot, imbed in it sheets of the 14 lb. felt, in single-ply construction, the 14 lb. felt to be

run at right angles to the 60 lb. felt, lapped 3" and turned up 2" on all vertical surfaces.

Start at low point of roof with a one-half width sheet of the 14 lb. felt; then a full width sheet of the same felt laid flush with and entirely covering the one-half width sheet. Then lay full width sheets, overlapping the preceding ones 3", with 29" exposed to the weather.

Mop the entire surface between plies with the asphalt cement, heated to flow freely, and roll the felts closely behind the mop so that no missing of asphalt can possibly take place. Approximately 30 lbs. of asphalt shall be used per square for each mopping.

4. On gypsum and other types of roof decks that permit of nailing, the laps of the 60 lb. felt and the back edges of the 14 lb. felts shall be securely nailed to roof slab with cut nails driven through flat tin caps in addition to mopping.

5. When the roofing is otherwise complete, cover the entire surface with a mopping of the asphalt cement, to be applied hot, using approximately 25 lbs. to the square. (See detail on page 120.)

### Flashings

Walls and other elevations above roof surface shall be carried vertically at least 12" to provide for proper flashings.

Roofing material shall be carried up on vertical surfaces 2". All flashings, except those around ventilators, stand-pipes, exhausts, etc., shall be composed of base flashings of Johns-Manville Asbestos Flashing material

approximately 10 1/2" wide. Such flashings shall be counter-flashed with Johns-Manville Asbestile System.

**NOTE:** On concrete surfaces maximum pitch upon which this roofing may be applied without nailing is 3" to the foot except on short runs, as in sawtooth construction. If wood nailing strips are inserted in concrete, the pitch may be increased.

### Preparation of Roof Surface

The following to be inserted in Mason's specifications:

Roof surface shall be graded properly to drain all water freely into gutters and down-spouts. Roof surface shall be finished smooth and hard, containing no depressions or projections and must be thoroughly set, air-dry and free from frost. All rubbish shall be removed and the deck made and maintained perfectly

free of all obstructions other than tools and appliances of the roofer. All drainage connections shall be set to permit free flow of water. The angle formed by roof and vertical surface (wherever base flashings are to be used) shall be rounded into proper cove. All to be done by owner or contractor other than roofing contractor.



# Johns-Manville Service to Industry

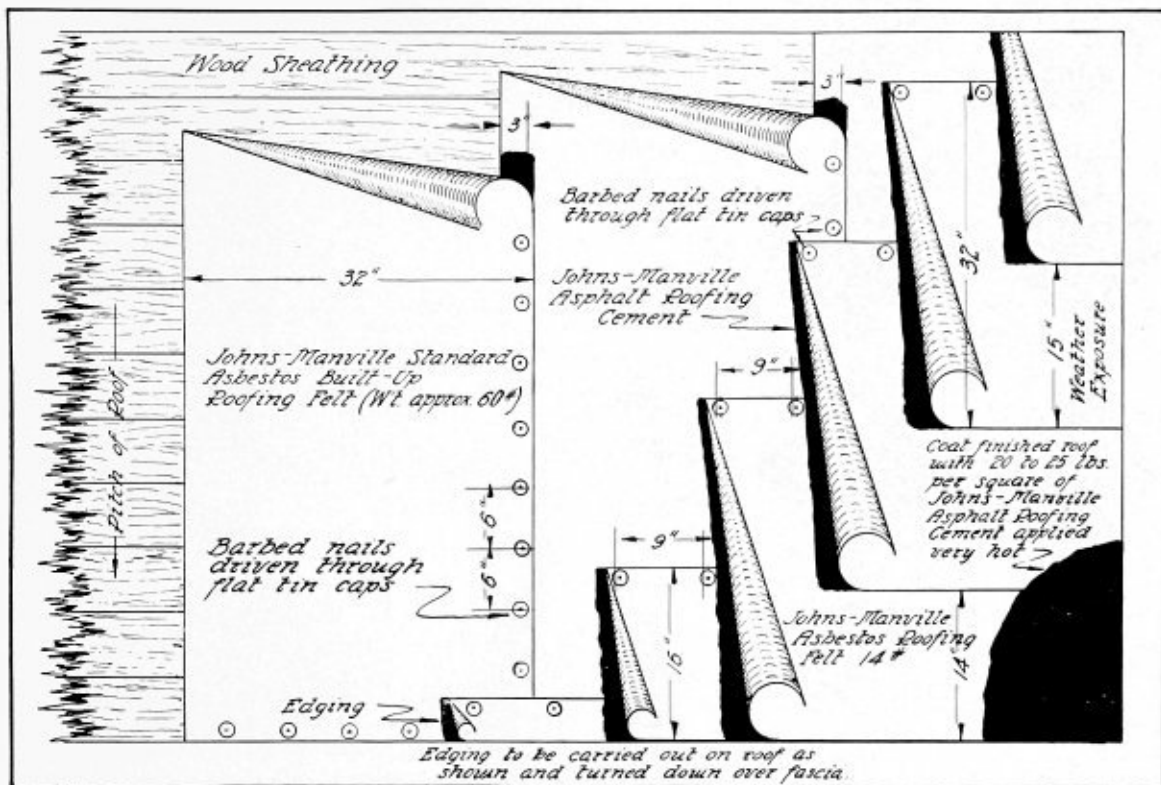

Details of application of Johns-Manville Standard Asbestos Built-up Roofing—Underwriters' Laboratories Class "A" over wood sheathing: Drawing R-94-S

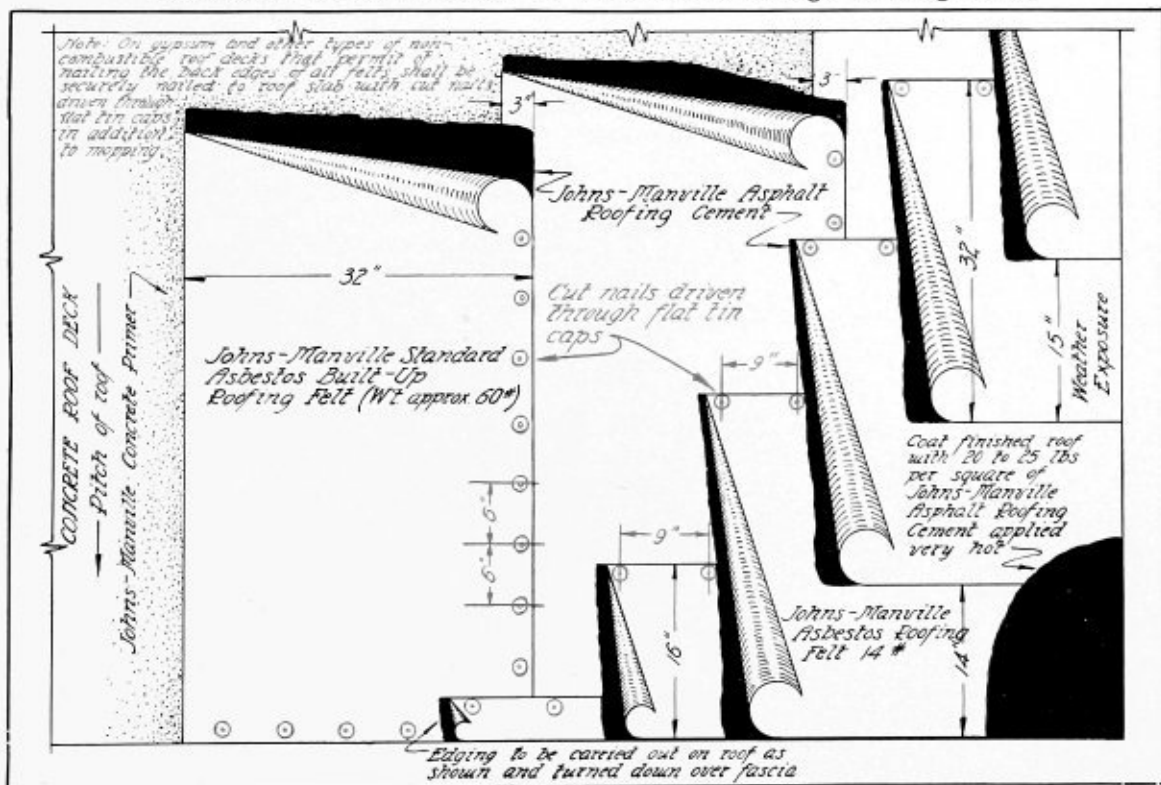

Details of application of Johns-Manville Standard Asbestos Built-up Roofing—Underwriters' Laboratories Class "A" over non-combustible roof surfaces: Drawing R-94-C





# Johns-Manville Service to Industry

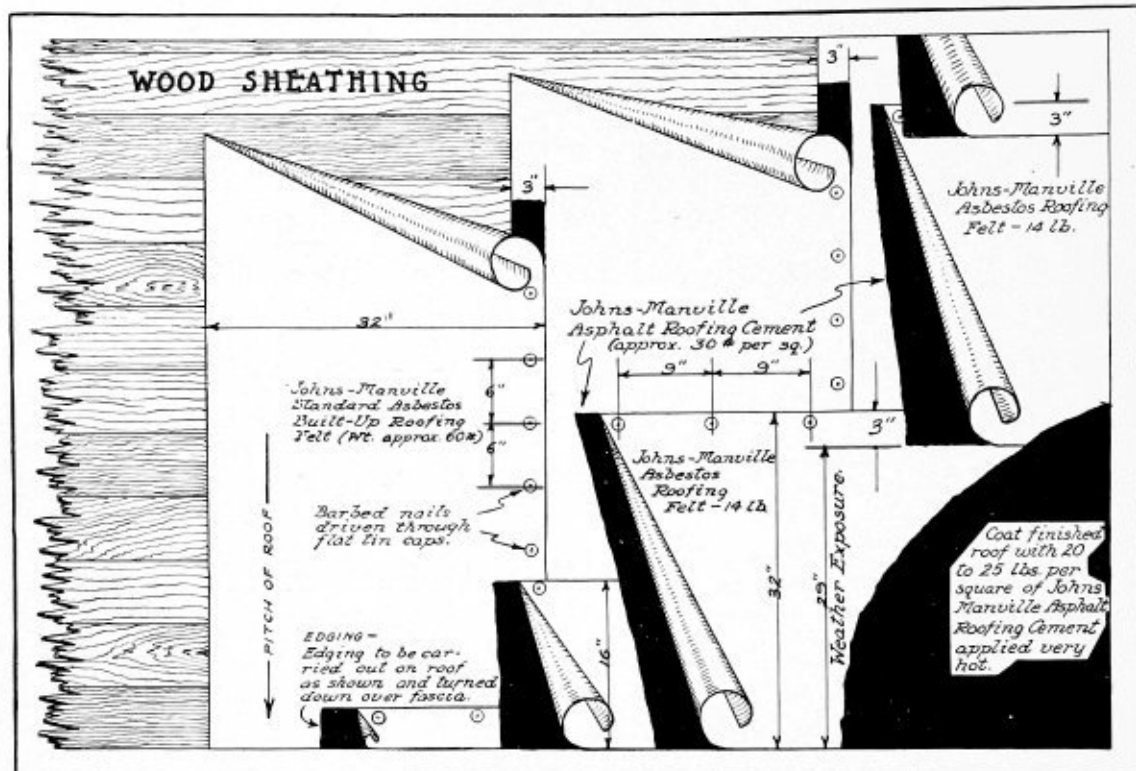

Details of application of Johns-Manville Asbestos Built-up Roofing—Underwriters' Laboratories Class "B" over wood sheathing: Drawing R-38

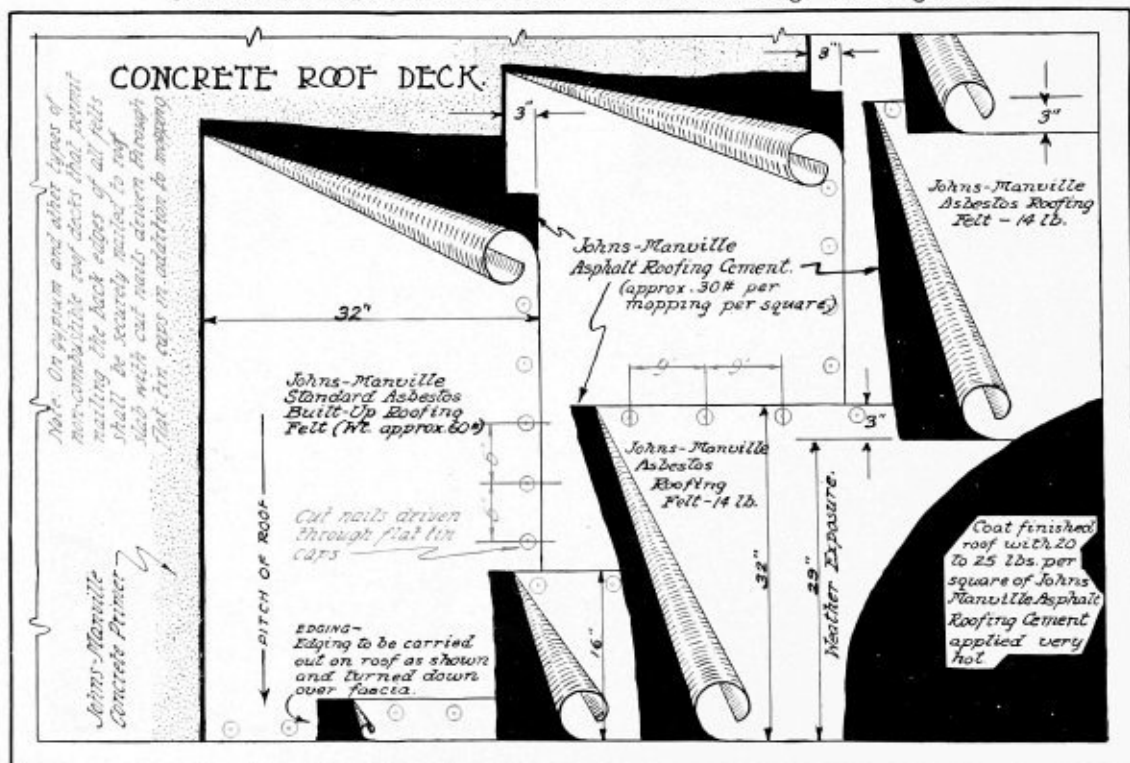

Details of application of Johns-Manville Asbestos Built-up Roofing—Underwriters' Laboratories Class "B" over non-combustible roof surfaces: Drawing R-39





# Johns-Manville Service to Industry

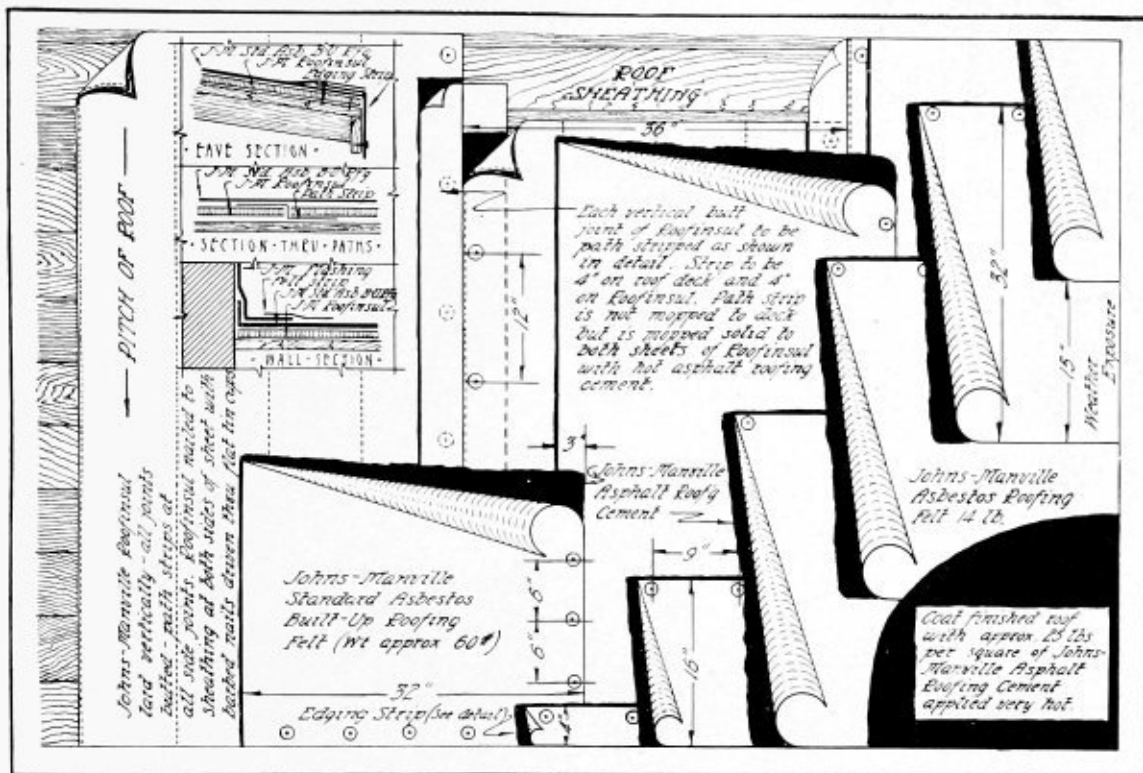

Details of application of Johns-Manville Roofinsul ( $\frac{1}{4}$ " or  $\frac{1}{2}$ " thick) in connection with Johns-Manville Standard Asbestos Built-up Roofing—Path Method—Sheathing—Drawing R-42

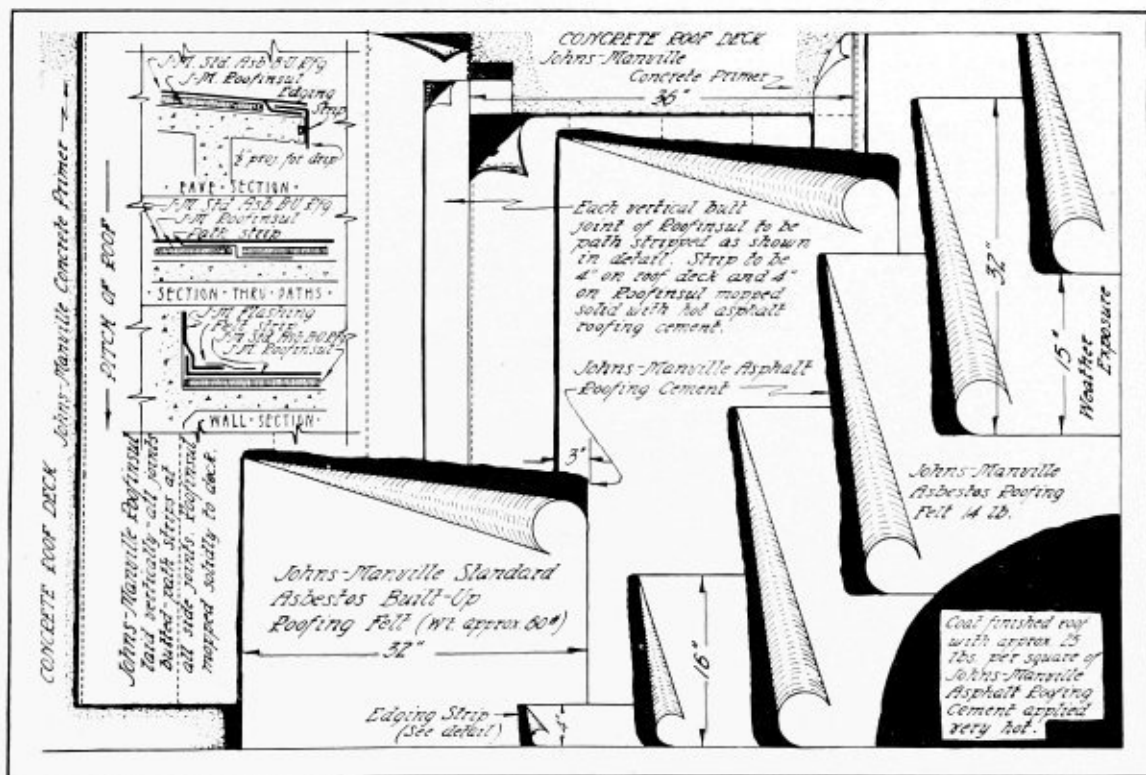

Details of application of Johns-Manville Roofinsul ( $\frac{1}{4}$ " or  $\frac{1}{2}$ " thick) in connection with Johns-Manville Standard Asbestos Built-up Roofing—Path Method—Concrete—Drawing R-43

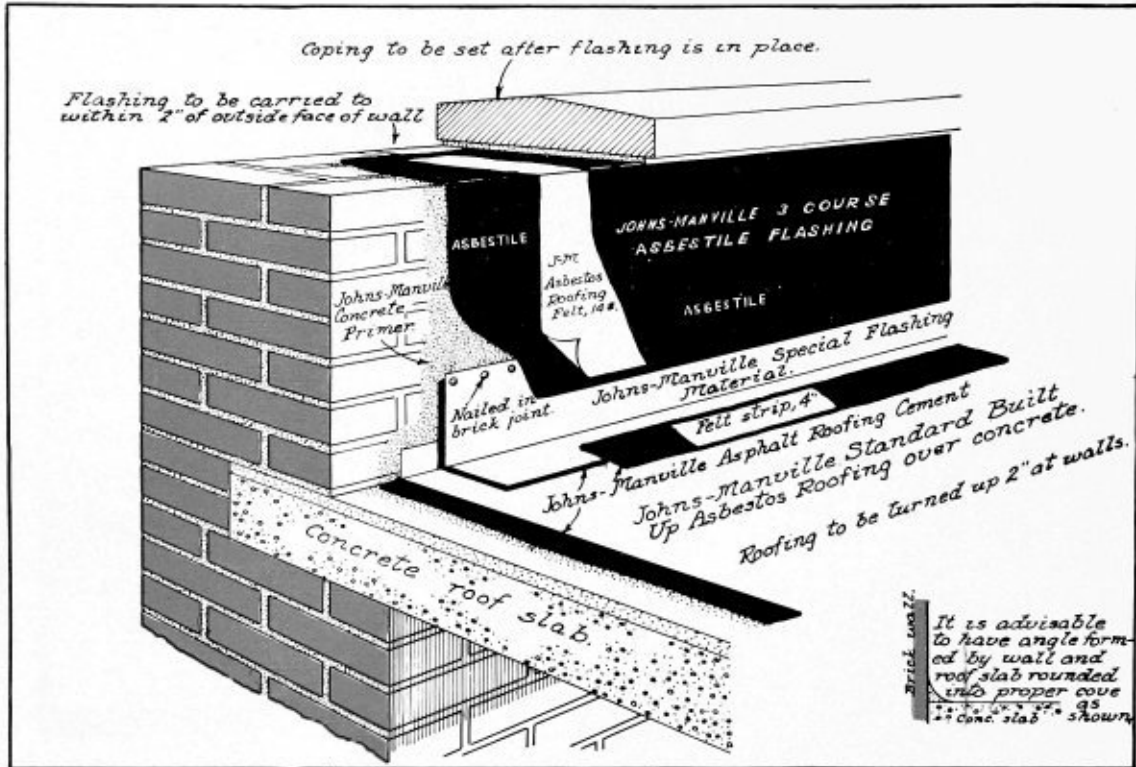

Details of Johns-Manville Asbestile System of Flashing—Cap flashing carried up wall and across top under coping to within 2" of outside face—Drawing F-18.

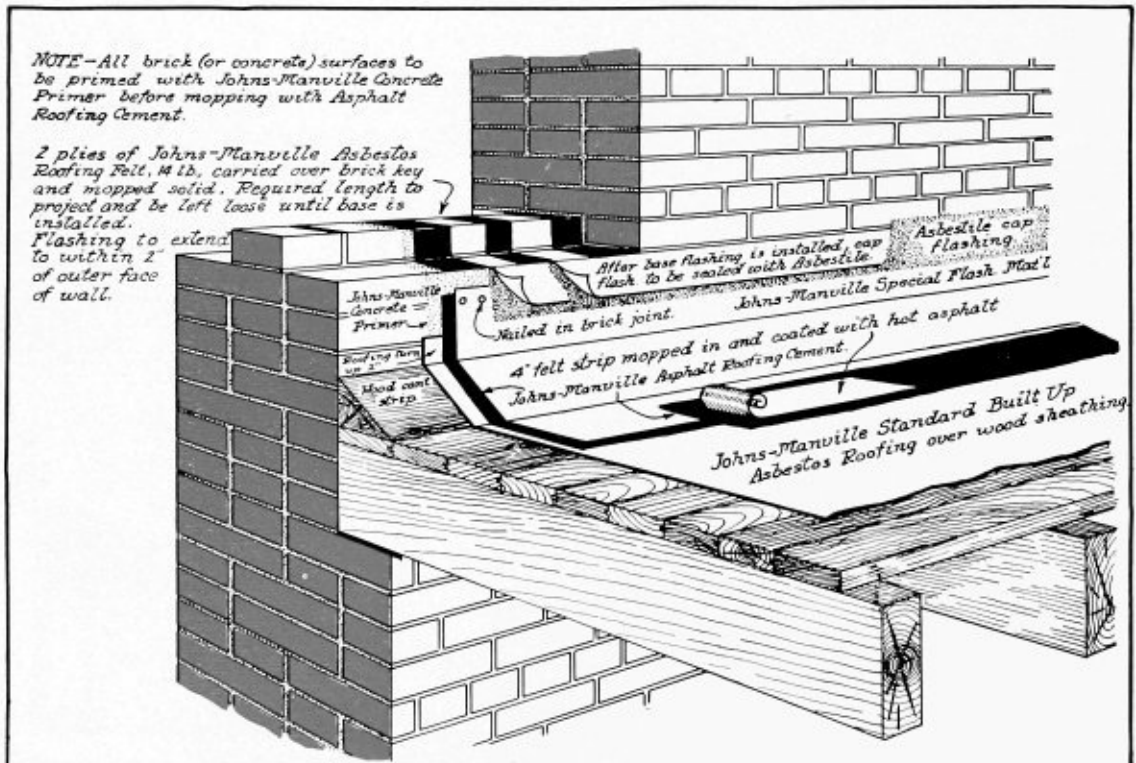

Details of Johns-Manville Flashing—Cap flashing carried through wall over brick key to within 2" of outside face—Drawing F-24.



# Johns-Manville Service to Industry

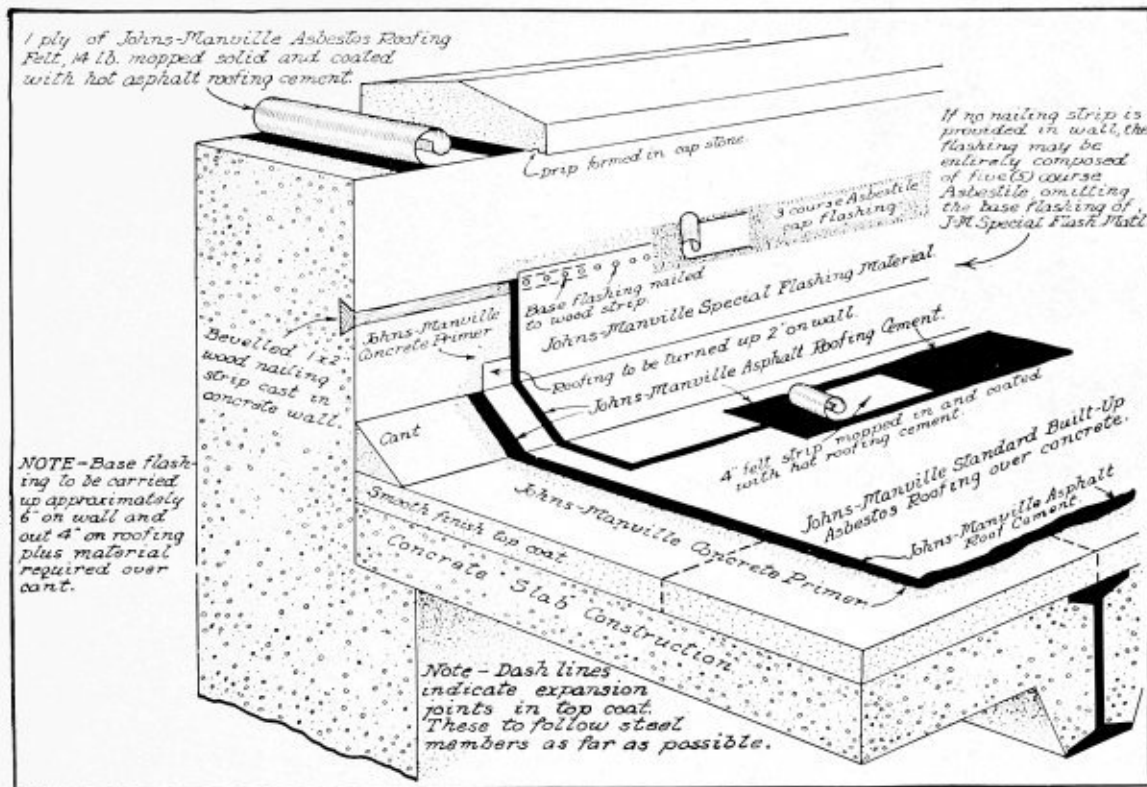

Details of Johns-Manville Asbestile System of Flashing.  
(Concrete wall and concrete roof deck)—Drawing F-27.

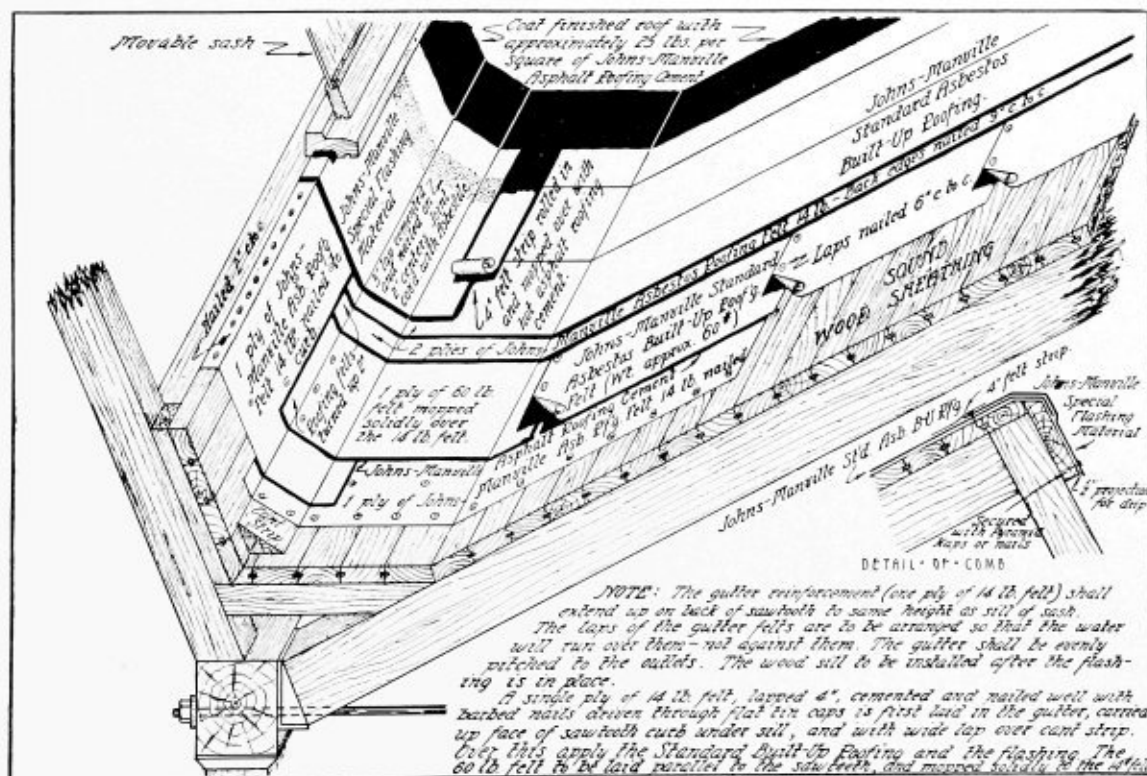

Details of Johns-Manville Built-up Gutter in wood sawtooth construction—Drawing G-20



# Johns-Manville Service to Industry

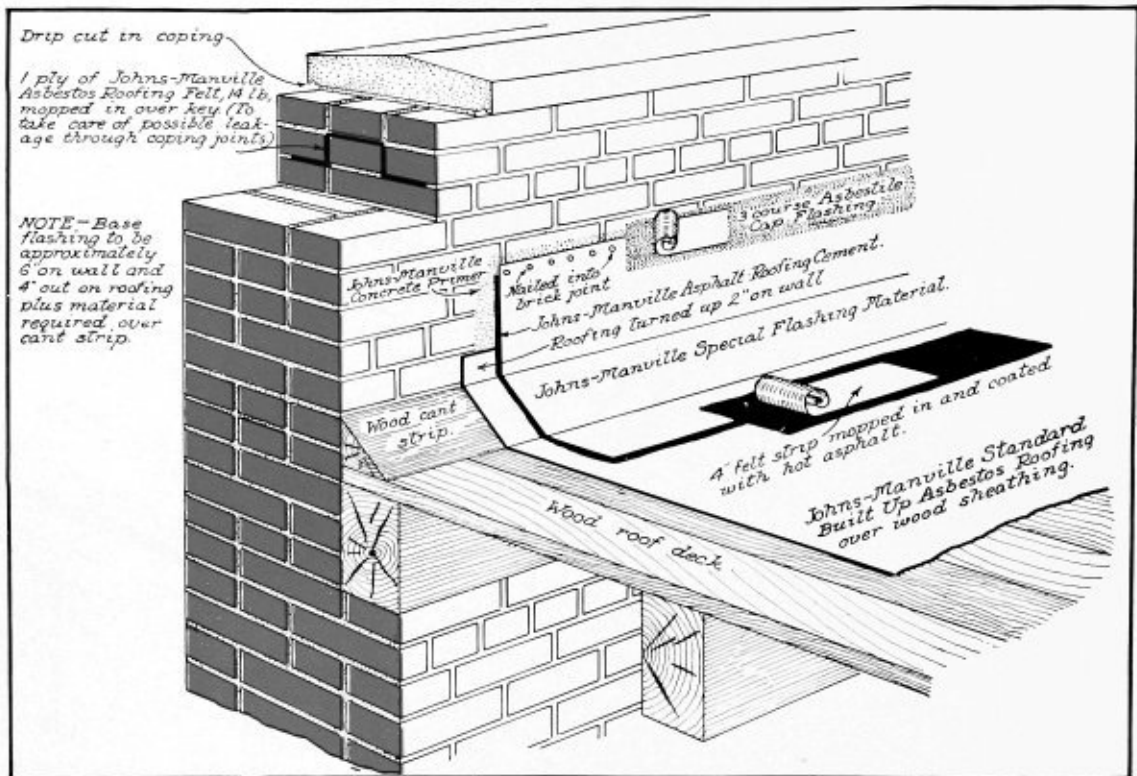

Details of Johns-Manville Asbestile System of Flashing.  
(Brick wall and wood deck)—Drawing F-28.

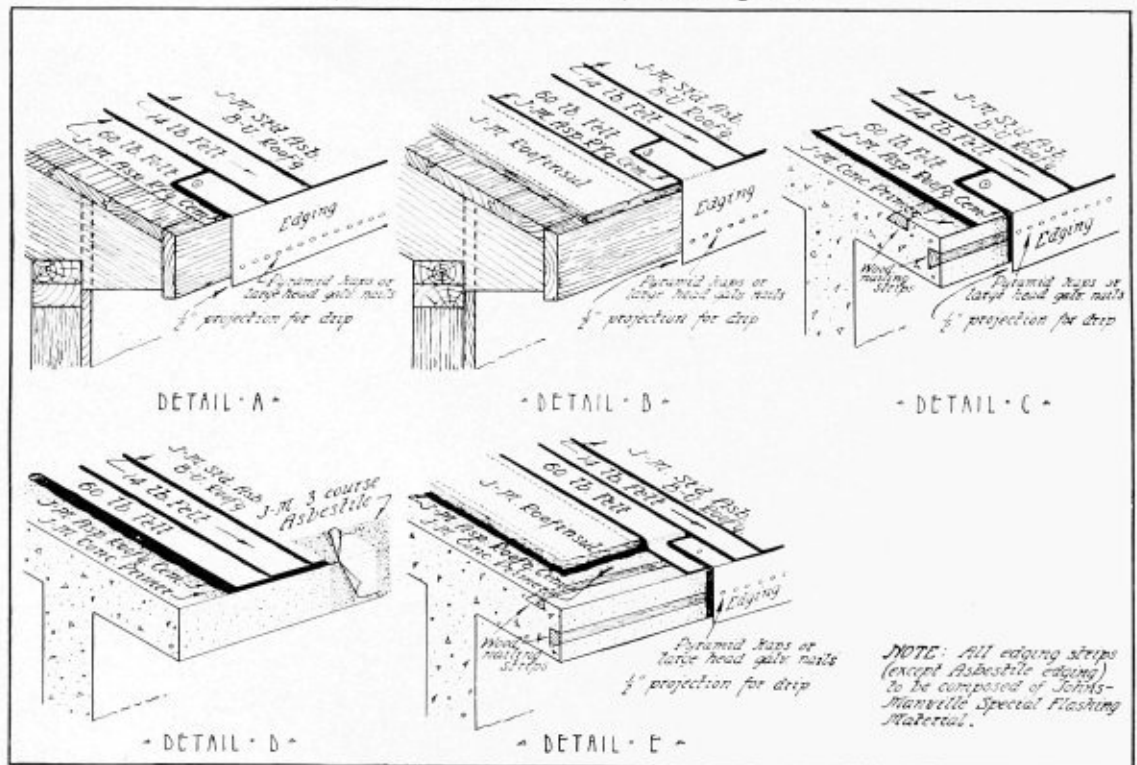

Details of Edging Strips in connection with Johns-Manville Standard Asbestos Built-up Roofing—Drawing F-31





The natural durability of Johns-Manville Asbestos Roofing assures continuing satisfactory and economical service against the destructive acid fumes, severe climate and other conditions at the mines of the Inspiration Copper Co., Miami, Ariz.

## Johns-Manville Asbestos Ready-to-Lay Roofings

**J**OHNS-MANVILLE Asbestos Ready-to-lay Roofings give years of positive protection against fire and weather. On a comparative basis—as to first cost plus repair cost — Johns - Manville Asbestos Ready-to-lay Roofings effect a saving which represents a splendid return on the investment. That's why they are called the "cheapest-per-year" roofings.

Their low upkeep is due to the unchanging properties of the raw material, asbestos, plus proper design and manufacture.

These properties are not subject to variation, nor are they dependent upon any coating or reinforcement which requires periodical renewal. It is because of what's **IN** them—not **ON** them—that Johns-Manville Asbestos Ready-to-lay Roofings give years of fire and weather protection to the buildings they cover.

Selected asbestos fibres are fabricated

by special machinery into strong compact felts, which in turn are thoroughly impregnated with natural asphalts of known value for durability.

And this asphalt impregnation does not dry out. It is held intact and protected in the body of the felt—actually sealed there because, unlike animal or vegetable fibres, asbestos fibres are non-tubular. They are immune to the capillary attraction set up by sun and weather, which draws off the asphaltic oils of roofings composed of tubular animal or vegetable fibres.

Made in different styles and weights to meet different types of buildings and varying service conditions. Suitable for application on factory and farm buildings, engine houses, sheds, stations, tool houses, warehouses, shops, elevators or on any type of building where a ready-to-lay roofing is desired.



## Flexstone Brand Asbestos Ready Roofings

### Smooth Surfaced

#### Double Coated

**M**ADE of heavy, tough felt of asbestos fibres thoroughly impregnated with natural asphalt and then heavily coated on both sides with asphalt.

Packed in one-square rolls which include completing materials and instructions for application. Shipping weight approximately 55 lbs. per square.

#### Heavy

A rugged asbestos roofing of special strength.

Made of three plies of asbestos felt. Packed in one-square rolls which include completing materials and instructions for application. Shipping weight, approximately 60 lbs. per square.

Also made in sheets 32" x 80" which are shipped six sheets to a square and five squares to the crate. Shipping weight approximately 72 lbs. per square, crated, including completing materials.

#### Extra Heavy

The heaviest type of Flexstone. Made of four plies of asbestos felt. Particularly adapted for service where acid or gas conditions exist.

Furnished only in sheets 32" x 80". Packed in crates, 6 sheets to the square; 4 squares to the crate. Shipping weight approximately 95 lbs. per square, crated, including completing materials.

### Slate Surfaced

Flexstone slate surfaced roofing combines the attractiveness of a colored surface with the fire protection of asbestos. Where a roofing must be ornamental as well as durable this type will meet every requirement.

It is made of the same asbestos fibres as Flexstone Smooth Surfaced Roofing. The crushed slate is imbedded in the asphalt coating while it is hot. The asphalt used is carefully chosen and blended and retains its durability under all weather conditions and affords a positive, firm, constant grip on the particles of the surfacing.

Furnished with a surfacing of crushed red, green or blue-black slate. The choice of surface color is merely a matter of personal taste or of harmonizing the roof with the side-wall coloring.

Packed in one-square rolls which include completing materials and instructions for application. Shipping weight, approximately 80 lbs. per square.

#### Underwriters' Approval

Johns-Manville Asbestos Ready-to-lay Roofings, Flexstone and White Top Brands, are approved by Underwriters' Laboratories, Inc., and take base rates of insurance.

And they are backed not only by a definite guarantee, but by the broader and more satisfactory terms of the Johns-Manville plan of Roof Registration, described on page 110.

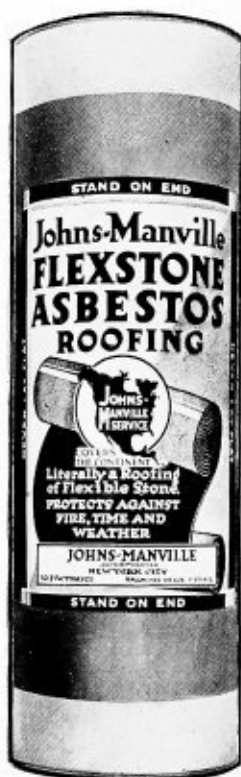

Industry has found in Johns-Manville Flexstone and other Asbestos Roofings the cheapest per year roofings.



## White Top Asbestos Ready Roofing

**J**OHNS-MANVILLE White Top Asbestos Roofing is particularly adapted for saw-tooth construction and buildings where the white surface of the roofing has the advantage of reflecting a maximum of sunlight into the interior of the building; also widely used on buildings where a clean, neat, white roof surface is desired.

Made of two or three plies of asphalt impregnated asbestos felt and one ply of unimpregnated (white), asbestos felt, cemented together with asphalt. It can be laid either side to the weather but where

white side is exposed the pitch of the roof must be at least 3" to the foot.

Made in two weights—heavy and extra heavy. Heavy is shipped in rolls of 1 or 2 squares which include necessary completing materials and full instructions for application. Approximate shipping weight 62 lbs. per square. Extra Heavy is furnished only in sheets 32" wide by 80" long, 6 sheets to the square; 4 squares to the crate. Approximate shipping weight 90 lbs. per square, crated, including completing materials.

## Safeguard the Application with Pyramid Kaps



(Fig. 1)



(Fig. 2)

Under the old system (Fig. 1) nails driven into cracks work loose and eventually come out, leaving holes through both layers of roofing, causing leaks. Under the Pyramid Kap System (Fig. 2) the continuous pressure of the strip and the adjoining kaps eliminate all trouble from this source.

We recommend the application of all our Ready-to-lay Roofings with Pyramid Kaps. These are patented fasteners that exert a positive, even and continuous pressure along all laps and provide a more satisfactory weathertight and watertight job than is possible with nails and cement.

Pyramid Kaps are designed for quick and easy application and applied, end to end, along the entire length of all horizontal and vertical laps, provide a continuous, evenly distributed pressure at all points where the roofing felts are joined.

Experience clearly shows that nails driven through tin caps or large headed nails and cement are woefully inefficient. Their principal fault is that they offer but a relatively small and intermittent binding pressure over the laps (when spaced the usual 2" apart) and permit the roofing fabric to pucker and buckle between the

nailing points and to tear away at the laps under the strains from expansion, contraction and wind pressure.

90% of all leaks experienced with ready-to-lay roofing can be traced to faulty laps which are so difficult to avoid when only nails and cement are used in the application. These troubles are positively avoided by the use of Pyramid Kaps, which in addition to their great efficiency enhance the general appearance of the finished job, giving a neat, standing-seam effect.

Pyramid Kaps are furnished only when ordered, and at slight additional cost, but this is negligible when their advantages and the satisfaction they afford the user are considered.

Be sure to specify Pyramid Kaps in your orders for Asbestos Ready-to-lay Roofing.





## Standard Specifications for the Application of Johns-Manville Asbestos Ready-to-Lay Roofings

**F**OR Asbestos Ready-to-lay Roofings applied over wood sheathing, monitor type roofs, slow burning mill construction with saw-tooth roof, steep surfaces, etc.

Note: The following specifications apply to Johns-Manville Flexstone Asbestos Roofing (Double Coated, Heavy and Ex-

tra Heavy); Johns-Manville White Top (Heavy and Extra Heavy) and Flexstone Asbestos Slate Surfaced Roofing.

On White Top Asbestos Roofing and Flexstone Asbestos Slate Surfaced Roofing there is a black selvaged edge on one side to permit proper joining at horizontal laps.

### Materials

Asbestos roofing, 32" wide, ready for application, to be Johns-Manville Asbestos Ready-to-lay Roofing.....Brand.

Cement for laps of roofing to be Johns-Manville Lap Cement.

Roofing Fasteners to be Zinc Pyramid Kaps and special galvanized round head Pyramid Kap

nails; or 7/8" large head, galvanized roofing nails.

Flashing materials as specified hereinafter.

Gutters and valleys to be lined with Johns-Manville Standard Asbestos Built-Up Gutter and Valley Lining.

Such materials shall be applied over wood sheathing as follows:

### Application of Materials

1. When in rolls cut the roofing materials into sheets approximately 13' 6" in length. When in sheets apply as received. Commence at eaves or gutters and apply such sheets parallel with them, flush with edge and over edging strip of special flashing material, which shall have been previously applied.

2. Lap horizontal joints 2" and apply an intermediate layer of Johns-Manville Lap Cement.

3. Lay sheets so that vertical joints will break joints with preceding courses of sheets as in brickwork. Butt the ends of the sheets at vertical joints closely together without lapping. Lay, with black side up (in all cases), the 6" wide strips of asbestos felt (furnished with all Johns-Manville Asbestos Ready-to-lay Roofing except Flexstone Double Coated) underneath each vertical joint, extending it 3" on each side of joint for entire width of roofing sheet. Be sure that lower end of butt lap is led out on top of sheet below. Cover each strip of felt furnished for a butt end joint with lap cement, and imbed the butted ends of roofing sheets into this cement.

With the Flexstone Double Coated Roofing lap the end joints 4", applying a coating of lap cement in the joint.

4. Secure all horizontal lapped joints with Pyramid Kaps butted end to end approximately 1/2" from edge of sheet or with large head galvanized roofing nails on about 2" centers 1/2" from edge of sheet. Secure all vertical butted joints in a similar manner applying one row of fasteners on each side of vertical joint about 3/4" back from same.

With the Flexstone Double Coated Roofing secure all vertical lapped joints with the large head nails spaced 1" apart, staggered, or with the Pyramid Kaps butted end to end.

5. Extend top sheets on each side of ridge approximately 2" over ridge; lapping one sheet over the other and nailing on 9" centers.

6. Apply a cap or finishing strip cut from roofing material, approximately 10 1/2" wide, lengthwise of ridge; extend it equally on each side of ridge and thoroughly secure its lower edges with large head galvanized nails or Pyramid Kaps.

### Flashings

Walls and all other elevations above roof surface shall be carried vertically at least 12" to provide for proper flashings. If such flashings are to

be constructed in accordance with Johns-Manville Asbestile System, such walls and other elevations need not extend more than 8" to 10"





above roof surface, unless otherwise demanded by local building authorities.

Roofing material shall be carried up on vertical surface approximately 2". All flashings, except those around ventilators, standpipes, exhausts,

etc., shall be composed of base flashings, of special Asbestos Flashing Material, approximately 10½" wide, cemented and nailed to vertical surface. Such flashings shall be counter-flashed with Johns-Manville Asbestile System.

## Preparation of Roof Surface

*(To be inserted in Carpenter's Specification)*

Roof surface shall be graded to drain all water freely into gutters and downspouts.

Sheathing boards shall be dry, well seasoned and of uniform thickness, laid closely—tongue-and-grooved sheathing preferred. Ends of all sheathing boards shall rest on and be properly secured with at least two nails to joists or purlins. If edges of sheathing boards are curled up, they shall be drawn down and properly secured to joists or purlins, eliminating all standing nail heads and other projections. All loose knots and

other flaws shall be removed, and all holes properly filled or covered. All loose nails, chips and other rubbish shall be removed and the deck made and maintained perfectly clean and free of all obstructions other than tools and appliances of roofer. All drainage connections shall be set to permit free flow of water. A 3" x 3" triangular wood strip shall be furnished and installed (wherever base flashing is to be used) in the angle formed by the roof and vertical surface. All to be done by owner or contractor other than roofer.

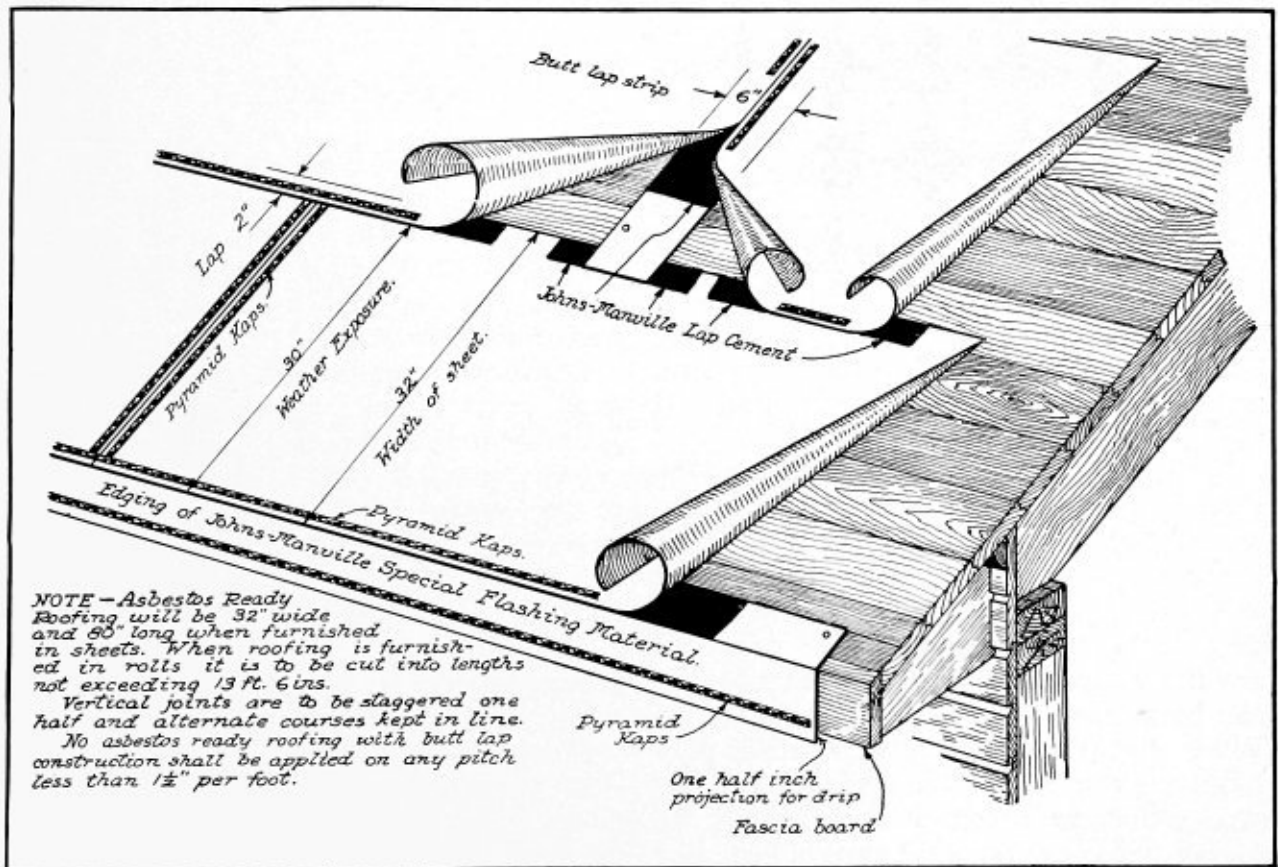

Details of Application of Johns-Manville Asbestos Ready-to-lay Roofing.  
Drawing R-25.

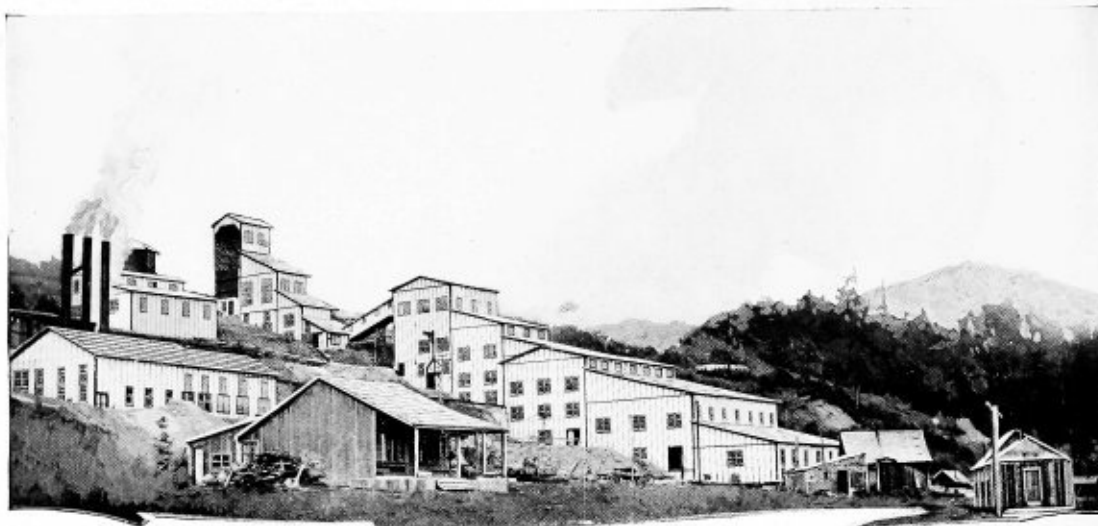

Washington Power and Reduction Co., Republic, Wash., showing application of Asbestoside with batten strips placed over vertical joints.

## Johns-Manville Asbestoside

**J**OHNS-MANVILLE Asbestoside is an asbestos sheet wall siding (without metal reinforcement) for application directly over sheathing on factory and farm buildings, warehouses, lumber sheds, grain elevators, repair shops and other buildings where protection against fire, water, gases, chemical fumes and all weather conditions is desired.

This material is composed of two or three plies of asphalt impregnated asbestos felt and one ply of white or unimpregnated asbestos felt, all cemented together at the factory with asphalt. The unimpregnated sheet of asbestos felt produces a white surface on one side. The material can be applied either side to the weather. When the white side is exposed it provides a clean, attractive surface that improves the appearance of the building. As Asbestoside is a non-conductor of heat and cold, it keeps buildings cooler in summer and warmer in winter.

Can be applied perpendicularly or horizontally. When applied perpendicularly the three ply roll stock should be used and wooden batten strips should be applied over all joints, thus giving an attractive half-timber effect.

Completing materials consist of large head, thin shank, galvanized nails, or Johns-Manville Pyramid Kaps, as ordered.

Star Brand (3-ply) is furnished in rolls of one square of 108 square feet or two squares of 216 square feet, weighing approximately 64 lbs. per square; also in sheets 16 x 50" weighing approximately 70 lbs. per square, crated, without completing materials. Shipped in crates containing 1 to 5 squares.

Shield Brand (4-ply) is furnished in 16 x 50" sheets only, weighing approximately 90 lbs. per square, crated, without completing materials. Shipped in crates containing 1 to 5 squares.



## Standard Specifications for the Application of Johns-Manville Asbestoside (Exterior Wall Siding)

### Applied Horizontally

Material to be applied over siding of building as specified shall be:

Asbestos Sheet siding ready for application in sheets 16" x 50"; to be Johns-Manville Asbestoside, Star or Shield Brand.

Fasteners to be either Johns-Manville large headed galvanized roofing nails or Pyramid Kaps and special nails, as specified.

Such material shall be applied over wood sheathing as follows:

If corner boards are to be used first apply a strip of Asbestoside of sufficient width to cover corner of building and extend 3" from under corner boards after they have been applied. The joints of these strips to be butted.

Top of door or window openings shall have a strip of Asbestoside approximately 10" wide applied so that it will rest on and extend over the face of the casing.

Sides and bottom of door and window openings shall be faced with a strip of Asbestoside of sufficient width to extend 3" beyond edge of casing. The joints of such strips shall be butted.

Corner boards and door and window casings may now be installed. If corner boards are not to be used apply Siding so that sheets will extend flush with corners of the building. If corner boards are used apply Siding so that sheets will butt against corner boards, covering the 3" extension of the strip previously installed underneath corner boards.

At door and window openings apply Siding so

that sheets will butt against casing, covering the 3" extension of strip previously applied under casing. Siding sheets shall be applied lengthwise, white side to the weather and parallel with the cornice and eaves. Perpendicular joints shall be lapped 3". Horizontal joints shall be lapped 2".

Start first course at top with a full sheet, tucking the upper edge of same underneath the finish or frieze board.

Start the second course with a half sheet so that succeeding joints will break in the center of the sheet above.

Start the third course with a full sheet, the fourth course with a half sheet and so on in rotation to break joints.

To insure the proper alignment and the even application of Asbestoside, chalk lines should be snapped across the building.

All seams shall be properly secured with large head roofing nails or oval head nails and Pyramid Kaps. If large head nails are used they shall be spaced on 2" centers  $\frac{3}{4}$ " back from the edge of sheet. If oval head nails and Pyramid Kaps are used Kaps shall be butted end to end and placed  $\frac{3}{4}$ " back from edge of sheet.

If corner boards are not used apply over corner of building and Asbestoside previously applied, 8" wide strips of Asbestoside bent at right angles so that they will lap 4" on the Asbestoside on each side. These strips to be fastened along both edges with large head nails or oval head nails and Pyramid Kaps.

### Applied Perpendicularly

Where it is desired to apply Asbestoside perpendicularly material in roll form 32" wide to be used. Sheets are to be cut from the roll not more than 10 ft. long.

The details of application, strips, lapping, fastening, etc., are the same as when the material

is applied horizontally. If desired, unplanned wooden battens, 3" to 6" wide, may be applied over the laps of the finished job, thus giving the building a half timber effect. These strips may be stained or painted as desired.

### Preparation of Surface

*(To be inserted in Carpenter's Specification)*

Sheathing boards shall be dry, well seasoned and of uniform thickness laid closely, tongue and grooved sheathing preferred. Ends of all sheathing boards shall rest on and be properly secured with at least two nails to joists or studs. If edges of sheathing boards are curled up they shall be

drawn down and properly secured to joists or studs eliminating all standing nail heads and other projections. All loose knots and other flaws shall be removed and all holes properly filled or covered. All to be done by owner or other contractors.

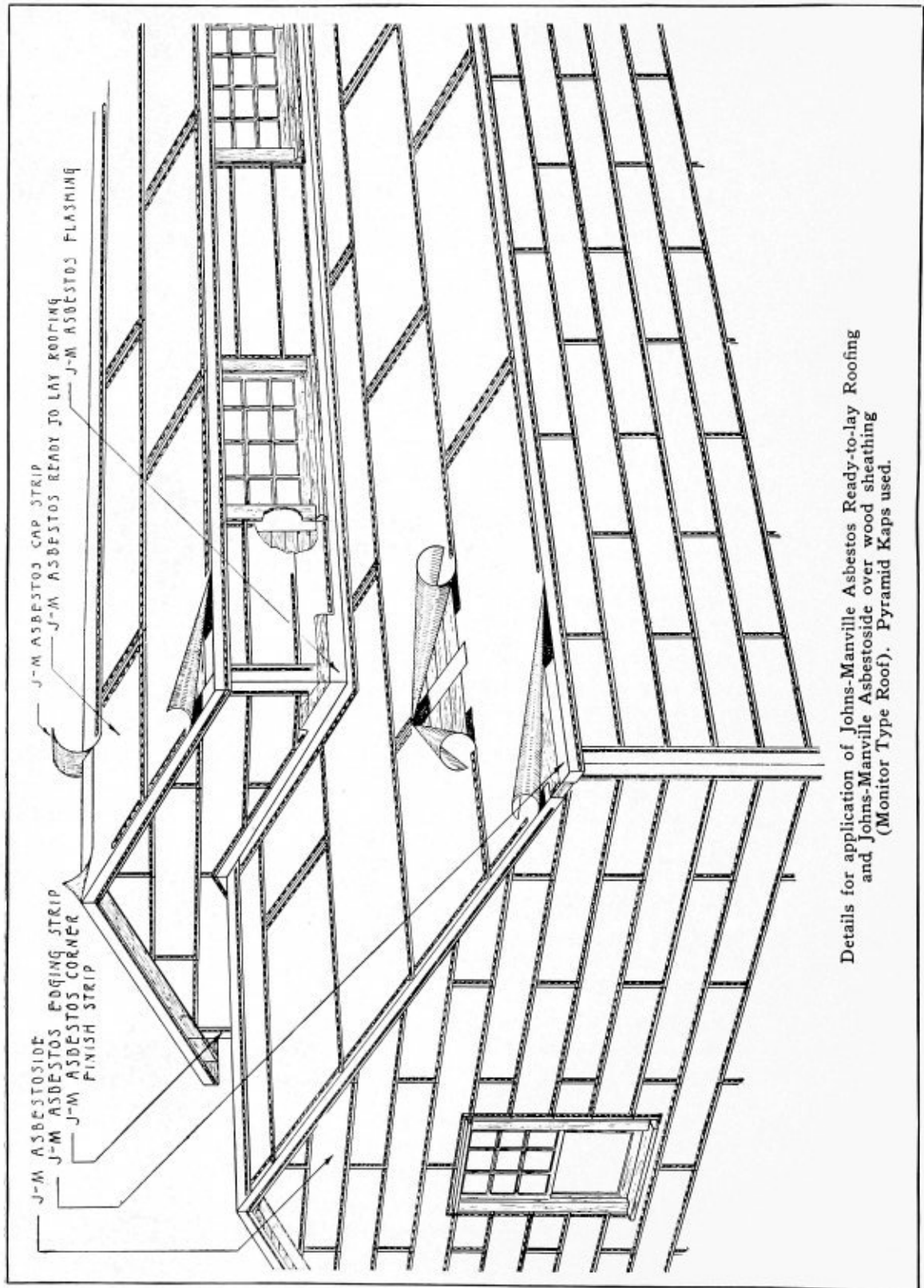

Details for application of Johns-Manville Asbestos Ready-to-lay Roofing and Johns-Manville Asbestoside over wood sheathing (Monitor Type Roof). Pyramid Kaps used.



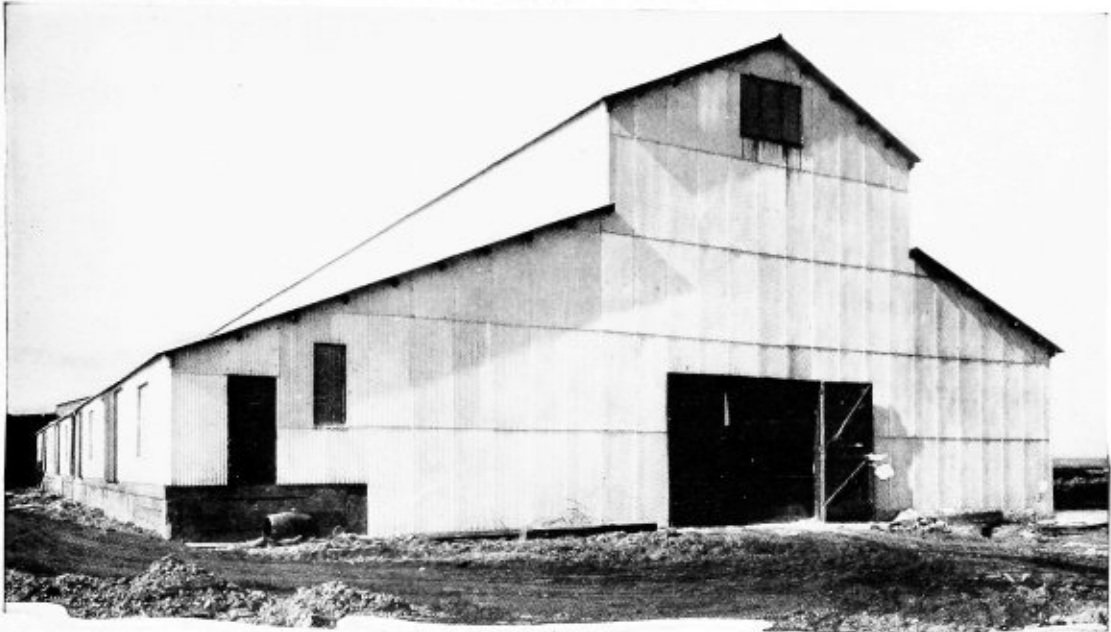

An installation for M. L. Shoemaker, Philadelphia, Pa. Note the neat gray finish and the continuous horizontal and vertical lines made possible by the special cut corner construction.

## Johns-Manville Transite Corrugated Asbestos Roofing and Siding

**A** PARTICULARLY economical, durable and fireproof roofing and siding for application directly over purlins or girts in skeleton frame construction, or over wood sheathing.

A material that will not rot, rust or burn; that never needs paint; that is immune to alkalis, gas fumes and most acids. A rigid, corrugated slab of mineral that actually grows tougher with age.

Made of Asbestos fibres and Portland cement molded under great hydraulic pressure into dense, tough, structurally

strong sheets of solid mineral. It is ideal for many conditions, particularly on low buildings over boilers and where sustained high temperatures or condensation and corrosive fumes make the use of ordinary corrugated roofing impractical and expensive. Transite Corrugated does not warp, crack or peel. It is unaffected by temperature differences. It is practically indestructible and this fact assures the longest, most economical and satisfactory service.

### Can be used on Spans up to 45 inches

Because of its unusual strength, Transite Corrugated Asbestos Roofing and Siding can be laid on spans up to 45" directly on the purlins or girts. Our en-

gineers may be able to help in making a substantial saving of structural steel where a building has not yet been erected.



## Economically, Quickly and Easily Applied

Johns - Manville Transite Corrugated Asbestos Roofing and Siding has none of the disadvantages of metal roofing, which is always liable to rust or corrode and allow water to drip in on valuable stock or machinery.

The history of a metal roof is one of expense for constant painting and patching and oftentimes, replacement. When once erected the metal sheathing cannot be painted between the laps, under flashings, or on the underside where it rests over the purlins or girts. It is at these vital points that rust starts. The metal becomes thinner and thinner and finally gets beyond repair.

The history of Transite Corrugated Asbestos Roofing and Siding, on the other hand, is one of long life, low cost and minimum upkeep expense. It never needs paint or other protection to help it keep

its original structural strength—in fact it actually grows tougher with age.

Johns - Manville Transite Corrugated Asbestos Roofing and Siding requires no special tools for application and can be installed as rapidly and in the same general way as other corrugated material. It can be readily sawed, punched or drilled and fastened with bolts, nails or screws, as shown on page 138.

The extra width of the sheets in which this material is furnished requires the handling of fewer sheets and the making of fewer laps, thus permitting a substantial saving in labor and materials as compared with ordinary corrugated roofing.

Johns - Manville Corrugated Asbestos Roofing and Siding presents a clean, neat, gray finish which lends an attractive appearance to the building.

## Where Used

Recommended for use on engine houses, boiler houses, chemical and fertilizer plants, warehouses, piers, coal bunkers, hangars, oil houses, elevators, heating plants, garages, car barns, train sheds, awnings and sheds over loading platforms, bridges between buildings, covered

bridges over tracks, or any place where roofing or siding of this type can be used.

On sawtooth roof construction it provides a maximum of light reflection into the interior of the building in addition to durability and economy.

Transite Corrugated Asbestos Roofing and Siding is made of these two indestructible minerals—*asbestos rock fibre* and *Portland cement*—combined under great hydraulic pressure. That's why it's so everlastingly durable.





## Cut Corner Construction —A Feature

A feature of this material is the manner in which sheets are butted and lapped at the corners, which is provided for by special cut corner construction. These cut corners eliminate a thickness of material where the four sheets come together in the corner lap, thus allowing the sheets to nest perfectly at these points, permitting them to be laid with laps forming continuous horizontal and vertical lines. This improves the appearance and eliminates cutting of sheets at one end of the building. The inside and outside radii of the corrugations are the same, thereby allowing the sheets to nest perfectly at all laps.

All of the foregoing features provide a more weathertight, watertight and better looking job than is possible with any similar type of roofing.

Our engineers will be glad to go over plans and discuss the use of Transite Corrugated for new buildings, or for the replacement of roofing and siding on buildings already in service.

## How Furnished

Johns-Manville Transite Corrugated Asbestos Roofing and Siding is furnished in sheets 42" wide,

### Bevel Cut Corners of Transite Corrugated Asbestos Roofing

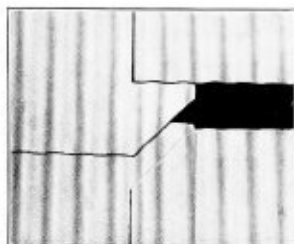

1. Corner drawn apart. Extra thickness is avoided by butting the two bevel corners instead of lapping.

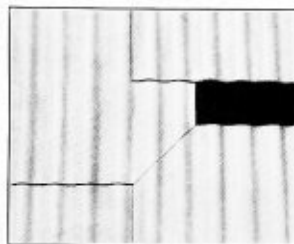

2. Upper bevel sheet moved into place. When remaining top sheet is in position, there are no crevices for the weather to enter.

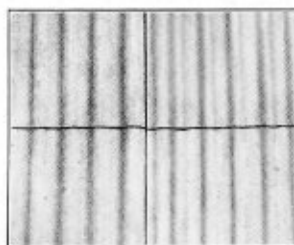

3. Complete corner. Note the vertical as well as horizontal laps form continuous straight lines, a better looking job than the customary staggered vertical lap.

and in standard lengths of 4, 5, 6, 7 and 8 ft. Sheets can be furnished, on special order, cut to any desired length possible from the above mentioned standard sizes. Comes in two thicknesses, approximately  $\frac{1}{4}$ " and  $\frac{1}{2}$ ". This material is smooth on the weather side, the other side being slightly pebbled.

## Special Curved Sheets

Where it is desired to use curved sheets, they can be furnished, on special order, curved at the factory with the following limitations; sheets may be curved longitudinally, the arc being formed along the direction of the corrugations. Minimum radius when so curved 48".

Sheets may be curved crosswise, the arc being formed across the corrugations. Minimum radius when so curved 12". Sheets may be curved either way but not in combination.

The same materials that are used in forming the corrugated sheet are moulded at the factory into special standard shapes to be used as ridge roll, corner roll, louvres and ventilators; see pages 138, 139 and 175. Flat sheets can be furnished as described on page 170. All of the above mentioned materials are particularly designed to be used in connection with the corrugated material, but can also be used independently.



Specialty designed Johns-Manville fasteners should be used in the erection of this material.

This material may be laid on roofs pitched 2" to the foot and over. Where pitches are from 2" to 4" to the foot, Johns-

Manville Asbestos Roof Putty is to be used in all laps. Where pitch is over 4" to the foot this precaution is not necessary unless extraordinary service conditions demand it.

### A Tested and Proved Material

Asbestos is a mineral that withstands all the destructive forces of nature. Portland cement is used universally in building for permanence. These materials combined in Transite Corrugated Asbestos Roofing and Siding, make the ideal material for skeleton frame construction.

This product is simply a different form of a time-tested material. It is the same as Johns-Manville Transite Asbestos Wood

which has been used in railroad and industrial construction over a period of many years as fireproof roofing and siding, partitions, walls, ceilings, in fact, anywhere a fireproof and durable material is needed.

This tested and proved material is corrugated to give greater strength thus allowing for its use as roofing and siding over widely spaced purlins.

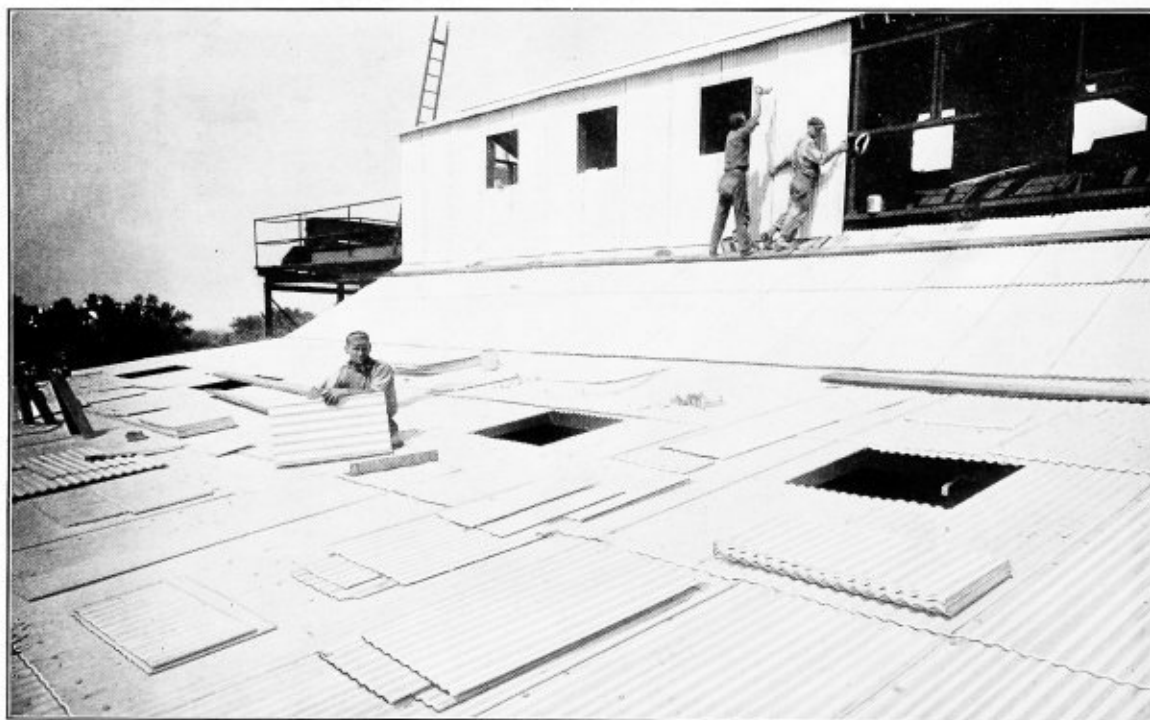

This building of the Iowa Southern Utilities Company, Centerville, Iowa, will be free from roof troubles practically as long as the structure stands. The natural gray surface of this Transite Corrugated Asbestos Roofing never needs paint or other protective coating. David F. Fisher & Co., Engineers.





## Standard Specifications for the Application of Johns-Manville Transite Corrugated Asbestos Roofing and Siding

### ROOFING AND SIDING

Where shown on plans, the roofs and sides of building shall be covered with Johns-Manville Transite Corrugated Asbestos Roofing and Siding as manufactured by Johns-Manville Inc. The material to be of a dense, homogeneous construction, weighing approximately 3.5 lbs. per square foot, and to be approximately  $\frac{5}{16}$ " thick at ridge and valley of corrugations and approximately  $\frac{1}{4}$ " thick on slope.

When  $\frac{1}{2}$ " material is to be specified cross out above data on weight and thicknesses ONLY and substitute the following:

*Weighing approximately 7 lbs. per square foot, and to be approximately  $\frac{5}{8}$ " thick at ridge and valley of corrugations and approximately  $\frac{1}{2}$ " on slope.*

Sheets shall be 42" wide and of suitable length so that all end-laps shall occur over a purlin or girt. Sheets shall be furnished with cut corners

enabling material to be laid with side laps forming vertical lines.

Sheets shall be laid with 6" end-lap and two corrugations side lap.

### FLASHING (AND BUILDING TRIM)

Where shown or indicated on plans Ridge Roll, Corner Roll, Louvers and Flashing to be of the same material as the roofing and siding. All other flashing to be of 4 lb. Sheet Lead.

### FASTENERS

Johns-Manville Standard sheradized or galvanized Fasteners shall be used. Heads of all fasteners on weather side of building shall be protected with Johns-Manville Asbestos Roof Putty.

### METHOD OF APPLICATION

The method of application shall be in strict accordance with the manufacturer's standard erection instructions.

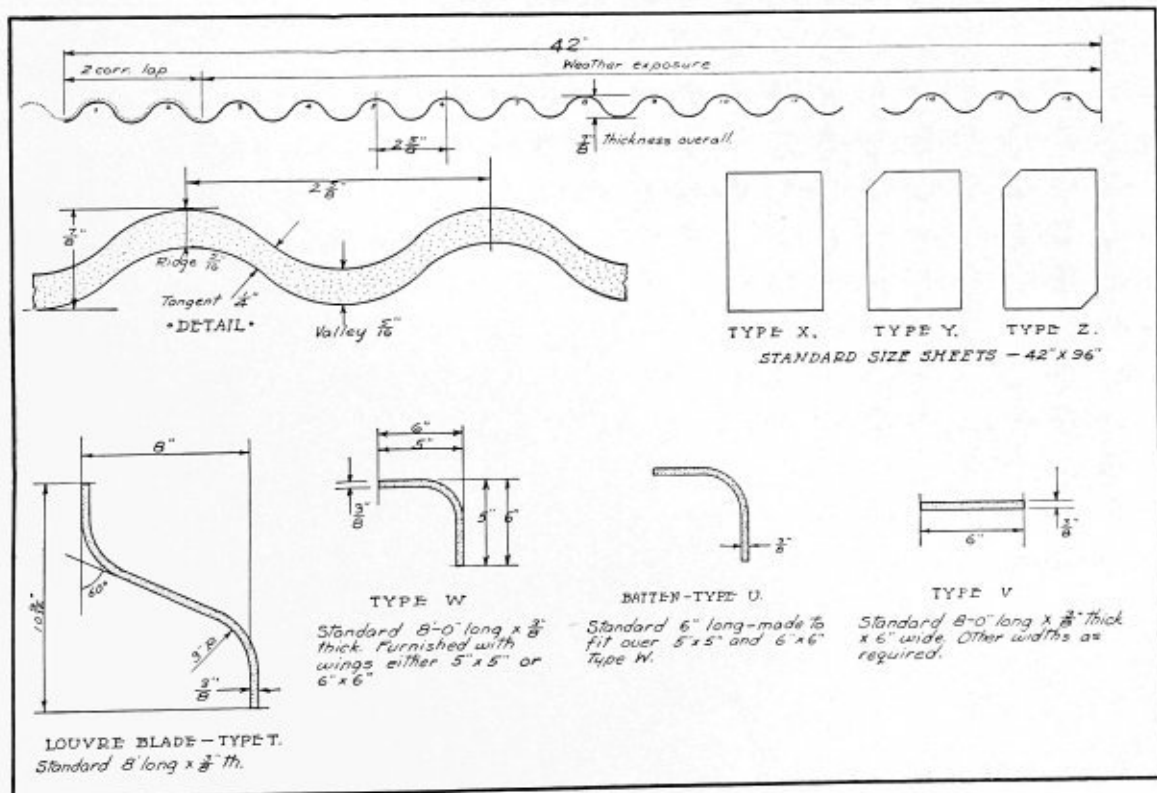

Types of Johns-Manville Transite Corrugated Asbestos Roofing and Siding, ( $\frac{1}{4}$ " thick) Louvres, Ridge Roll, etc.—Drawing AW-1.



# Johns-Manville Service to Industry

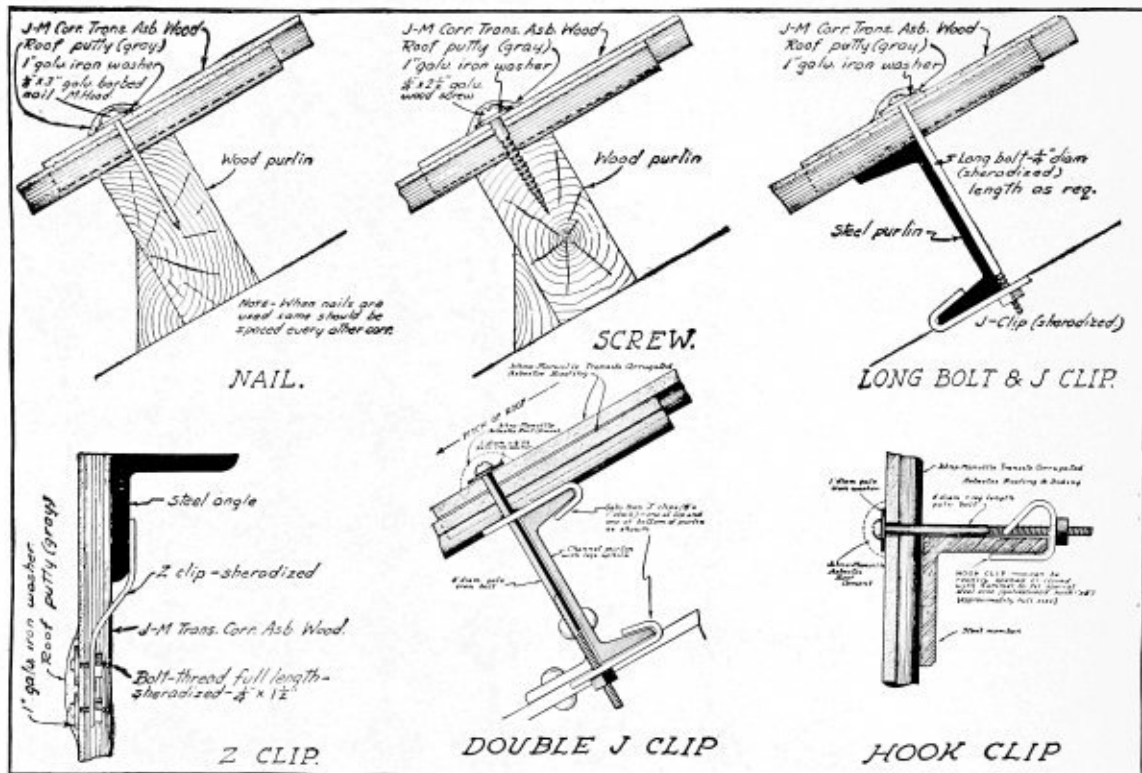

Fasteners for Johns-Manville Transite Corrugated Asbestos Roofing and Siding.  
 Drawing AW-2.

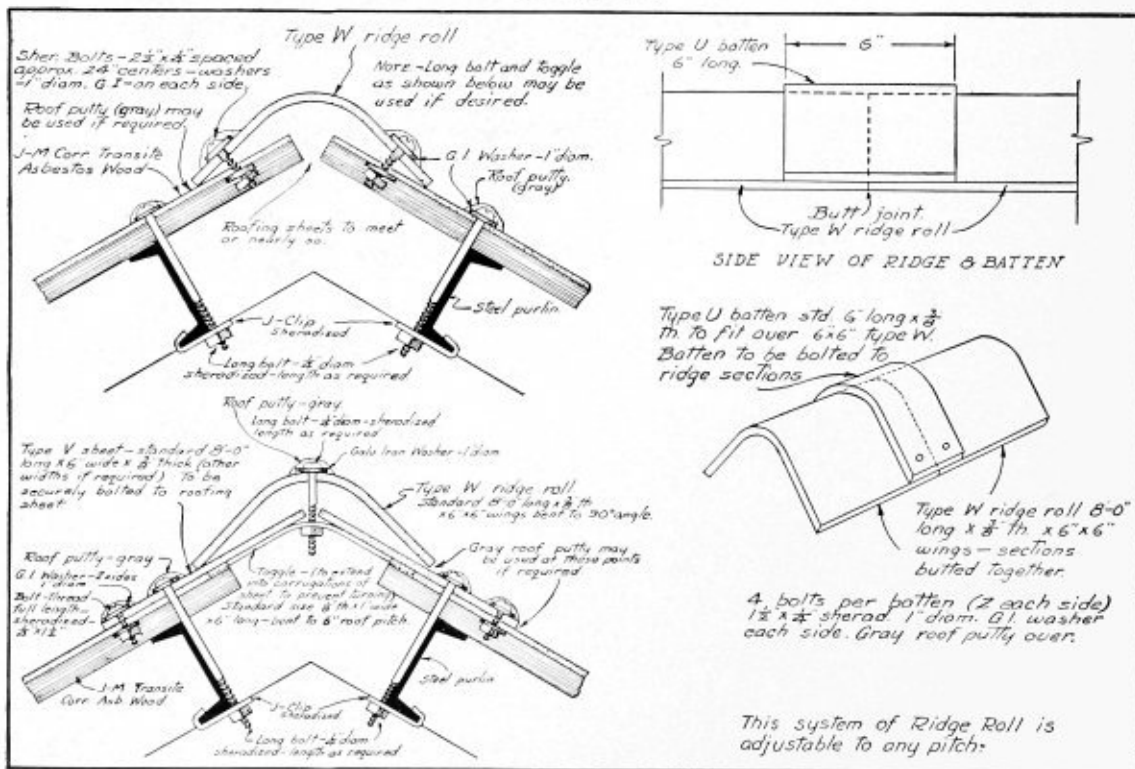

Ridge Roll for Johns-Manville Transite Corrugated Asbestos Roofing and Siding.  
 Drawing AW-3.



# Johns-Manville Service to Industry

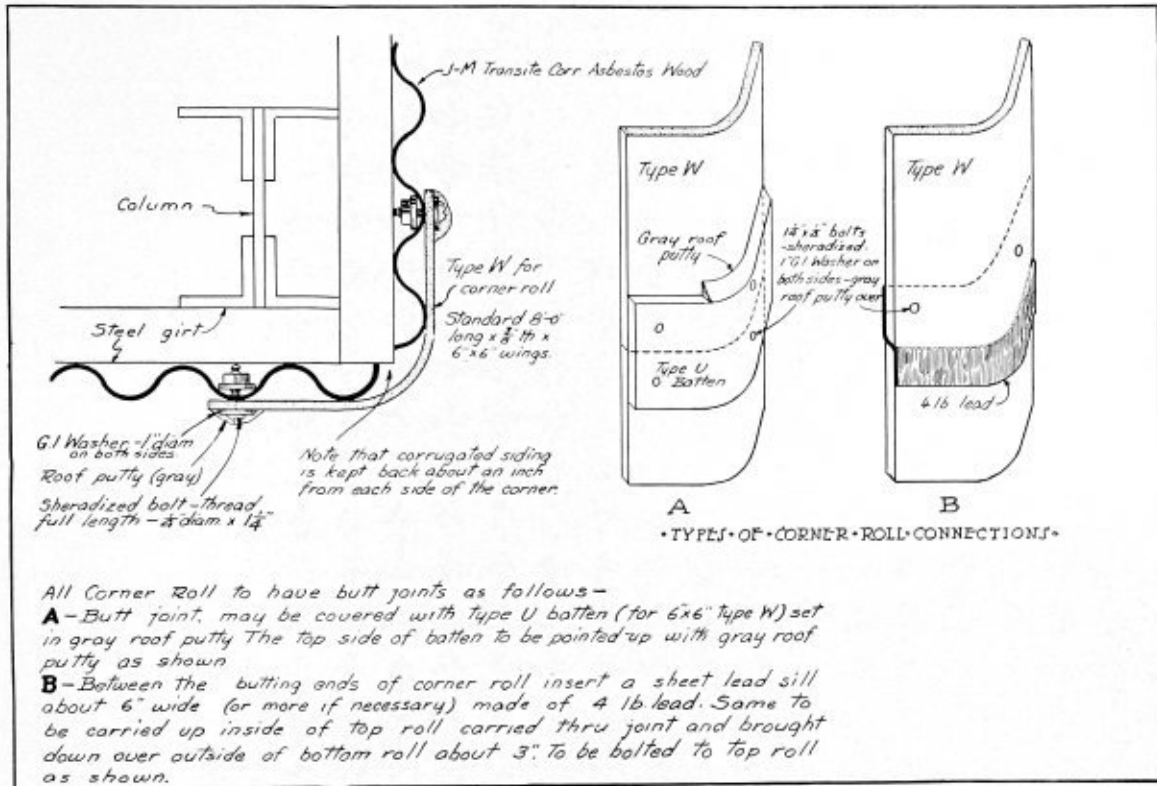

Corner Roll for Johns-Manville Transite Corrugated Asbestos Roofing and Siding. Drawing AW-4.

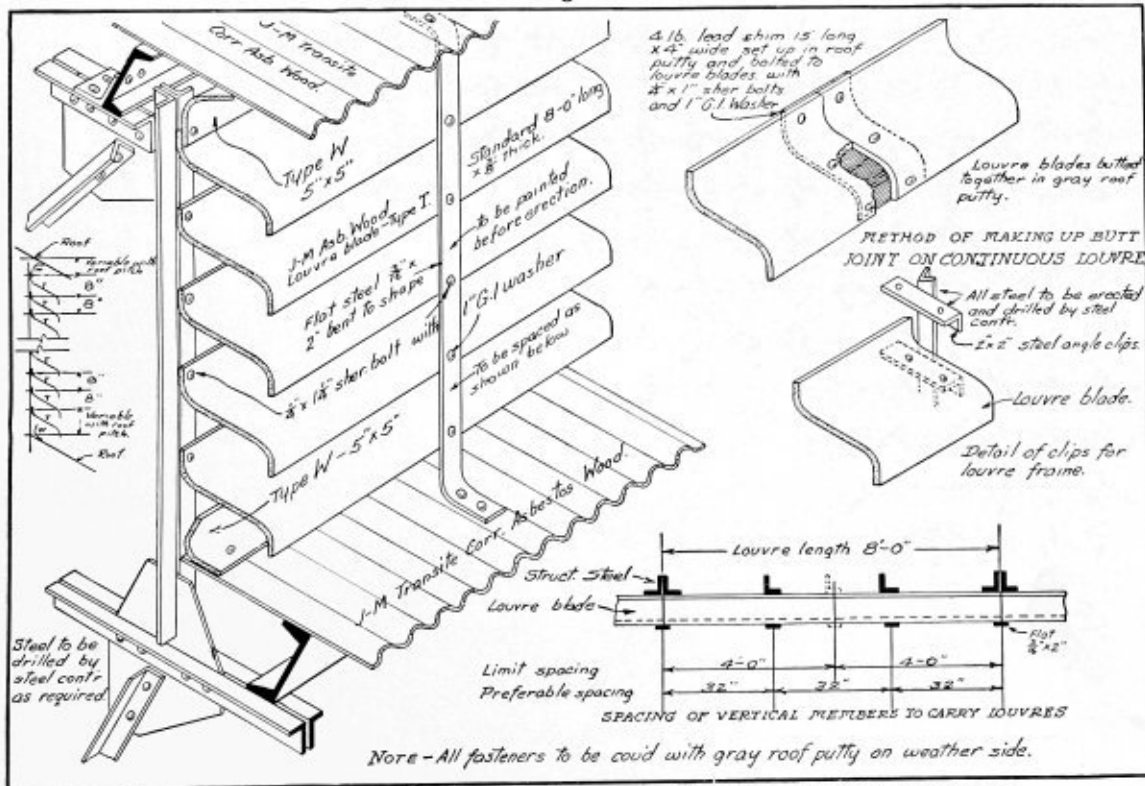

Louvres for Johns-Manville Transite Corrugated Asbestos Roofing and Siding. Drawing AW-5.



# Johns-Manville Service to Industry

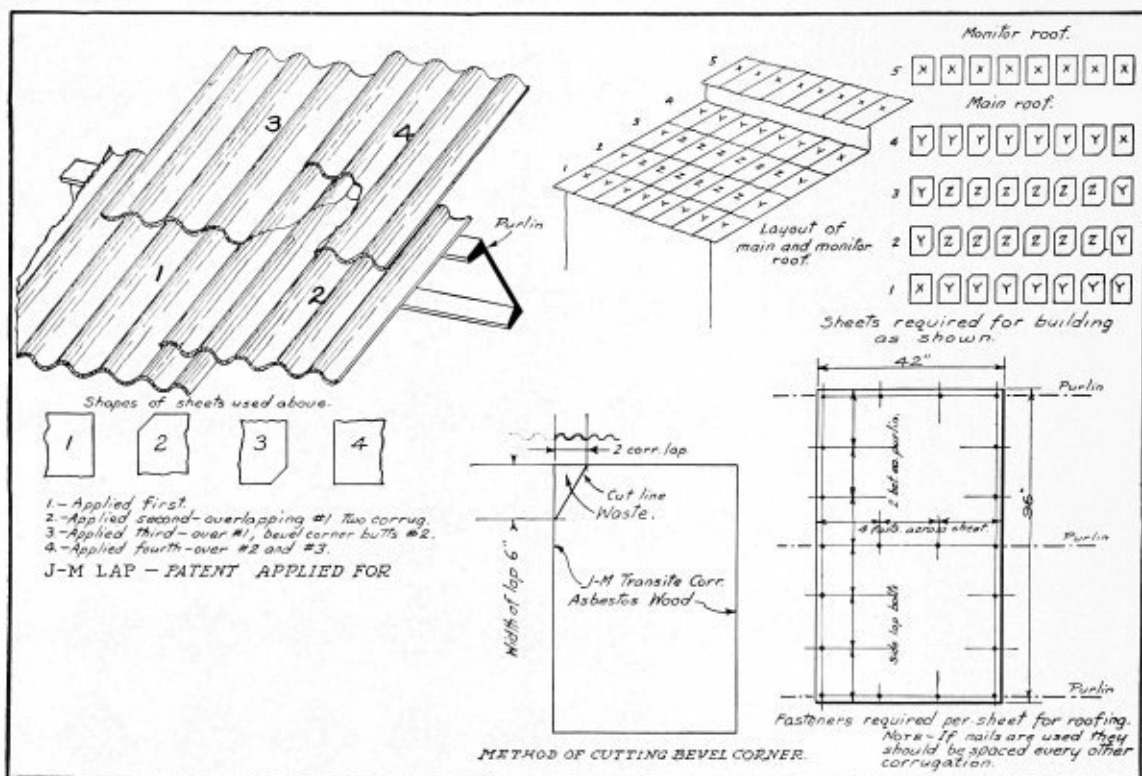

Details of Application of Johns-Manville Transite Corrugated Asbestos Roofing and Siding—Drawing AW-6.

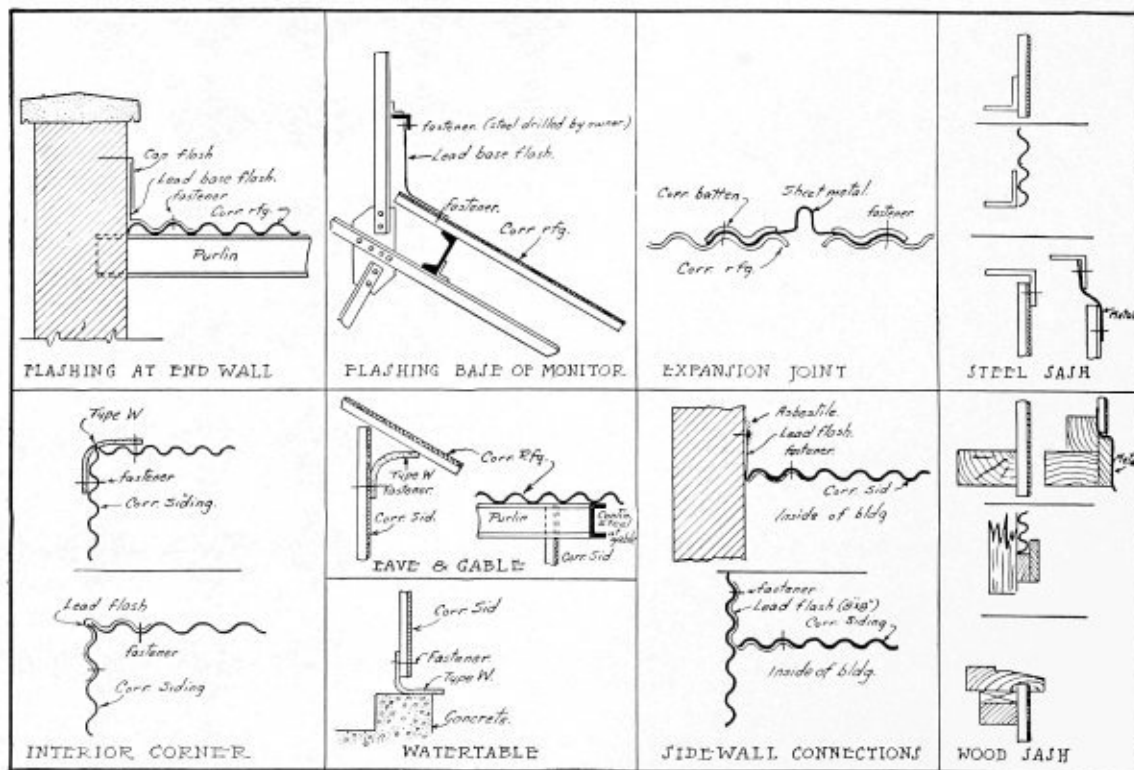

Flashing in connection with Johns-Manville Transite Corrugated Asbestos Roofing and Siding—Drawing AW-7.



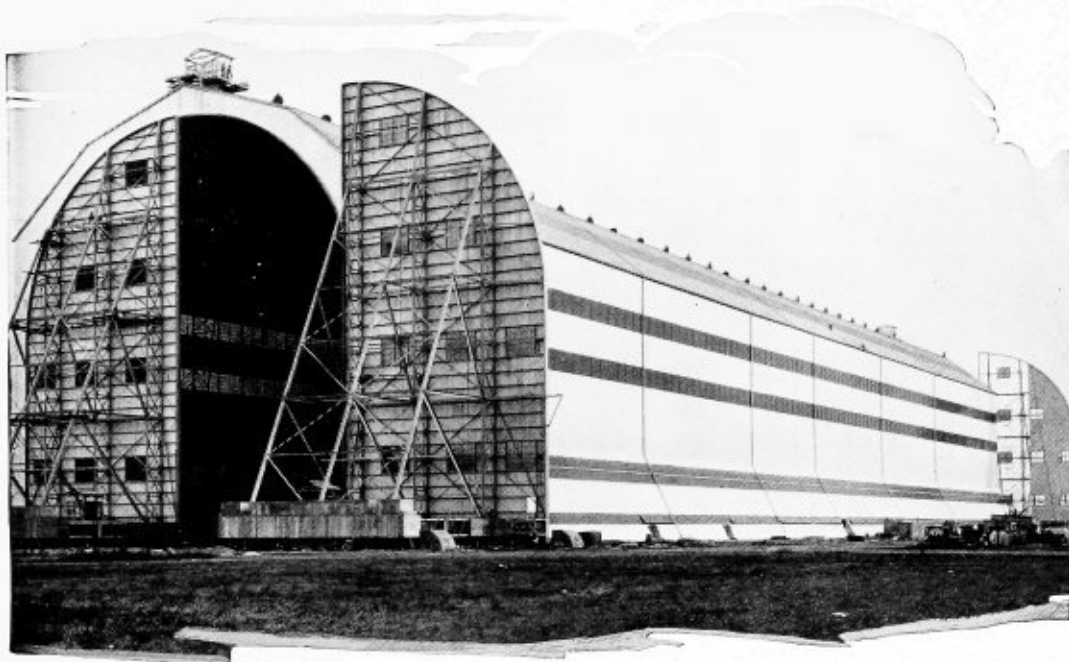

UNITED STATES GOVERNMENT BALLOON HANGAR, SCOTT FIELD, ILL.  
Erection supervised by Construction Quartermaster.

This is one of a number of balloon hangar installations on which the insulating value of Asbestos Protected Metal plays an important part and assures strength, long life and freedom from maintenance expense. The United States Government is a large and regular purchaser of this product.

## Asbestos Protected Metal Roofing and Siding

**T**HIS is another type of corrugated asbestos roofing and siding. Like Transite Corrugated Asbestos Roofing and Siding described on pages 133 to 140, Asbestos Protected Metal is intended for use over skeleton frame construction, or wood sheathing. However, these two materials are distinctly different in appearance and general characteristics. They are made of different elements and in a radically different manner.

Asbestos Protected Metal is a light, strong, permanent, acid, alkali and weatherproof building covering. It is easily handled and can be erected without regard

to weather conditions. Its long life, insulating qualities and the elimination of painting and maintenance costs effect large financial savings.

Asbestos Protected Metal combines in one product all the merits of both corrugated metal and the best built-up roofing. In effect it is a corrugated steel roof on which a perfectly made built-up roofing has been applied at the factory to both surfaces under exact heat control and exact pressure.

Asbestos Protected Metal has many times the insulating value of corrugated steel. This is the reason, as shown by ser-



vice tests, that buildings on which it is used in tropical countries are so much cooler and more comfortable to work in, as well as more attractive in appearance and more durable. As no thinners or driers are used, the coatings set up hard and tough when exposed to the sun.

In cold countries the insulation results in buildings being easier to heat than those covered with unprotected metals.

The original product has been constantly improved until today it has a number of exclusive patented features which greatly add to its quality and durability. The product is not new or untried. For many years it has stood the test of service on buildings where conditions are the most severe that can be encountered.

The foremost American, Canadian and foreign industries have used it exclusively under a great variety of conditions for new construction and for replacing other old or worn out materials. The ease and speed with which it may be erected and freedom from litter allow continuous plant operation, making it specially desirable for renewals.

### How Asbestos Protected Metal Is Manufactured

**A**SBESTOS Protected Metal is made by combining steel sheets, (of 18, 20, 22, 24 or 26 gauge) asbestos and three different asphaltic compounds, each being prepared to meet a different requirement. They are the result of seventeen years' experience, together with investigations by able engineers and chemists and by the foremost chemical research organizations. Considered from either an erection or maintenance viewpoint Asbestos Protected Metal offers building owners

permanent construction at a price that materially reduces overhead charges.

The base, or core, of Asbestos Protected Metal is a specially annealed steel sheet. The surface is thoroughly cleansed of rust, grease, moisture or any other substance that might interfere with the perfect bonding of the three protective coatings. The sheets, or shapes, are then immersed in the first asphaltic coating. When the asphaltic coatings are applied they are all heated to definite and uniform temperatures.

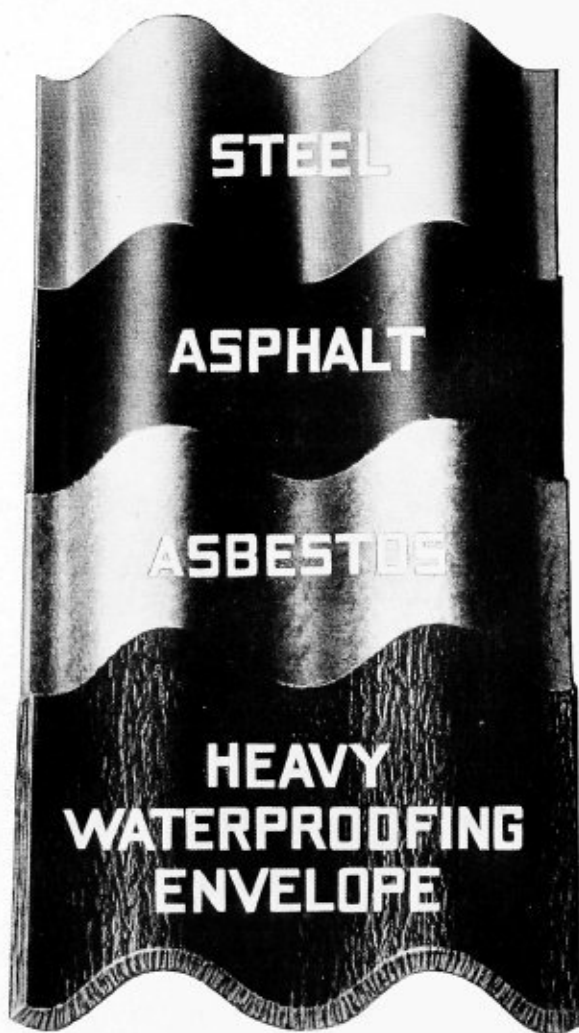

Sample of Asbestos Protected Metal with portions cut away to show relative position of the three corrosion-proof and insulating coatings with steel base or core.



The first asphaltic coating forms a thick, elastic, gas and moisture-proof shield that entirely encloses the metal. The coating is soft, the asphaltic base containing oils that help to keep it "live" and at maximum efficiency long after ordinary coatings have outlived their usefulness. This coating is then completely encased with a tough sheet of asbestos felt thoroughly impregnated with asphalt.

Specially selected asbestos fibre is used in the manufacture of this second, or middle, coating. It is made by a special process, and is so constructed that it can be impregnated with the asphalt to the best advantage.

The asphalt impregnated asbestos felt is laid over the still hot first coat and forced against it under heat and pressure in such a way that the steel, the first coat and the asphalt impregnated asbestos felt are thoroughly and permanently bonded. The felt forms an opaque insulating covering and protects the first coat from light, heat and mechanical abrasion. On the two side edges the felt is folded over and both ends are closed so that the first coat is hermetically sealed.

Finally the asbestos coating is protected from mechanical abrasion by an exclusive patented waterproofing. This waterproof coating, either black or maroon, as ordered, is applied at a high temperature to the asphalt impregnated asbestos felt forming a tough and elastic surface that allows the material to be handled freely in shipment and erection without damage to the protective coating. This coating is not affected by natural temperature changes. It is easily handled in summer, as it does not melt; and it will not chip or crack in cold weather.

Where necessary to cut sheets for building trim, ventilators, skylight metal parts, etc., all exposed edges are treated by our

special process before leaving the factory, so that no metal is exposed.

Asbestos Protected Metal can be furnished coated on both sides with aluminum paint. This finish has the limitations of other paints in wearing qualities but furnishes an excellent priming coat for succeeding paintings.

### Corrosion Proof

The great resistance of Asbestos Protected Metal to corrosion under the most severe conditions that industrial and railroad buildings encounter is important. It is impervious to moisture, salt air, mine water, condensation, acid and alkali fumes, even in combination with high humidity, coming in contact with it from either inside or outside the building. Now that the destructive force of corrosion is gaining recognition the resistance of Asbestos Protected Metal to this destructive action is becoming more appreciated.

Corrosion is sometimes called "the slow fire." Although less spectacular than fire it is now believed to cause even greater losses—and they are not covered by insurance. It is intensified by sulphuric acid, sulphurous acid, hydrochloric acid and ammonia compounds contained in soot. Wherever coal is burned these elements are created, so that plants located in "pure" country air generate their own destructive elements.

The University of Pittsburgh investigation showed losses due to the destructive action of smoke in this country each year exceeding the cost of the Panama Canal, and that if the acid content in smoke from Pittsburgh chimneys, alone, in one year acted entirely upon structural steel 265,000 tons would be dissolved.

Much of the building part of this investment loss can be prevented by the use of Asbestos Protected Metal.





## Roof Pitches

Asbestos Protected Metal corrugated sheets can be used on any roof pitch on which other corrugated sheets can be applied. Where the pitch is less than 4 inches in 12 inches both side and end laps should be laid in asphaltic cement. Corrugated sheets should not be used on roofs with a slope of less than 2 inches in 12 inches.

## Forms and Sizes

Asbestos Protected Metal is made in a variety of standard forms and sizes which good practice has demonstrated to be most useful, economical and attractive in the general run of construction work. Besides roofing and siding sheets we supply ridge caps, flashings, louvers, ventilators, skylights, made of Asbestos Protected Metal.

Corrugated Asbestos Protected Metal sheets are 27½" wide and are carried in stock lengths of even feet from 5 to 12 ft. inclusive. They have 10½ corrugations each 2⅝" wide and ½" deep. They have a net covering width of 23¾" with 1½

corrugations side lap. See drawing on page 146.

Standard Mansard sheets possess architectural advantages for both roofing and siding purposes. It is a sheet 27½" wide showing five beads, each bead measuring 2" wide by ¾" high. Sheets are made in lengths of even feet from 5 to 12 ft. inclusive with a net covering width of 24" per sheet.

Standard flat sheets are 30" wide and furnished in lengths of even feet from 5 to 12 ft. inclusive. They are also made in widths less than 30" for special purposes. They may be used for interior sheathing where desired. Also for making ventilating flues, ventilators, acid fume ducts, hoods, conveyor boxes, light partition walls, flashings, etc.

Standard fasteners for various types of construction are furnished as required.

The construction engineers at our nearest branch will be glad to go over your plans or confer with you personally on roofing or siding problems in connection with buildings of any type or size.

## Standard Specifications for the Application of Asbestos Protected Metal

### ROOFING

All roofing shall be of.....\*gauge Corrugated Asbestos Protected Metal.

Color to be { Maroon  
                  { Black

Sheets shall be laid with one and one-half corrugation side lap, and not less than 6" end lap. Manufacturer's Standard Fasteners shall be used and the method of application shall be in strict accordance with the manufacturer's Standard erection instructions. All flashings and ridge cap shall be of.....\*gauge Asbestos Protected Metal and of same color as the roofing.

### SIDING

All siding shall be of.....\*gauge Corrugated Asbestos Protected Metal.

Color to be { Maroon  
                  { Black

Sheets to be laid with one and one-half corrugation side lap and not less than 4" end lap. Manufacturer's Standard Fasteners shall be used, and the method of erection shall be in strict accordance with the manufacturer's Standard erection instructions. All flashings shall be of.....\*gauge Asbestos Protected Metal and of the same color as the siding.

\*No. 18-20-22-24 or 26 gauge depending on purlin or girt spacing. See page 145.





## Supporting Purlin and Girt Spacings

For Corrugated Sheets on roof structures having a rise of 4" or more in 12", supporting purlins may be spaced as follows:

- No. 26 gauge for spans up to 3'9" centers.
- No. 24 gauge for spans up to 4'9" centers.
- No. 22 gauge for spans up to 5'9" centers.
- No. 20 gauge for spans up to 6'6" centers.
- No. 18 gauge for spans up to 7'6" centers.

Corrugated Asbestos Protected Metal Sheets for Siding, the supporting girts may be spaced as follows:

- No. 26 gauge for spans up to 3'10" centers.
- No. 24 gauge for spans up to 4'10" centers.
- No. 22 gauge for spans up to 5'10" centers.
- No. 20 gauge for spans up to 6' 8" centers.

### WEIGHT OF ASBESTOS PROTECTED METAL IN POUNDS PER 100 SQUARE FEET OF MATERIAL AREA

ALL WEIGHTS SUBJECT TO VARIATIONS

Gauge	CORRUGATED OR MANSARD				FLAT			
	Net		For Crated Shipments Add		Net		For Crated Shipments Add	
	Black	Maroon	Domestic	Export	Black	Maroon	Domestic	Export
26	138	144	14	20	128	134	10	16
24	165	171	15	21	154	160	11	17
22	192	198	16	22	179	185	12	18
20	218	224	17	24	204	210	13	21
18	272	278	20	30	254	260	16	25

## Estimating Data—Method of Estimating Quantity

Areas of Asbestos Protected Metal Sheets may be figured by multiplying the total added length of a number of sheets by the width of a sheet.

The standard corrugated and mansard sheets are 27½ inches wide, which is 2.3 feet.

Therefore the total area of sheets given in the following example is as follows:

Number of Sheets	Length	Total Feet
30	6'0"	180
30	9'0"	270
60	10'0"	600
Total Linear Feet . . .		1050
		× 2.3
		3150
		2100

Total Material Area . . . 2415.0 sq. ft.

Standard Flat Asbestos Protected Metal Sheets are 30 inches wide, therefore the added length of a number of sheets would be multiplied by 2½.

To obtain an approximate figure on corrugated Asbestos Protected Metal required for roofs and siding add 25 per cent. to the actual building area. This takes care of all end and side laps.

It is, however, always desirable to submit sketches or blueprints so that the correct quantity and gauge of sheets, as well as flashing and fasteners can be estimated. Blueprints will be returned with our estimates, when requested.

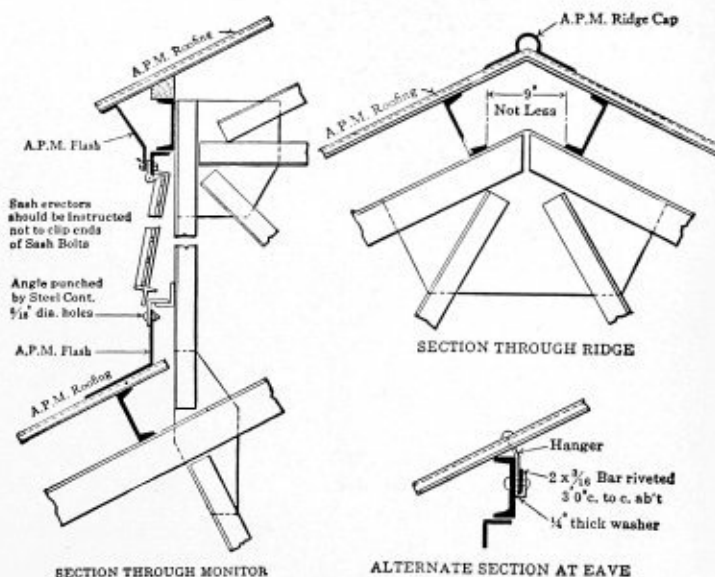



## Standard Building Details

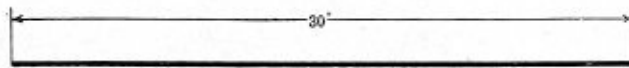

Sheet 5'-0" to 12'-0" Long  
**FLAT**  
Symbol X-1

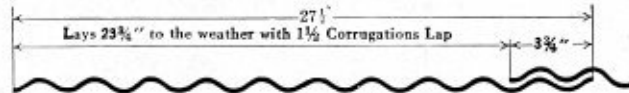

Sheet 5'-0" to 12'-0" Long  
**ROOFING AND SIDING**  
Symbol X-2

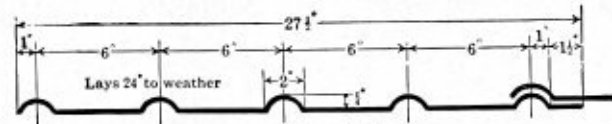

Sheet 5'-0" to 12'-0" Long  
**MANSARD**  
Symbol X-3

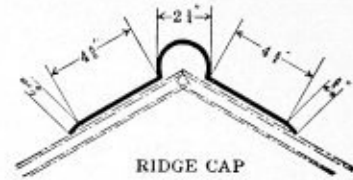

**RIDGE CAP**  
Symbol A-1

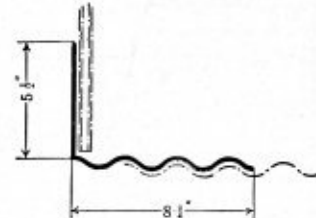

**CORRUGATED SIDE WALL FLASHING**  
Symbol A-3

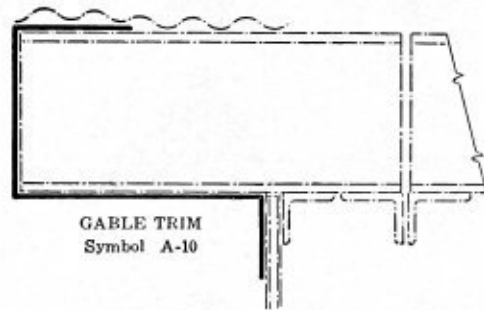

**GABLE TRIM**  
Symbol A-10

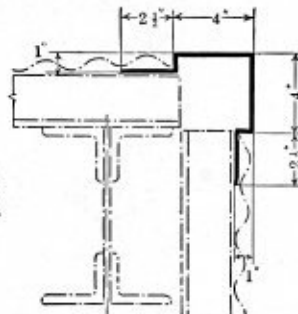

**CORNER TRIM**  
Symbol A-2

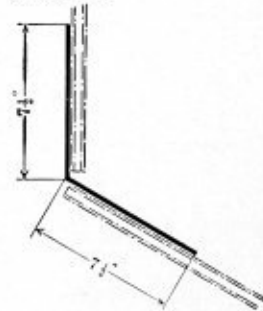

**END WALL FLASHING**  
Symbol A-4

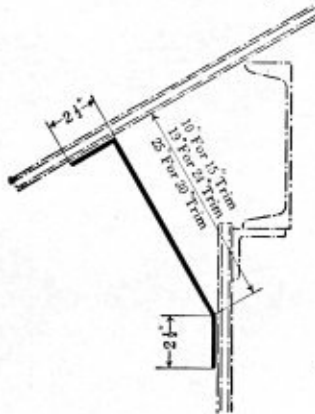

**EAVES TRIM**  
Symbol A-9

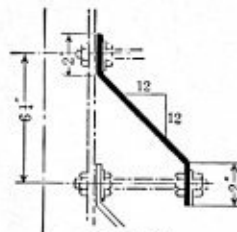

**LOUVERS**  
Symbol A-7

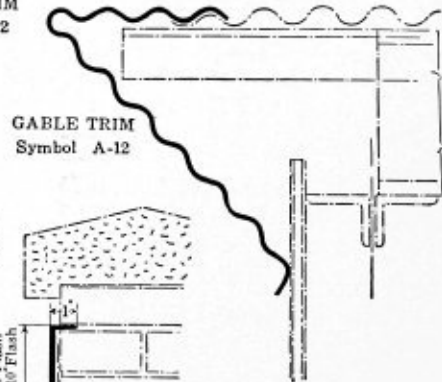

**GABLE TRIM**  
Symbol A-12

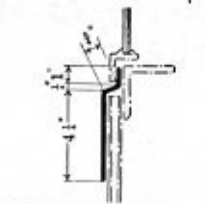

**WINDOW FLASHING**  
Symbol A-5

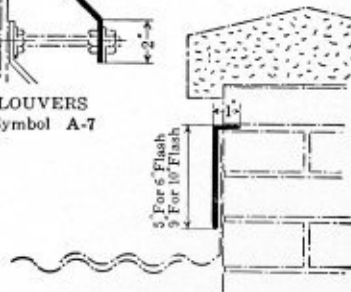

**COUNTER FLASHING**  
Symbol A-6



## Standard Building Details

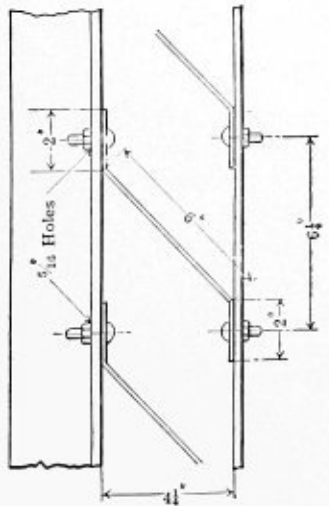
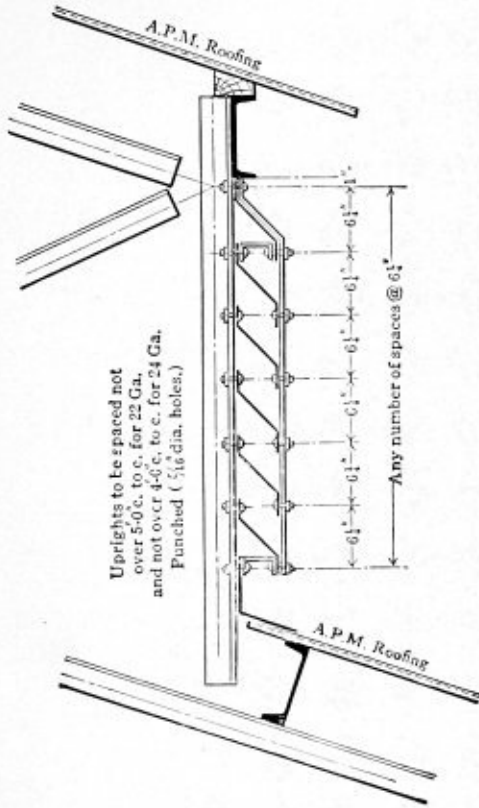

LOUVER TYPE A CONSTRUCTION

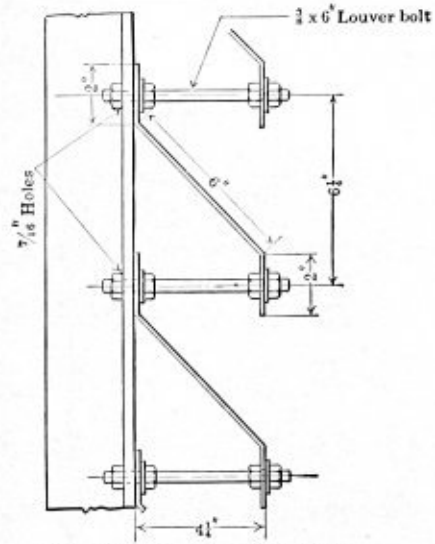

LOUVER TYPE B CONSTRUCTION

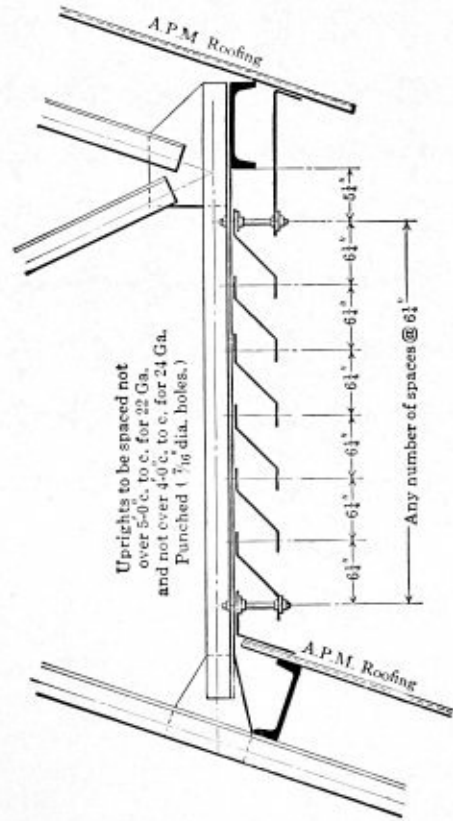

LOUVER TYPE B CONSTRUCTION



## Standard Building Details

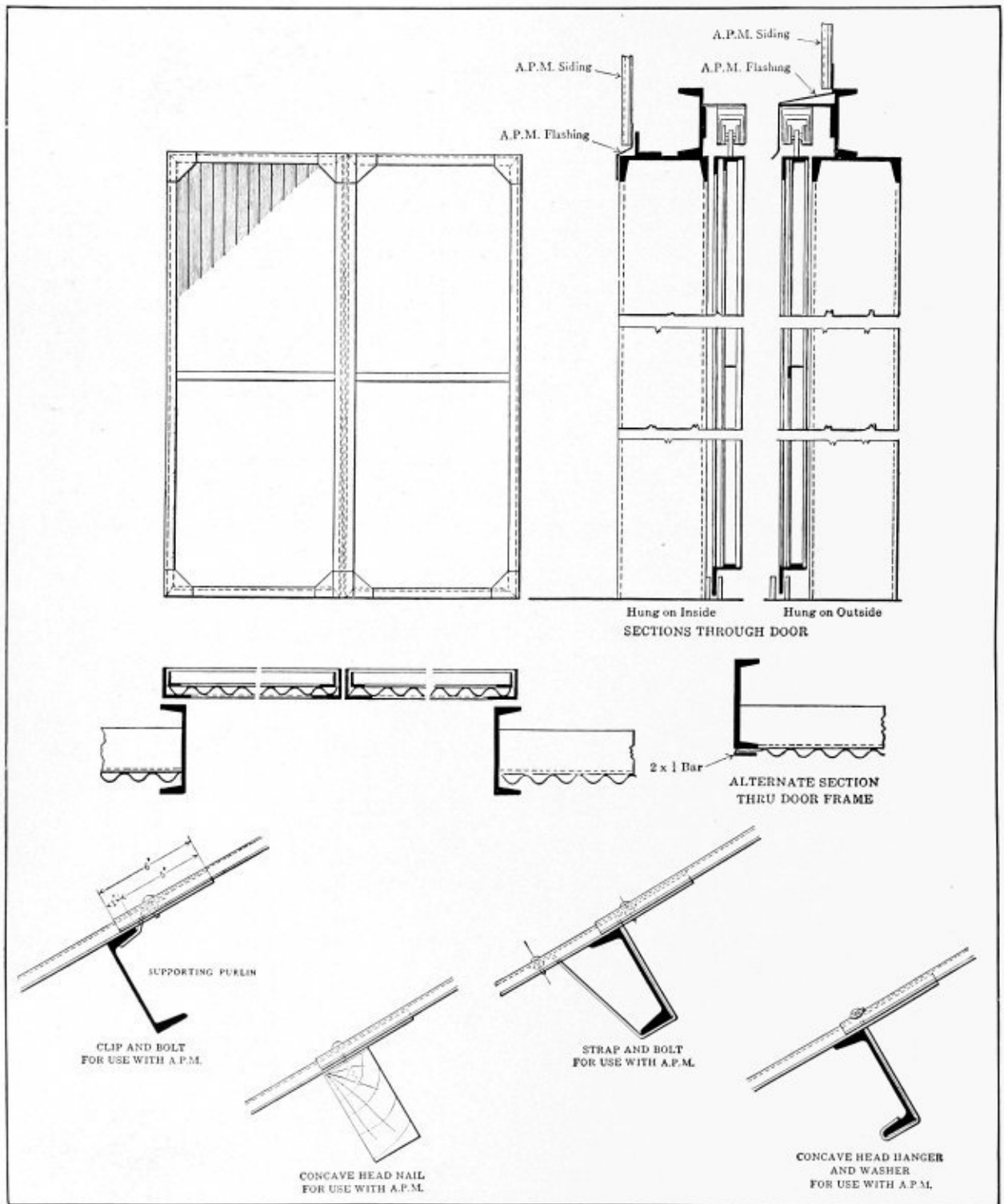



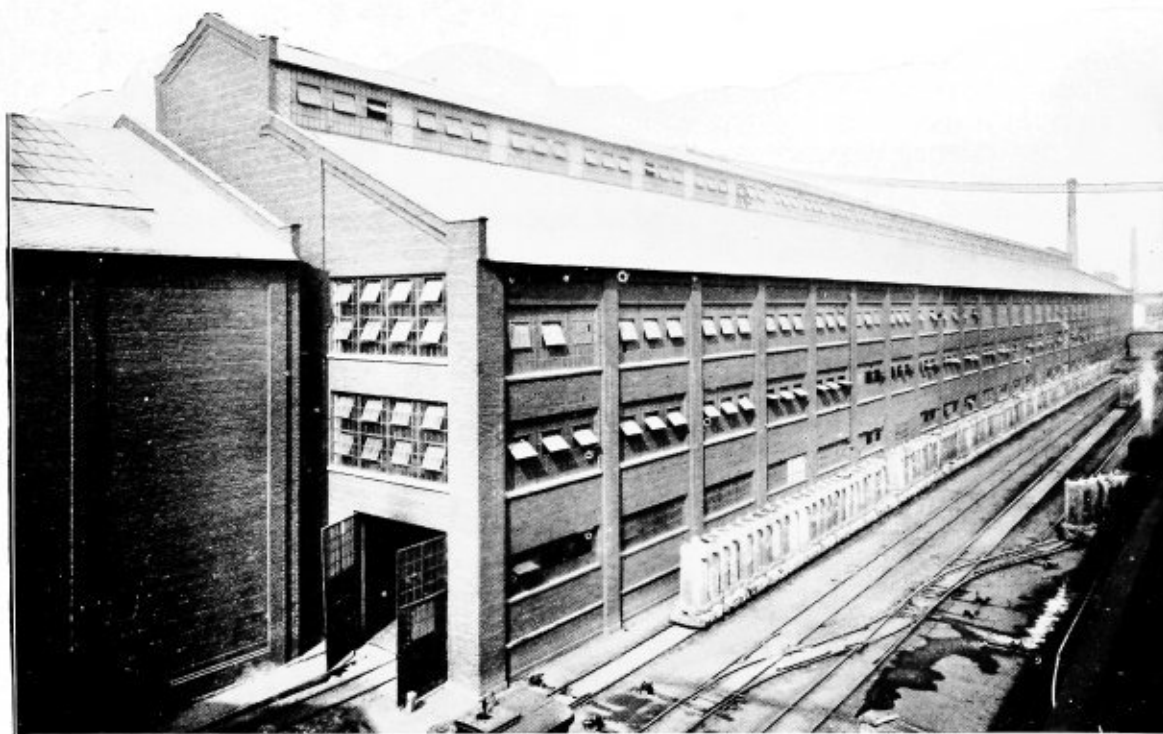

Johns-Manville Asbestos Shingles on the machine shop, store room and other buildings of the Inland Steel Co. of Indiana Harbor, Ind., have eliminated painting and similar maintenance expense. An asbestos shingle roof not only permanently protects the building from fire and weather, but enhances its appearance.

## Johns-Manville Standard and Colorblende Asbestos Shingles

**F**OR use on factory, foundry, administration, club, hotel, power houses, laboratory buildings, etc., as well as for homes and other buildings.

The use of Johns-Manville Asbestos Shingles in the industrial field has for many years been almost as general as in the field of residence construction where they have always been considered a high standard.

They offer such positive protection and afford such economy that they fill every need for a roofing material under practically all service conditions. Time and

weather have no effect upon them. They actually become tougher with age.

They are positively fireproof, which eliminates the danger of roof communicated fire and earns base rates of insurance. They do not warp, curl, shale or split. They will give the same satisfactory service year after year without repairs or replacement. They never need painting or similar maintenance which means a continuing year-by-year saving in upkeep expense.

The reason why Johns-Manville Asbestos Shingles are so durable and satisfac-



tory is because they are made of Asbestos fibre and Portland cement united under great hydraulic pressure. They cannot rot, rust or burn because they are simply a combination of rock with rock—an everlasting roofing material that lasts as long as the building it protects.

Made in a variety of sizes, shapes and colors offering a wide range of artistic and interesting roofing effects. Whether an over-all roof of red, gray or brown, obtained by the use of one of these shades, or a Colorblende effect, obtained by the use of Conglomerate Brown shingles, is desired, Johns-Manville Asbestos Shingles permit the choice of just the roofing effect desired to meet architectural, personal or other requirements.

The color plates shown on pages 153 to 156 show the wonderful artistic combinations possible with Johns-Manville Colorblende Asbestos Shingles. While it would

be seldom that such elaborate roof treatment on a factory would be desired these plates offer suggestions to plant owners, engineers and others for roofing or re-roofing their own homes. When Johns-Manville Asbestos Shingles are used for industrial buildings, generally speaking, the standard red, gray or brown shingles are selected.

They are approved by Underwriters' Laboratories, Inc., and are labeled Class A, when laid American Method and Class B, when laid Hexagonal Method. They can be applied by any roofer, slater or carpenter according to any of the various methods in vogue—American or Hexagonal on roof decks of ordinary design.

Johns-Manville Asbestos Shingles are covered by the policy of roof registration described in detail on page 110.

Construction data, drawings and detail specifications are included in this section.

### Colors, Sizes and Shapes

The color range of Johns-Manville Rigid Asbestos Shingles includes a soft Natural Gray, an Indian Red, an Autumn Brown and a composite known as Conglomerate Brown. The Conglomerate Brown blend is made up of four separate shingles each representing a different shade of brown, thus producing a subtle, pleasing blend, which can be used alone or in combination with Red or Gray. All six of these shades are made in either smooth or rough surface. The rough texture is particularly appropriate with face brick side walls or on buildings of the Spanish Renaissance type.

To the Conglomerate Brown Shingles, (either smooth or rough texture) when laid alone, or with any proportion of Indian Red or Natural Gray, the registered trade name of "Colorblende" has been given. Conglomerate Brown Shin-

gles are made in one size only, 9"x18", 1/4" thick, rough edges, No. 50 or No. 52.

The three shades, Indian Red, Natural Gray and Autumn Brown are known as Standard Asbestos Shingles and are made in 1/8" thickness with smooth edges and in 1/4" thickness with rough edges, in the sizes and shapes shown on page 158 and in the tabulation of construction data on page 151.

The Natural Gray, Indian Red and Autumn Brown Shingles, in both 1/8" and 1/4" thicknesses are not blended one with the other but are intended for use when a solid over-all roof tone of soft red, gray or brown is desired. Where a mottled or Colorblende effect is preferred the Conglomerate Brown shingles alone or mixed with Indian Red or Natural Gray should be chosen.



Johns-Manville Asbestos Shingles on a group of buildings of the H. K. Mulford Co., Vaccine Laboratories at Glenolden Farms, Pa. The durability of Asbestos Shingles, their fire protection and their freedom from maintenance assure a service satisfaction and a year-by-year saving to the user. In addition they enhance the appearance of a building and add a pleasing note of color to the roof treatment.

## Data on Johns-Manville Rigid Asbestos Shingles

Catalog Number of Main Body Shingle	Size (Ins.)	Thick-ness	Approx. Weight per 100 Shingles (Lbs.)	Approx. Weight per Sq. Applied (Lbs.)	Number Shingles per Sq.	Surface Exposed (Inches)	Galv. Nails per Sq. (Lbs.)	No. of Storm Anchors Re-quired per Sq.	No. of Sections Ridge Roll Re-quired per 100 Lin. Ft. (3" lap)	Catalog Number of Starter	No. of Starters Re-quired per 100 Lin. Ft.	Method of Laying
*3	12x12	1/8"	215	515	240	5x12	2 1/2	...	93	51 (1/4")	67	American
*4*	12x12	1/8"	205	495	240	5x12	2 1/2	...	93	51 (1/4")	67	American
*5	8x16	1/8"	185	480	260	7x8	2 1/2	...	93	51 (1/4")	67	American
*6*	8x16	1/8"	175	455	260	7x8	2 1/2	...	93	51 (1/4")	67	American
*50†	9x18	1/4"	320	650	204	8x9	2	...	93	17 (1/4")	75	American
*52†	9x18	1/4"	320	740	230	18x3 1/2	2 1/2	...	93	51 (1/4")	67†	Longitudinal
60	12x12	1/8"	200	320	160	9 1/2 x 9 1/2	1 1/2	160	93	17 (1/4")	75	Hexagonal
70	16x16	1/8"	345	300	87	13x13	1	87	93	61 (1/8")	77	Hexagonal
										17 (1/4")	75	
										71 (1/8")	58	

\* NOTE:—With this style of shingle we recommend Boston (or Chicago) Hip and Ridge; when used with No. 50 or 52 Shingles allow about 1 1/2 squares extra of No. 50 Shingles for every 100 linear feet to be covered. When used with Nos. 3, 4, 5 or 6 Shingles allow 1 1/2 squares extra of No. 5 for every 100 linear feet to be covered.

† Conglomerate Brown (blend) furnished only in the Nos. 50 and 52 Shingle sizes. No. 52 is punched and intended for application by the horizontal method (the long dimension paralleling the eaves).

\* Numbers so marked have clipped corners.

‡ Order 35 No. 51 starters and halve the long way to get the 67 starters (4 1/2" x 18").



## For Re-Roofing Over Old Wooden Shingles

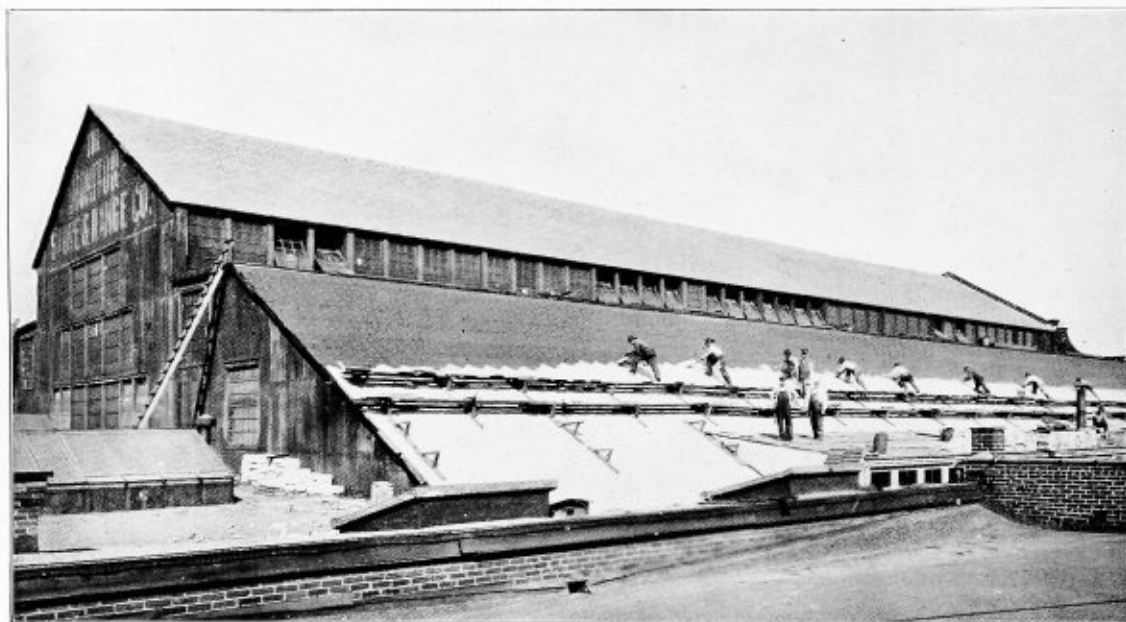

In re-roofing this plant of the Monitor Stove & Range Co., Cincinnati, Ohio, time and expense was saved and the dirty job of ripping off the old roof was avoided. The building is positively protected from roof-communicated fire. Painting and similar roofing maintenance has been eliminated and the building has been re-roofed for the last time.

**A**N old shingle or felt roof is a decided liability, not only on account of the fire hazard but the constant painting and repairs which it requires.

When it must be replaced the work can be done for the last time, and time, money and labor saved in the operation by the application of Johns-Manville Asbestos Shingles.

No longer is it necessary to rip off the old shingles. All the dust, dirt and delay can now be eliminated because the old shingles can be left just as they are and Johns-Manville Asbestos Shingles applied right on top of them.

This is the quick, clean, economical and permanent way to re-roof. It quickly transforms a dilapidated shingle roof that is a constant menace into one that is

positively fire-safe and good looking—permanent and economical.

Another advantage is that the retention of the old shingles provides a double roof which makes a building cooler in summer and warmer in winter.

When it comes to the replacement of an old shingle roof on any building apply Johns-Manville Standard or Colorblende (Rigid) Asbestos Shingles right over the old ones. The building will be re-roofed for the last time and permanently protected from fire and the elements.

Over old shingles as well as on new roofs Johns-Manville Rigid Asbestos Shingles are given highest ratings by Underwriters' Laboratories, Inc; Class A for the American method and Class B for the Hexagonal.





---

*THIS fireproof roof of Johns-Manville "Colorblende" Asbestos Shingles makes a pleasing contrast to the walls of red brick and white mortar.*

*The varied combinations in which these shingles can be laid offer many pleasing effects for every type of building where a colorful roof is desired.*

---





---

*ANOTHER* colorful roof of the fireproof, weatherproof, practically indestructible Johns-Manville "Colorblende" Asbestos Shingles.

*The riot of color in the planting is admirably topped off by the subtle shadings of the "Colorblende" roof—one which will please the most exacting.*

---





---

***B**UILDINGS covered with Johns-Manville "Colorblende" Asbestos Shingles are distinctive because of the beauty of color of their roofs.*

*When, also, the endurance and fire-safety of "Colorblende" Shingles are considered they become doubly desirable when building for permanence.*

---



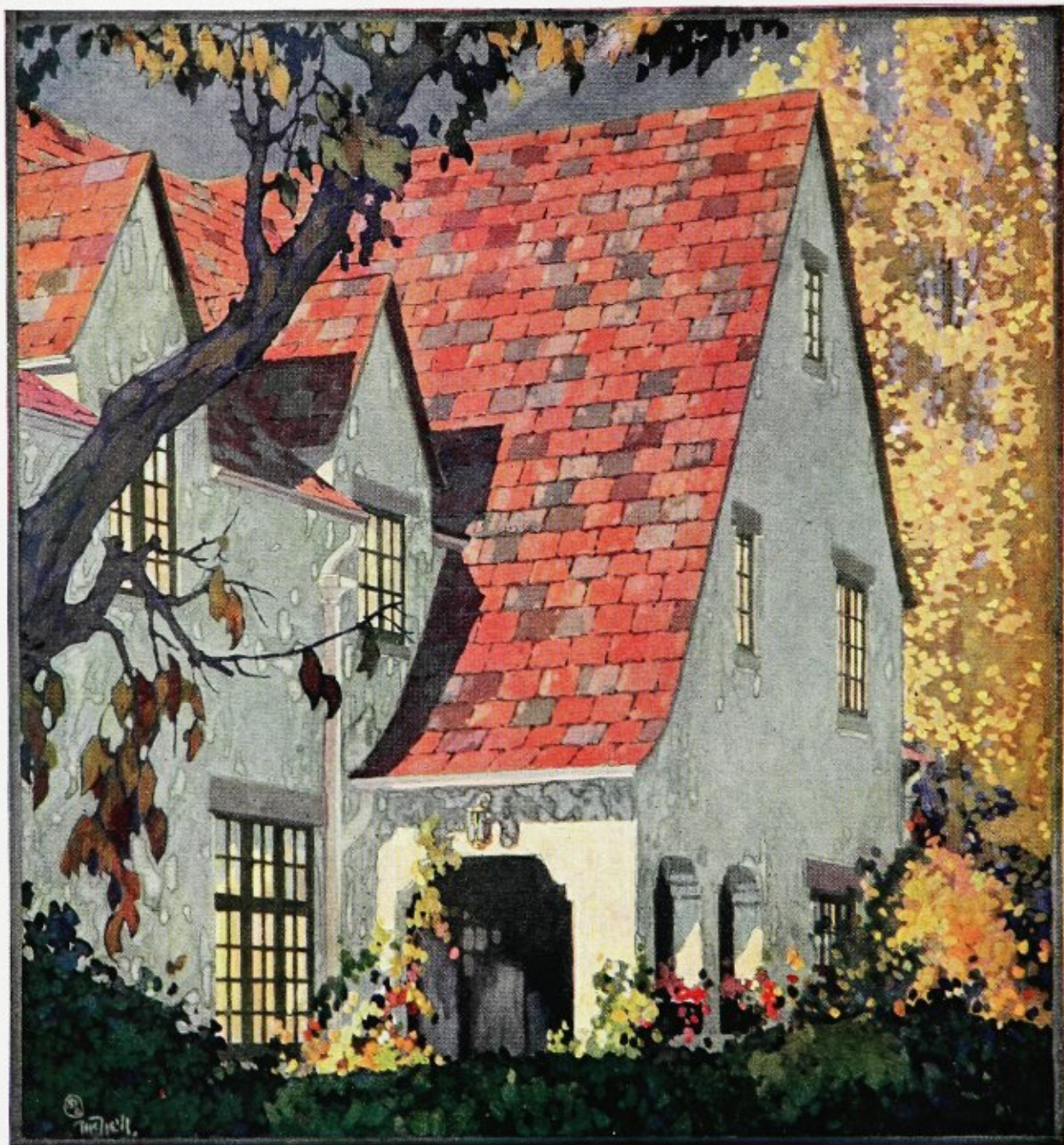

---

*HERE* the plain severeness of stucco walls is relieved by the lively color of a roof of Johns-Manville "Colorblende" Asbestos Shingles.

*These everlasting shingles are made with either smooth or rough surface texture, as suits the individual taste or particular architectural scheme.*

---





## Details of Application of Johns-Manville Asbestos Shingles

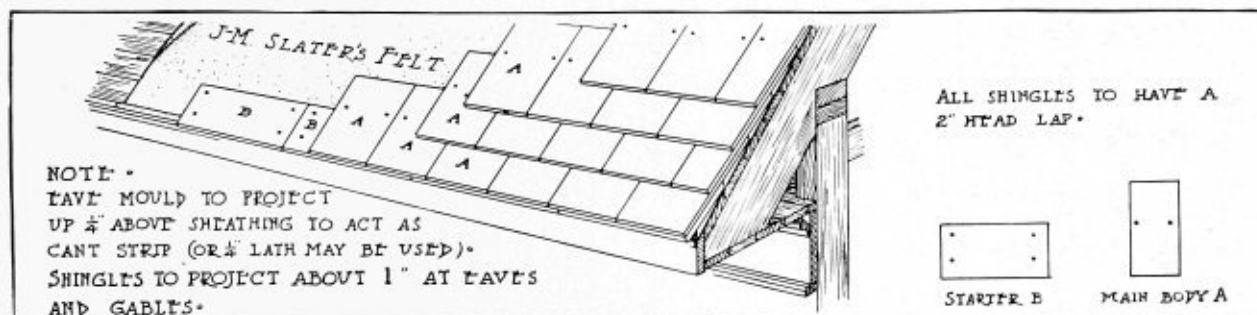

Sketch showing application of Johns-Manville Asbestos Shingles,  
American Method.

NOTE:-The sketch is correct in detail for the application of No. 5 and No. 6, 8" x 16". Where the No. 50, 9" x 18" shingle is to be applied No. 17 is the first starter, followed by No. 51 as a second starter, outlined in specification at top of page 159.

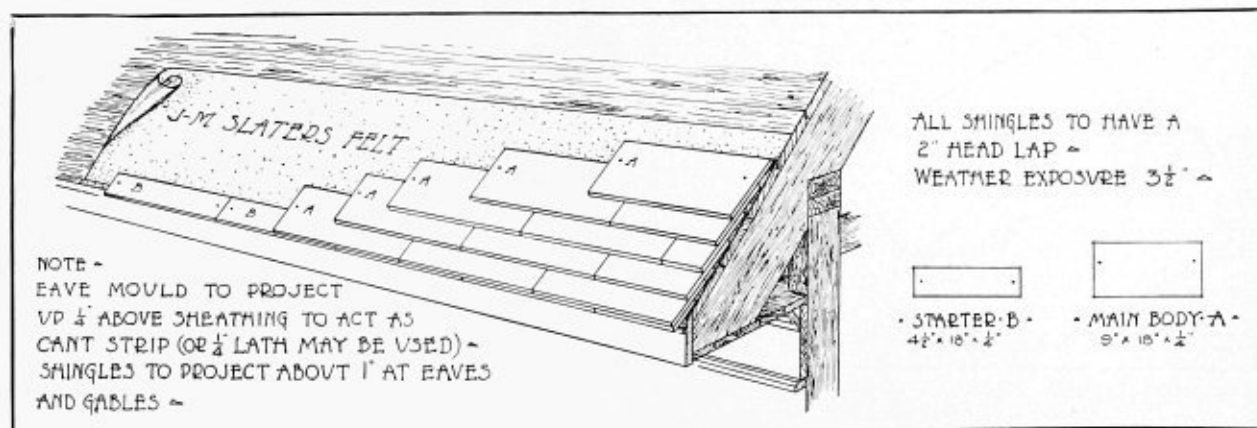

Sketch showing application of Johns-Manville Asbestos Shingles,  
Horizontal Method.

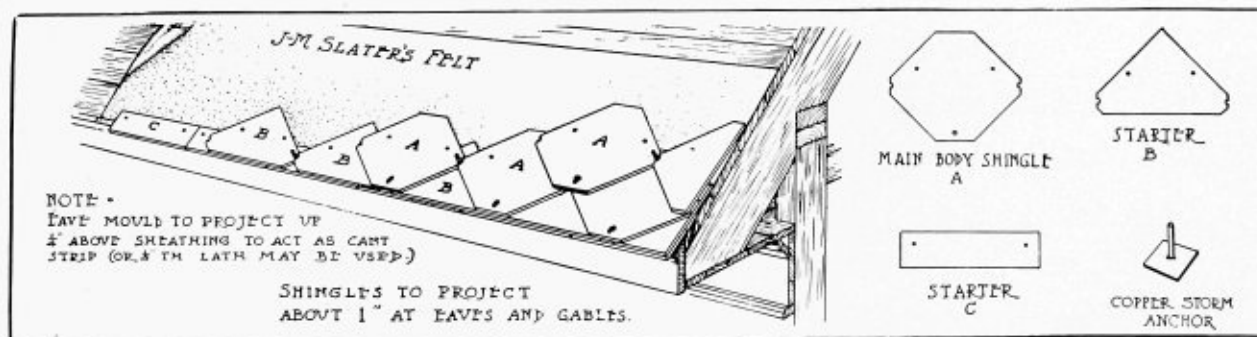

Sketch showing application of Johns-Manville Asbestos Shingles,  
Hexagonal Method.



## Details of Johns-Manville Asbestos Shingles

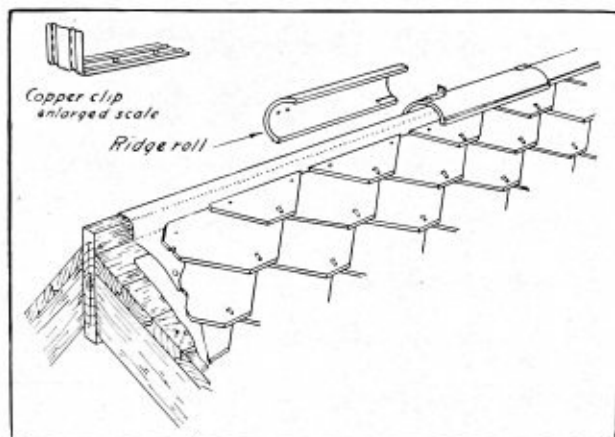

Hexagonal Shingle on roof.

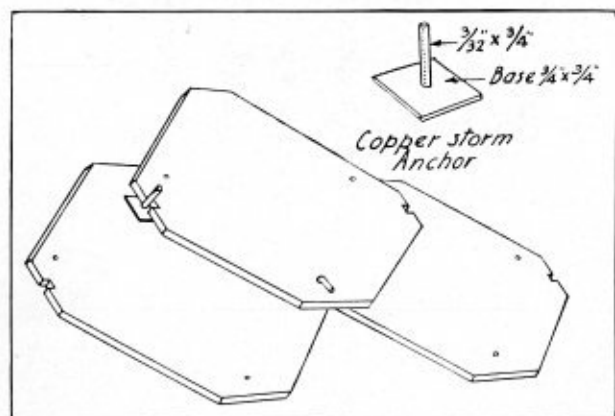

Hexagonal Shingle—Showing Application of Storm Anchor. Enlarged Scale.

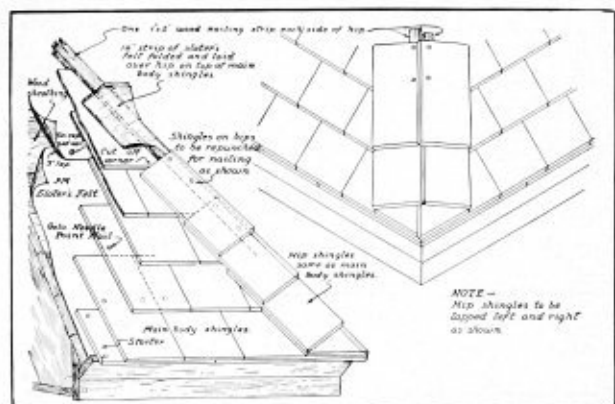

Method of laying (Boston or Chicago) Hip in connection with Asbestos Shingles. (American Method.)

### Main Body Shingles



No. 3  
12 x 12



No. 4  
12 x 12



No. 5  
8 x 16



No. 6  
8 x 16



No. 50  
9 x 18 x 7/8



No. 52  
9 x 18



No. 60—12 x 12  
No. 70—16 x 16

### Starters



No. 11—13 x 18  
No. 14—9 1/2 x 13 1/2



No. 51—9 x 18  
Rough Edge



No. 17  
4 x 16 x 7/8



No. 61—15 1/2  
No. 71—20 3/4

### Standard Shapes



## Specifications for the Application of Johns-Manville Standard and "Colorblende" Asbestos Shingles

### American Method

"Colorblende"\* Asbestos Shingles (No. 50, 1/4" thick, rough edge)

Lay roof boards in the usual manner, breaking joints and nailing securely in place with at least two nails at each rafter, leaving no loose ends. The roofing boards shall be well seasoned, of narrow width and uniform thickness; tongue and grooved preferred. Over the roofing boards lay one thickness of Johns-Manville Asbestos Slaters' Felt, laying horizontally with a 4" lap, and with 12" lap on ridges, hips and valleys. (See detail on page 157.)

Apply 1/4" thick x 1 1/2" wide furring strip parallel with and flush with the eaves, then apply one course of Standard (Brown)\* No. 17, 4" x 16" Starters, at eaves lengthwise and parallel to same, overhanging the eaves about 1". Apply second starter course using Standard (Brown)\* No. 51, 9" x 18" Starters, at eaves lengthwise and parallel to same, breaking joints with and entirely covering the first starter course. Then apply first main body course using Conglomerate Brown\* No. 50, 9" x 18", and (Indian Red\* No. 50, 9" x 18") (Nat-

ural Gray\* No. 50, 9" x 18") (mark out color not to be considered) Johns-Manville Asbestos Shingles, breaking joints with and entirely covering the starter courses; after which proceed in the regular manner as with wooden shingles or slate, exposing 8 inches to the weather and fastening each shingle in place with two galvanized iron (or copper) needle pointed shingle nails. Never drive the nails down tight; it is only necessary to drive them firmly.

The various shades of "Colorblende"\* Asbestos Shingles shall be laid at random.

#### HIPS AND RIDGES

Construct "Boston" (or "Chicago") Hip and Ridge using No. 50 Johns-Manville Asbestos Shingles—(color to be as selected).

#### FLASHINGS

Flash all chimneys, valleys, etc., with copper or other approved material.

### American Method

(Shingles Laid Horizontally)

"Colorblende"\* Asbestos Shingles (No. 52, 1/4" thick, rough edge)

When this specification is used, begin it by repeating the first paragraph, regarding the roof deck, of the specification above, continuing as follows:

Apply 1/4" thick x 1 1/2" wide furring strip parallel with and flush with the eaves, then apply one course of (Brown) 4 1/2" x 18" starters, (these to be made on the job from No. 51, 9" x 18" starters) at eaves lengthwise and parallel to same, overhanging the eaves about 1". Then apply first main body course using Conglomerate Brown\* No. 52, 9" x 18", and (Indian Red\* No. 52, 9" x 18") (Natural Gray\* No. 52, 9" x 18") (mark out color not to be considered) Johns-Manville Asbestos Shingles breaking joints with and entirely covering the starter course; after which proceed in the regular manner as with wooden shingles or slate,

exposing 3 1/2" to the weather and fastening each shingle in place with two galvanized iron (or copper) needle pointed shingle nails. Never drive the nails down tight, it is only necessary to drive them firmly.

The various shades of "Colorblende"\* Asbestos Shingles shall be laid at random.

#### HIPS AND RIDGES

Construct "Boston" (or "Chicago") Hip and Ridge using No. 50 Johns-Manville Asbestos Shingles—(color to be as selected).

#### FLASHINGS

Flash all chimneys, valleys, etc., with copper or other approved material.

\*When Johns-Manville (1/4") Asbestos Shingles are to be laid in one color, omit the word "Colorblende" in the above specifications. Insert the desired color where required.



## Specifications

(Continued)

*In the following specifications reference is made to definite sizes and styles of shingles. Where other sizes and styles are to be specified, insert color, size, style number and weather exposure as desired. (See pages 151 and 158 for necessary data.)*

### American Method

*Standard Asbestos Shingles (No. 3, No. 4, No. 5 or No. 6, 1/8" thick, smooth edge).*

Lay roof boards in the usual manner, breaking joints and nailing securely in place, with at least two nails at each rafter, leaving no loose ends. The roofing boards shall be well seasoned, of narrow width and uniform thickness; tongue and grooved preferred. Over the roofing boards lay one thickness of Johns-Manville Asbestos Slaters' Felt, laying horizontally with a 4-inch lap, and with 12-inch laps on ridges, hips and valleys.

Apply 1/4-inch thick by 1 1/2-inch wide furring strip parallel with and flush with eaves, then apply one course of No. 51 \*(B), 9 x 18 inch starters at eaves lengthwise and parallel to same, overhanging the eaves about 1 inch. Then apply first main body course using No. 5 \*(A) shingle, breaking joints with and entirely covering starter course; after which proceed in the regular man-

ner as with wooden shingles or slate, exposing 7 inches to the weather and fastening each shingle in place with two galvanized iron (or copper) needle pointed shingle nails. Never drive nails down tight, it is only necessary to drive them firmly.

#### HIPS AND RIDGES

Over the ridges and hips apply Johns-Manville Asbestos Ridge and Hip Roll with not less than 3-inch lap, fastened in place with special ridge roll fasteners, or construct "Boston" (or "Chicago") Hip and Ridge, using No. 5 shingles.

#### FLASHINGS

Flash all chimneys, valleys, etc., with copper or other approved material.

### Hexagonal Method

*Standard Asbestos Shingles (Nos. 60 or 70, 1/8" thick, smooth edge).*

Lay roof boards in the usual manner, breaking joints and nailing securely in place with two nails at each rafter, leaving no loose ends. The roofing boards shall be well seasoned, of narrow width and uniform thickness; tongue and grooved preferred. Over the roofing boards lay one thickness of Johns-Manville Asbestos Slaters' Felt, laying horizontally with a 4-inch lap, and with 12-inch lap on ridges, hips and valleys.

Apply a 1/4-inch thick by 1 1/2-inch wide furring strip parallel with and flush with eaves, then apply one course of No. 17 \*(C) starters at eaves lengthwise and parallel to same, overhanging the eaves about 1 inch. Apply second starter course using No. 61 \*(B) shingles at eaves lengthwise and parallel to same, breaking joints with and entirely covering the first starter course. Insert copper storm nails between abutting ends of shingles of second starter course.

Cover balance of roof with No. 60 \*(A) 12"x12", Johns-Manville Asbestos Shingles with copper storm nails protruding through hole in lower corner; these shingles to be laid with their side edges

forming a 45 degree angle with the eaves. Bend down copper storm nail protruding through the shingle, insert copper storm nails between abutting corners of shingles and securely fasten each shingle in place with two galvanized iron (or copper) needle pointed shingle nails. Never drive nails down tight; it is only necessary to drive them firmly.

#### HIPS AND RIDGES

Over the ridges and hips apply Johns-Manville Asbestos Ridge and Hip Roll, with not less than 3-inch lap, fastened in place with special ridge roll fasteners.

#### FLASHINGS

Flash all chimneys, valleys, etc., with copper or other approved material.

#### DIAGONAL METHOD

The Diagonal Method (No. 9 or 12) Asbestos Shingles are applied in the same manner as specified for the Hexagonal Method. The foregoing specification will apply by substituting the desired size and style number.

\*Refer to sketches on pages 157 and 158 for identification of alphabetical references.





Flexstone Asbestos Shingles afford better service and greater fire protection because of their all-mineral, asbestos rock fibre felt base.

## Johns-Manville Flexstone Asbestos Shingles (Slate Surfaced)

**W**HERE for any reason the architect prefers a flexible, slate surfaced shingle Johns-Manville Flexstone Asbestos Shingles are recommended for any size of building with a roof pitch sufficient to accommodate this type of roof covering.

Flexstone Asbestos Shingles are an improved, all-mineral form of the flexible

slate surfaced shingle. There are two types of flexible slate surfaced shingles on the market today. One is the so-called asphalt shingle and the other is the Johns-Manville Flexstone Asbestos Shingle. Although quite the same in surface appearance, the Johns-Manville Flexstone Asbestos Shingle is radically different and more desirable because of the basic raw material of which it is made.

### Flexstone Asbestos Shingles are Rock — Not Rags

In a modern sky-scraper the strength and everlasting qualities of the foundation determine the durability, safety and usefulness of the structure; so it is with a flexible, slate surfaced shingle.

A shingle cannot be better than its foundation. The felt base is its backbone. It depends for its useful life upon the resistance of its felt to fire, time and weather. Therefore, the most important thing



about a roofing of this kind is the nature of the raw materials used in the manufacture of the felt.

The base of the ordinary asphalt shingle is a rag felt which is partly rags and in some cases partly jute, waste paper and other refuse material. It will burn to a cinder.

The base of Johns-Manville Flexstone Shingles is the same asbestos rock fibre that is used in all Johns-Manville Asbestos Roofings. It is proof against rot, weather and fire.

That is why Flexstone Asbestos Shingles are superior. The natural durability—the practically indestructible nature of their asbestos felt base assures longer and more economical service and a greater degree of fire protection.

Flexstone Asbestos Shingles are better, more durable and more fire-safe because of what is **IN** them rather than because of what is **ON** them. And yet they cost little more than rag-felt shingles.

As for the surfacing: On Flexstone

Shingles the only function of the slate is to provide an attractive, colorful surface rather than a further protection for the felt. Asbestos felt needs no such protection. It is not dependent upon any kind of surfacing for its resistance to time, fire and weather.

Flexstone Asbestos Shingles are attractive in appearance; moderate in first cost, easy to apply, fire-safe and they will not curl when properly applied.

Flexstone Asbestos Shingles are furnished with a surfacing of crushed slate in soft Red, a cool Green and a rich Blue-black.

Johns-Manville Flexstone Shingles are approved by Underwriters' Laboratories, Inc. **ASBESTOS SHINGLES ARE THE ONLY FLEXIBLE COMPOSITION SHINGLES** that take base rates of insurance. Flexstone Asbestos Shingles have been labelled Class "B," the highest rating for this type of shingle. Many localities prohibit roofs of lower rating than Class "B."

## Made in Two Styles and Three Sizes

(1) Flexstone Rectangular Individual Shingles; size 8" x 12<sup>3</sup>/<sub>4</sub>"; 424 shingles will cover 100 square feet of surface. Shipped in bundles of 1/4 square of 106 shingles, including directions for application. Approximate shipping weight: 230 lbs. per square.

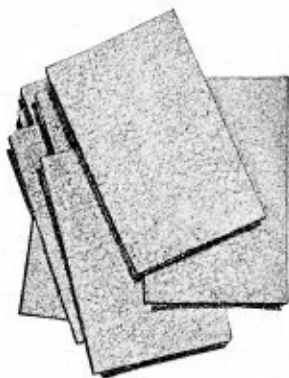

Flexstone Asbestos Individual Shingles. Size 8" x 12<sup>3</sup>/<sub>4</sub>".

6 lbs. of 1" large head galvanized nails per square required for application.

(2) Flexstone Strip Shingles. A strip of asbestos slate surfaced felt 32" long by

10" or 12<sup>3</sup>/<sub>4</sub>" wide, notched to represent four shingles. 112 strips will cover 100 square feet. Shipped in bundles of 1/2 square of 56 strips, including directions for application. Strip shingles are quicker and easier to lay and require fewer nails. Approximate shipping weight 10" width 185 lbs., 12<sup>3</sup>/<sub>4</sub>" width 240 lbs. per square.

4 lbs. of 1" large head galvanized nails per square required for application.



Flexstone Asbestos Strip Shingles Size 32" x 10" or 12<sup>3</sup>/<sub>4</sub>".



## Standard Specifications for Application of Johns-Manville Flexstone Rectangular Individual Asbestos Shingles

(Size 8" x 12 $\frac{3}{4}$ " )

### ROOF BOARDS

Lay the roof boards in the usual manner, breaking joints and nailing securely in place with at least two nails at each rafter, leaving no loose ends. The roof boards shall be well-seasoned, of narrow width and uniform thickness; tongued and grooved preferred.

### MATERIALS

Shingles shall be a heavy weight single thickness of asbestos felt impregnated with asphalt, the weather surface to be covered with crushed slate, same to be Johns-Manville Flexstone Rectangular Asbestos Shingles (red, green or blue-black), size 8" x 12 $\frac{3}{4}$ ", laid up in the following manner:

### ROOFING

At the eaves apply sheet metal drip edge (painted both sides), or a wooden strip, overhanging the eave approximately  $\frac{1}{2}$ ".

Line the valleys with sheet metal, or Johns-Manville Flexstone Slate Surfaced Asbestos Roofing. If the slate surfaced roofing is used it shall be applied in two layers, the first layer being 12" wide and the second or top layer, being 20" wide.

Lay the first, or starting course, of shingles vertically and butted together, flush with drip edge, thus making a solid strip along the eave, 12 $\frac{3}{4}$ " wide.

Lay another starting course directly on top of the first and flush with same, starting at the left with a one-third width shingle (2 $\frac{2}{3}$ " x 12 $\frac{3}{4}$ " ), so that all joints will be broken with first starting course. Space these shingles  $\frac{1}{2}$ " apart.

Start the first main body course at the end 4" up from the eave, with a whole shingle. Start the next course with a two-third width shingle (5 $\frac{1}{3}$ " x 12 $\frac{3}{4}$ " ). Start the third main body course with a whole shingle, and the fourth course with a one-third width shingle, and so on in rotation, breaking all joints one-third and two-thirds and spacing all main body shingles  $\frac{1}{2}$ " apart.

All shingles shall have a weather exposure of 4".

### NAILING

Each shingle shall be nailed to the sheathing with two large head galvanized nails at least 1" long. These nails shall be placed 5" above the butt and  $\frac{3}{4}$ " in from the sides.

### HIPS AND RIDGES

After the main body shingles have been applied, hips and ridges shall be covered with Johns-Manville Flexstone Slate Surfaced Asbestos Roofing or individual shingles.

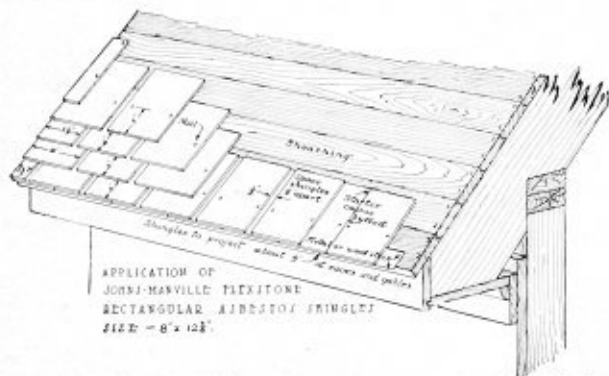

If the slate surfaced roofing is used it shall be cut into strips approximately 8" wide and applied extending 4" each side of hip or ridge. Both edges shall be securely nailed with large head galvanized nails at least 1" long. These nails shall be spaced approximately 2" center to center and placed  $\frac{3}{4}$ " from edge.

If the individual shingles are used application shall be started at either end of ridge and lower end of hip. Apply one shingle flush with main body shingles, extending 4" each side of hip or ridge. Apply another shingle in the same manner and directly over the first. Apply the next shingle in a similar manner, 4" from the butt of the first shingle, fastening each shingle with two large head galvanized nails at least 1" long. These nails shall be placed 5" from the butt and  $\frac{3}{4}$ " in from the sides, one either side of ridge or hip. Apply succeeding shingles in a similar manner, exposing 4" of each shingle to the weather.

### FLASHING

Flash and counter flash, where necessary, with sheet metal applied in an approved manner.

### SIDING

Except as hereinafter noted, the specification for applying roofing shall apply to Siding:

Allow  $\frac{1}{4}$ " space around all doors, windows, etc., to permit shingles to be carried behind face boards, (these face boards shall be put on after the shingles have been applied and shall lap the shingles at least 2".)

The shingles shall be exposed 3" to the weather, nailing each shingle with two large head galvanized nails at least 1" long. These nails shall be placed 4" above the butt and 1" in from the sides. Secure the two lower corners of the exposed butt of each shingle with small copper brads or small headed nails.





## Standard Specifications for the Application of Johns-Manville Flexstone Asbestos Strip Shingles

(Size 10" x 32" or 12 $\frac{3}{4}$ " x 32")

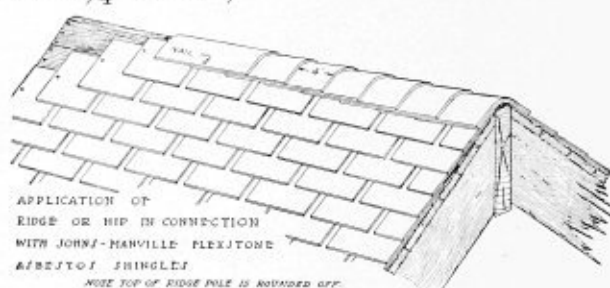
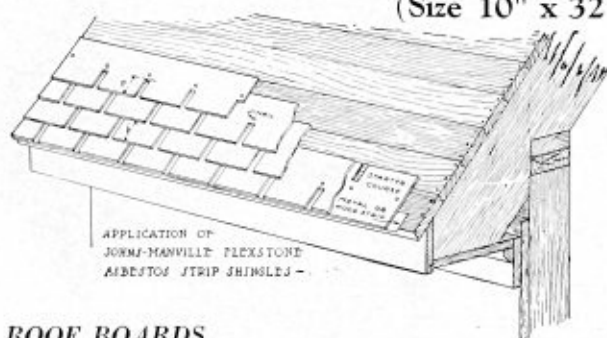

### ROOF BOARDS

Lay the roof boards in the usual manner, breaking joints and nailing securely in place with at least two nails at each rafter, leaving no loose ends. The roof boards shall be well-seasoned, of narrow width and uniform thickness; tongued and grooved preferred.

### MATERIALS

Shingles shall be a heavy weight single thickness of asbestos felt impregnated with asphalt, the weather surface to be covered with crushed slate, same to be Johns-Manville Flexstone Asbestos Strip Shingles (red, green or blue-black), size 10" x 32" or 12 $\frac{3}{4}$ " x 32", laid up in the following manner:

### ROOFING

At the eaves apply sheet metal drip edge (painted both sides), or a wooden strip, overhanging the eave approximately  $\frac{1}{2}$ ".

Line the valleys with sheet metal, or Johns-Manville Flexstone Slate Surfaced Asbestos Roofing. If slate surfaced roofing is used, it shall be applied in two layers, the first layer being 12" wide and the second, or top layer, being 20" wide.

Lay the first, or starting course, of shingles flush with the drip edge with the cutouts up the roof, butting the strips end to end.

Lay another starting course directly on top of the first and flush with same, with the cutouts down the roof, breaking joints. Butt the strips end to end.

Start the first main body course at the end 4" up from the eave, with a strip from which half of the end shingle has been cut longitudinally. Start the next course above with a full width strip, and so on in rotation to break joints.

All shingles shall have a weather exposure of 4".

### NAILING

Strips shall be nailed to the sheathing with one large head galvanized nail at least 1" long above

each cut-out, and one at the end of each strip. These nails shall be placed 5" up from the butt and  $\frac{3}{4}$ " in from the sides. Center nails shall be driven first.

### HIPS AND RIDGES

After the main body shingles have been applied, hips and ridges shall be covered with Johns-Manville Flexstone Slate Surfaced Asbestos Roofing or individual shingles.

If the slate surfaced roofing is used, it shall be cut into strips approximately 8" wide and applied extending 4" each side of hip or ridge. Both edges shall be securely nailed with large head galvanized nails at least 1" long. These nails shall be spaced approximately 2" center to center and placed  $\frac{3}{4}$ " from edge.

If the individual shingles are used same shall be cut from the strip shingles and application shall be started at either end of ridge and lower end of hip. Apply one shingle flush with main body shingles, extending 4" each side of hip or ridge. Apply another shingle in the same manner and directly over the first. Apply the next shingle in a similar manner 4" from the butt of the first shingle and fasten with two large head galvanized nails at least 1" long. These nails shall be placed 5" above the butt and  $\frac{3}{4}$ " in from the sides, one either side of ridge or hip. Apply succeeding shingles in a similar manner, exposing 4" of each shingle to the weather.

### FLASHING

Flash and counter flash, where necessary, with sheet metal applied in an approved manner.

*Siding*—Note: Refer to same paragraph in specification for Flexstone Individual Shingle on page 163 and follow same instructions. In writing this specification, copy as part of it the "Siding" paragraph, making the following change: "These nails shall be placed 4" above the butt and 1" from the cutout."





Edgewater Saw Mills, Tompkinsville, N. Y., covered with Johns-Manville Rag-Felt Roofing.

## Johns-Manville Rag-Felt Shingles and Ready-to-Lay Roofings

**W**HILE our Asbestos Ready-to-lay Roofings are the most satisfactory and economical in the long run, sometimes the matter of first cost, or nature of the building, confines the choice to the rag-felt type of roofing.

To meet this demand Johns-Manville makes rag-felt roofings, and makes them according to the same high standards of manufacture that govern the production of all its roofings. This assures the best return on the money invested no matter what type you buy.

Johns-Manville Rag-felt Roofings are made of carefully selected, clean rag-stock free from straw, jute and similar shoddy. This rag-stock is fabricated into tough felts that are thoroughly saturated, literally soaked with a combination of waterproofing, life-giving, natural asphalts, sealed into the felt by a heavy coating of

the same natural asphalts on both sides.

The life of rag-felt roofing is largely dependent upon the character of the waterproofing used, so we choose only those that best resist the action of the sun and wear and tear of weather.

In the selection of our asphalts we have no particular one to exploit. We compound and process asphalt materials in the light of most recent, up-to-date knowledge, without regard to what anyone else is doing or exploiting. We own no oil wells; we own no asphalt deposits; we are free to buy and use what experience teaches us is best. Therefore, the choice of the asphalts for roofing is made with the primary object of giving to the felt the maximum protection against time, weather and water, and to assure longest service with the minimum upkeep expense.



## Where Used—How Furnished



**J**OHNS-MANVILLE Rag-Felt Ready Roofings are for use on roof decks where the pitch is  $1\frac{1}{2}$ " or more to the foot.

Made 32" wide and shipped in one-square rolls (108 sq. ft.) or two-square rolls (216 sq. ft.), except Slatekote Brand, which is shipped only in one-square rolls. Pyramid Kaps or nails and cement, (as ordered), as well as directions for application are packed in each roll.

### Pilot Brand

The best grade of rag-felt roofing, which will give splendid service. Extensively used for barns, sheds, outhouses, garages, etc. Made in three weights: light, medium and heavy. Approximate shipping weight per square: light, 35 lbs.; medium, 45 lbs.; heavy, 55 lbs.



### Slatekote Brand

For use where an ornamental surfaced, inexpensive rag-felt roofing is desired. Made of a heavy sheet of rag-felt armored with a coating of crushed RED, GREEN or BLUE BLACK slate, which is securely

imbedded in asphalt on the surface of the felt. Has a 2" selvaged edge to permit the proper joining of laps. Made in one weight only; shipping weight, about 85 lbs. per square.

## Johns-Manville Slatekote (Rag-Felt) Shingles

Slatekote Shingles are made of the same high grade rag felt and under the same standards as Johns - Manville Rag-Felt Roofings described on page 165.

The base of Slatekote Shingles is a tough piece of rag felt heavily saturated and coated with natural asphalt and surfaced with crushed red, green or blue-black slate.

They afford better and longer service than the ordinary rag-felt shingle because of the greater care in the choice of the rag

stock, and the generous amount of asphalt saturation and coating used, and yet they cost about the same as the others.

Furnished in two styles—Individual Shingles and Strip Shingles. Individual Shingles 8" x  $12\frac{3}{4}$ "; shipped in bundles of  $\frac{1}{4}$  square; weight approximately 230 lbs. per square. Strip Shingles furnished in two sizes, 10" x 32" and  $12\frac{3}{4}$ " x 32". Both sizes shipped in bundles of  $\frac{1}{2}$  square; weight approx. 190 lbs. per square for 10" width, and 240 lbs. for the  $12\frac{3}{4}$ " width.



## Johns-Manville Asbestos Fibrous Enamel



An asphalt-asbestos fibre liquid coating for use on all metal and composition roofings. It is made in two colors, red and black, and in two consistencies—known as Ground and Unground Fibrous Enamel.

Ground Fibrous Enamel indicates that the incorporated asbestos fibre is ground to considerable fineness, and when applied to a roof produces a film that is smooth and paint-like in finish.

Unground Fibrous Enamel indicates that the incorporated asbestos fibre is of such length as to carry more of the asphalt content with it, thereby producing a heavy body to the finished product, which, when applied to a roof, produces a thick, "dauby" film.

The asphalts and oils used are the best obtainable, selected for their durability after years of extensive laboratory tests and field experience. The incorporated asbestos fibre has the same relation to our Fibrous Enamel as a pigment has to paint—it greatly retards the action of the actinic rays of the sun, the most destructive natural element to paints and coatings.

Johns-Manville Fibrous Enamel is the highest class product of its kind made. It is inexpensive and renders excellent service on any metal or composition roofing.

Ground and Unground Fibrous Enamel have a covering capacity of approximately 100 to 225 square feet per gallon, respectively, depending somewhat on the condition of the surface to be coated. Two coat work is always advisable.

## Johns-Manville Asbestos Slater's Felt

**A**N insulating felt made of asbestos fibres, impregnated with natural asphalts. Used as an insulating and waterproofing material between roof boards and shingles, slate, tile, etc.; also between siding and shingles and for similar building insulating purposes.

As it contains no vegetable, animal or organic material it is rot and weatherproof and will last indefinitely. Made 32" wide and shipped in 3-square rolls. Weight approximately 14 lbs. per square.



## Johns-Manville Asphalt Roofing Cement

For the application of built-up roofing or to re-waterproof and provide a weather-proof surface finish for old roofing felts; for the laying of patch strips or full sheets of felt in general roofing repair work, where conditions demand a mopping of hot asphalt.

Johns-Manville Asphalt Roofing Cement is shipped in full, one-half and one-quarter drums, weighing approximately 400, 200 and 100 lbs., respectively. As shipped it is a solid, hard mass which is melted in kettles at the job and applied hot.





## Johns-Manville Asbestos Roof Putty

A plastic cement used to stop leaks, due to holes in tin, zinc, slate, shingle, wood or composition roofs, gutters or flashings; also for pointing up around leaky chimneys, skylights, etc.; in fact, may be used for any job where leak-proof

repair cement is desired.

Shipped ready for application in black, red and gray in 1, 2, 3 and 5 lb. cans, 25, 50, 150, 300 and 500 lb. containers.



## Johns-Manville Iron Preservative

A high class asphaltic liquid coating made of materials selected for their known durability. This product is made under two formulas, known as Inside and Outside Iron Preservative.

Inside Iron Preservative is immune to the action of lime, and is therefore recommended for use on structural steel which may or may not be encased in cement or other mortar and where the sunlight is indirect.

Outside Iron Preservative is designed principally for outside work, as it possesses high resistance to the actinic rays of

the sun, acid and gas fumes. It is recommended for use on all exposed metal work such as steel bridges, corrugated iron siding, iron lamp posts, iron fences, water tanks, fire escapes, cranes, trolley poles, iron electric railway poles, farming implements, etc.

Both Inside and Outside Iron Preservative dry hard and with a reasonably bright finish. Neither will peel or crack if used over a dry, well-cleaned surface. Two coat work is always advisable, preferably a shop coat of red lead and a field coat of Iron Preservative or two coats of Iron Preservative in the field.

## Johns-Manville Cold Water Paint

*(For Interior Use)*

Johns-Manville White Cold Water Paint makes a durable, fire-resisting coat-



After an application of Johns-Manville Cold Water Paint.

ing for all interior building and other surfaces; brick, stone, concrete, plaster or wood. For the interior of train sheds, factories, warehouses, garages, docks, freight houses, interior squash, tennis and handball courts, gymnasiums, hotels, clubs, hospitals, office buildings, stables, etc.

Furnished in white and sixteen tints, which can be intermixed to obtain any other desired tint, or can be deepened in tone by adding a small portion of ordinary tinting colors.



# Johns-Manville Transite Asbestos Wood

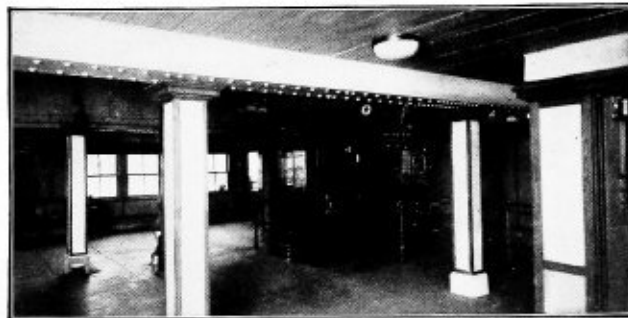



Johns - Manville (Flat) Transite Asbestos Wood provides durability, economy and fire protection inside or outside of buildings as shown by these views of a Boston and Westchester Railroad Station in New York.



## Johns-Manville Transite Asbestos Wood

**J**OHNS-MANVILLE Transite Asbestos Wood is a (flat) rigid, all-mineral material for general use in permanent, fireproof interior and exterior construction, in place of natural wood, plaster, wall-board, stucco or sheet metal.

Johns-Manville Transite Asbestos Wood is made of asbestos fibres and Portland cement united under hydraulic pressure into dense, homogeneous, structurally strong sheets of various sizes and thicknesses.

Johns-Manville Transite Asbestos Wood has all the desirable properties of natural wood and sheet metal but it is superior to them. Unlike natural wood Transite is not inflammable. It cannot burn because it is actually a sheet of stone—neither will it rust, dent or buckle like sheet metal. And Transite never needs paint or any other surface protection which eliminates the expense and bother of maintenance so necessary for natural wood and sheet metal.

### Easy to Apply

Johns-Manville Transite is easy to apply. It is comparatively light in weight and can be handled in the same manner and with practically the same ease as any hard wood. It can be cut and worked with ordinary tools and fastened with nails, screws or bolts.

It is unaffected by water, alkali and most acids. Sudden or extreme changes

of temperature do not affect it in any way; it actually becomes tougher with age.

It has many of the physical characteristics of ordinary wood, except that it is harder and takes a higher polish.

It has a fibre strength under transverse loads of 3,500 pounds per sq. in., being about two-thirds as strong as ordinary wood.



## Attractive Appearance

Transite has a neat, attractive appearance. Its smooth, gray surface permits its use just as it comes from the factory but where it is necessary to have Transite match the surroundings it can be painted, varnished or grained as desired.

In every way Transite Asbestos Wood is the ideal material for walls, partitions, panelings, ceilings, fire doors, roofing or siding, because it provides the maximum of fire protection and durability with the

minimum of construction thickness.

Johns-Manville Transite Asbestos Wood is approved by Underwriters' Laboratories, Inc.

Its fireproof nature, its durability, its service economy and many other desirable qualities recommend it strongly to architects and engineers for use in railway stations, public buildings, restaurants, shops, garages, factories and for many of the purposes suggested in the list below.

## How Furnished

Transite Asbestos Wood is made in two finishes — STANDARD and SPECIAL. Standard Transite is *reasonably* smooth on both sides. Special Transite is *perfectly* smooth on both sides and is preferable for use where precise and uniform thickness throughout is desired. Both kinds are furnished in sheets 36" x 48", 42" x 48" and 42" x 96" in the thicknesses shown below. The finish of the 1/8" thickness is slightly

different—it is reasonably smooth on one side and slightly pebbled on the other. It is only furnished in the 42" x 96" sheet when specially ordered.

Where it may be desired to use a flat instead of a corrugated material, Special Lipped Transite is recommended. Details of application of this material will be found on page 173.

Thickness: . . . . .	1/8"	3/16"	1/4"	5/16"	3/8"	1/2"	3/4"	1"	1 1/4"	1 1/2"	1 3/4"	2"
Approximate Weight per Sq. ft. lbs.,	1.7	2.1	2.8	3.4	4.0	5.3	7.6	10.1	13.0	15.7	18.5	21.0

## A Partial List of Uses in Prominent Industries

### Automobile Manufacturers

Acid fume ducts and openings  
Automobile foot boards  
Baffles  
Ceilings, walls, partitions, sidings; walking surface over enameling ovens; over railroad switching tracks in warehouses  
Dry kilns  
Furnace dampers and doors  
Smoke flues and breeching lining  
Ventilators

### Chemical Industry

Acid fume ducts and openings  
Bus-bar barriers and spacers  
Ceilings, walls and partitions  
Cabinets, boxes and similar equipment in laboratories, etc.  
Fume Hoods  
General Fireproofing  
Furnace dampers and doors  
Smoke flues and breeching lining

Table, sink tops and hoods  
Ventilators

### Manufacturing General

Drying and enameling ovens  
Baffles—Over oil stills; in storage battery dry plate kilns; between Burton stills  
Ceilings, walls and partitions  
Canopies over loading platforms  
Cabinets; boxes and similar equipment  
Dry Kiln Partitions  
Fire doors  
General Fireproofing  
Fireproof Partitions—Office and Industrial buildings  
Furnace dampers and doors  
Fireproofing Elevator shafts  
Powder Houses  
Smoke flues and breeching lining  
Storage Bins  
Siding and roofing  
Oil and Gasoline Storage Rooms  
Ventilators

### Oil Refineries

Ceilings, walls and partitions  
Curtain walls between condensers in refineries  
Cabinets, boxes and similar equipment  
Dampers  
General Fireproofing  
Furnace and Flue dampers and doors  
Fire Barriers  
Housing for Insulated Pipe Lines  
Ventilators

### Railroads

Ceilings, walls and partitions  
Canopies over stations and loading platforms  
General Fireproofing  
Under upholstering of car seats where heating coils are installed  
Portable houses

Smoke jacks  
Ventilators  
Smoke Ducts

### Rubber and Rubber Goods Manufacturers

Ceilings, walls, partitions  
Curing rooms  
General Fireproofing  
Furnace dampers and doors  
Laboratory Table tops  
Ventilators

### Textile Industry

Acid fume ducts and openings  
Bins for storage of hemp, sawdust or textiles  
Ceilings, walls and partitions  
Fire doors  
General Fireproofing  
Smoke flues and breeching lining  
Table tops  
Ventilators



## Johns-Manville Service to Industry



Transite Asbestos Wood gives interior walls and ceilings the utmost in attractiveness. This is the station dining room, Erie R. R., Jersey City, N. J.

Office partitions of Transite are of rock as durable as the building's foundation. Also attractive, light in weight and easily decorated.

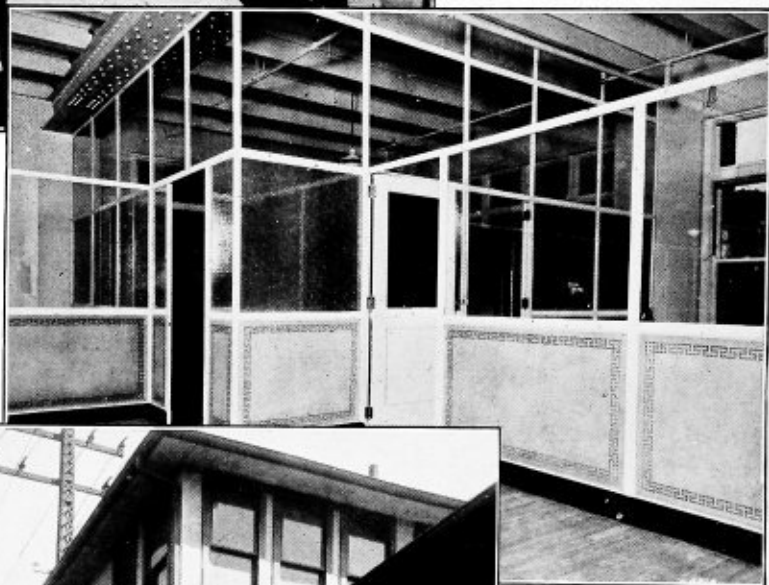

This station of the Boston and Westchester R. R. (New York) is permanently protected by its siding of fire-proof and weather-proof Transite Asbestos Wood.









## Johns-Manville Transite Asbestos Wood Stacks and Caps

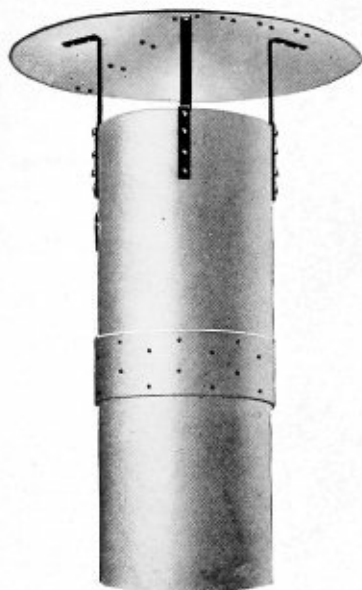

## Johns-Manville Transite Asbestos Wood Ventilators

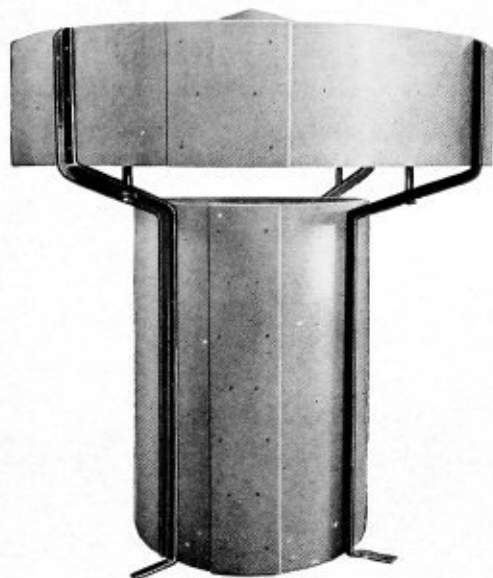

Painting and similar forms of maintenance are unnecessary with these two products. Being made of Transite Asbestos Wood their all-mineral composition defies weather and acid fumes. They never need painting and actually grow tougher with age which is the exact reverse of experience with wood or iron products.

**J**OHNS-MANVILLE Transite Asbestos Wood Stacks and Caps are made in all sizes and for all purposes. The materials used in the construction of these stacks is Transite Asbestos Wood described in detail on page 170.

They are used principally over forges in machine shops, on gas houses and chemical laboratories, or as flues for conducting acid and alkaline gases, as they are quite impervious to such destructive agencies.

We are in a position to quote on Johns-Manville Transite material made to any special shape for stacks, flues, hoods or ducts.

Prices upon application.

**J**OHNS-MANVILLE Transite Asbestos Wood Ventilators are adaptable wherever the common wood, iron and copper ventilators are installed. They are especially recommended for engine houses, gas and power houses, laboratories, factories, etc., where it is essential to select a material that will withstand the action of acid and alkaline fumes and gases.

These ventilators are constructed of Johns-Manville Transite Asbestos Wood as described on page 170, that is, a composition of Asbestos Fibre and Portland Cement—recognized as the most durable and time-resisting materials used in engineering. Prices upon application.

See next page for dimensions, etc.



# Johns-Manville Transite Asbestos Wood Ventilators

(Continued)

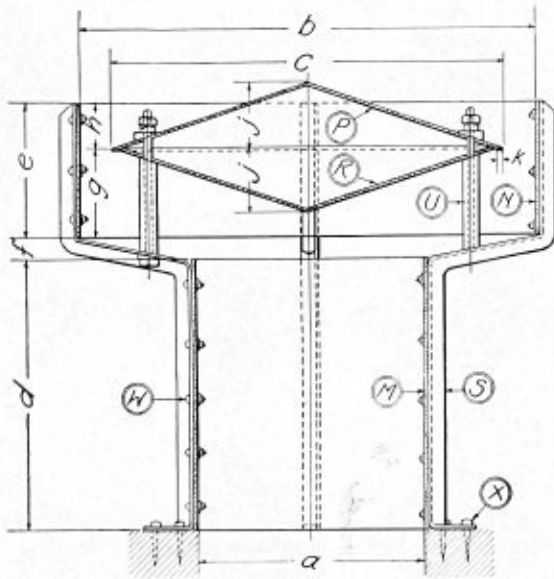

Type "D."

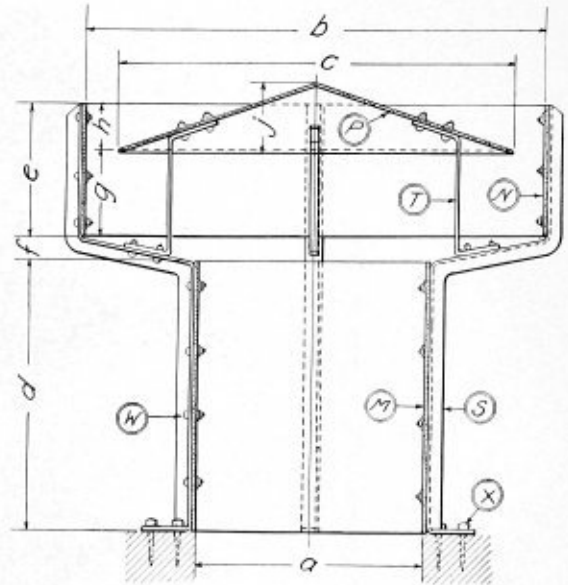

Type "E."

## DESCRIPTION

The following tabulation describes those parts of the ventilators illustrated above which are marked with similar letter references:

- M.....Johns-Manville Transite Asbestos Wood Stack
- N.....Johns-Manville Transite Asbestos Wood Guard
- P.....Johns-Manville Transite Asbestos Wood Upper Cone
- R.....Johns-Manville Transite Asbestos Wood Lower Cone
- S.....Angle Iron Ventilator Support
- T.....Bar Iron Cap Support
- U.....Bolt and Separator Cap Support
- W.....Round Head Stove Bolt
- X.....Lag Screw

## TABLE OF DIMENSIONS IN INCHES

Type "D" No.	Type "E" No.	a	b	c	d	e	f	g	h	j	k
1	11	10	20	17	14	7	1	5½	2½	3	1½
2	12	18	36	31	21	10½	1½	7	3½	5	1½
3	13	24	49	42	30	14	2	9	5	6	1½
4	14	30*	61	54	42	14	5	9	5	8	1½
5	15	36	74	64	48	21	3	14	7	10	1½

\* Outside diameter of stack.



# Johns-Manville Housline

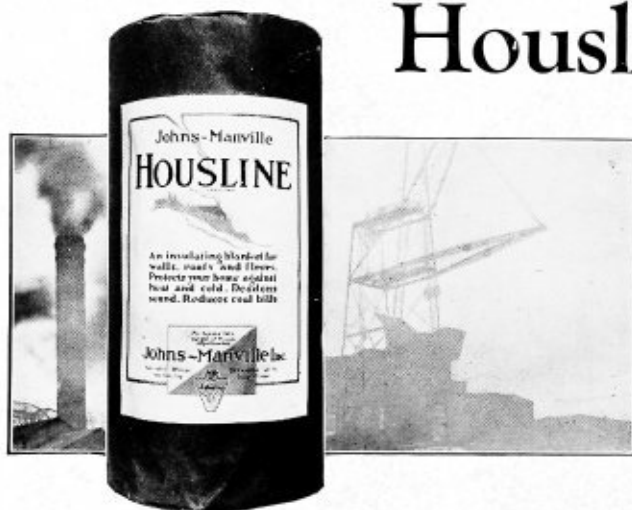

Widely Known for Many Years  
as Keystone Hair Insulator



## Johns-Manville Housline

**H**OUSLINE is a building insulation that meets adequately the three requirements for such a material:

- It saves coal.
- It makes buildings more comfortable summer and winter.
- It retards the passage of sound through walls, partitions and floors.

Housline is used in new buildings or old, wherever it is desirable to prevent the passage of heat, cold, moisture or sound—offices, factories, warehouses, dormitories, dwellings, mills, etc.

The saving in coal by the use of Housline for the insulation of outside surfaces quickly pays for the material and the cost of its application. The even temperature of buildings insulated

with Housline makes your workers more comfortable and healthful—a sure way to increase output and reduce waste.

Progressive architects and owners specify building insulation because they know the value of heat conservation and comfortable buildings for their personnel.

Johns-Manville Housline meets their requirements because it is the best and most economical insulation made.

If it is your desire to reduce coal bills each year and have buildings that are more comfortable and quieter the year around, you will specify Johns-Manville Housline.

Illustration shows construction of Johns-Manville Housline.

Waterproof felt.  
Building paper.

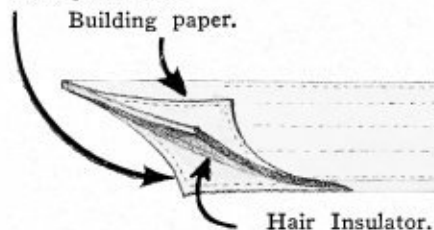

Hair Insulator.

## Building Insulation

*An Investment in Comfort and Economy*

Efficient wall, floor, ceiling and roof insulation is an investment—not an expenditure. It pays dividends every year it is in service in the added comfort and greater operating economy it affords.

But what is proper and efficient insulation? How can owner, engineer or archi-

tect differentiate between the good and bad in the various kinds of insulation that are offered? Clearly, the best insulation must answer certain definite requirements and because Housline measures up squarely to the conditions for which it is recommended we offer it as the best insulation and stand ready to prove our claims.



## A Few Reasons Why Johns-Manville Housline Is Superior

**T**O meet the exacting demands of modern construction practice a building insulation must be sanitary, fire-resisting and durable or it is a menace to health, to safety and to your investment.

It must be durable because deterioration and the necessity for replacement in a few years not only mean annoyance and expense but such work is practically impossible after the building has been completed and occupied. And it certainly should not carry flame.

And what is more important—it must be vastly more than a mere “filling.” It must insulate effectively by offering the maximum resistance to heat, cold, dampness and sound.

How many insulations meet such rigid requirements? Investigation shows that the majority of the average “insulations” can be quickly rejected. They are un-

clean, furnish refuge for vermin, are highly inflammable, rot, “pack down” or have little or no insulating value because they are too tightly packed or are not adaptable as good insulation.

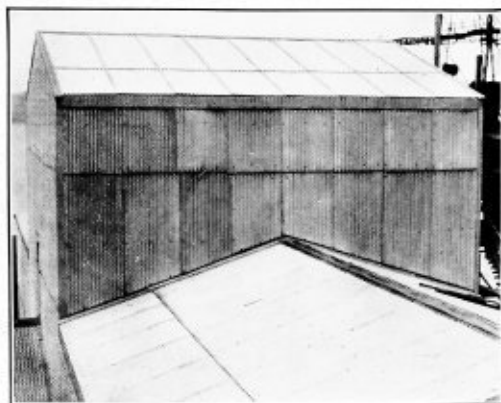

This building at the Edgewater Plant of The Warner Sugar Refining Company is insulated against heat and cold by Johns-Manville Housline.

Johns - Manville Housline, because of its construction and the materials of which it is made, has none of these drawbacks.

The insulating material used in Housline is Nature's own protection—chemically cleansed cattle hair, securely stitched between a sheet of waterproof felt and a sheet of building paper. You are thereby afforded

the most efficient building insulation.

Housline wont “pack down;” it wont carry flame; it is thoroughly cleansed and vermin proof and will not rot. Once applied it gives permanent insulation without maintenance cost.

## Actual Savings in Coal by the Use of Johns-Manville Housline

The illustrations on page 183 show typical methods of outside wall construction with Johns-Manville Housline installed as a heat and cold insulation, in comparison with the same forms of construction without insulation.

No. 1 shows wall without insulation.

Nos. 2 and 3 show application of one layer of Johns-Manville Housline. No. 4 shows the application of two layers of Housline.

As an example of the efficiency of Housline, the rate of heat transmission through No. 2 is only .182 B.t.u. per square



foot of exposed wall surface per hour, per degree temperature difference between air inside the building and air outside, while the loss through the same construction (No. 1), without Johns-Manville Housline, is .28 B.t.u. under the same conditions.

Translating these figures into pounds of coal saved by the use of Housline in outside walls, shows an actual saving of 236 pounds of coal for every 100 sq. feet of exposed sidewalls during a heating season of 210 days, with an average temperature difference of 40° F.

The rate of heat transmission through No. 4 is only .135 B.t.u. per sq. foot per deg. temp. difference per hour, as compared with the loss of .28 B.t.u. through



The walls and floors of this structure built by the Horton Building Co. are sound deadened with Johns-Manville Housline. Schwartz & Gross, Architects.

No. 1 under the same conditions. Therefore, there is less than half of the heat loss through a wall insulated with two layers of Johns-Manville Housline as shown in No. 4 than through an uninsulated wall, as shown in No. 1.

With No. 4 the actual saving in coal is 348 pounds for every 100 sq. feet of exposed sidewalls during a heating season of 210 days, with an average temperature difference of 40° F.

The net results to the user of Johns-Manville Housline are such a saving in coal consumption as should pay for the material in a short time; maintenance of more even temperature in his building; cooler in summer, warmer in winter and more comfortable and quiet at all times.

## Description of Housline

**J**OHNS - MANVILLE HOUSLINE consists of a heavy layer of thoroughly cleansed cattle hair securely fastened between two protective sheets. One side is plain building paper; the other side heavy waterproofed felt.

The body of Housline is the best grade of cattle hair, treated chemically to render it vermin-proof and odorless. It will not dry out, split, pack down or rot with age and lasts indefinitely. As it merely shrivels when it comes in contact with fire, it will not carry flame.

Housline is light in weight and therefore easy to handle. It is uniform in thickness throughout and being flexible, fits odd corners, making it easy to apply.

Furnished in rolls 3 ft. wide containing 250 square feet with the edges bound and beveled. It spreads on surfaces as easily as paper or wool felt and is, therefore, easily applied. The bound and beveled edges allow a 2" lap instead of having to be butted, thus assuring tighter and more effective application.





### Where Used for Insulation or Sound Deadening

**J**OHNS - MANVILLE HOUSLINE is recommended for the following uses; but this is by no means a comprehensive list, as Housline serves in almost every place where an efficient, durable material is desired for heat and cold insulation and sound deadening.

*Sound Deadening:* Factories, mills, offices, residences, Y.M.C.A.'s, apartment

buildings, schools, hospitals, studios, hotels, dance halls, theatres, lodge rooms, dormitories, bowling alleys, etc.

*Insulation:* Factories, offices, mills, residences, garages, etc., refrigerator cars, ice boxes, cold storage and refrigerating plants.

Detail drawings on page 184 show some typical methods of insulation.

### Special Housline for Special Purposes

Housline for general use is protected on one side with building paper and the other with tough waterproof felt. For special conditions Housline can be furnished with plain or waterproof asbestos felt or wool felt. Get in touch with the

nearest Johns-Manville Branch, which will gladly make recommendations.

Housline Tape; for caulking windows and other special uses. Saves time and labor. Keeps out wind, moisture and dust. Furnished 2" wide in rolls 50' long.

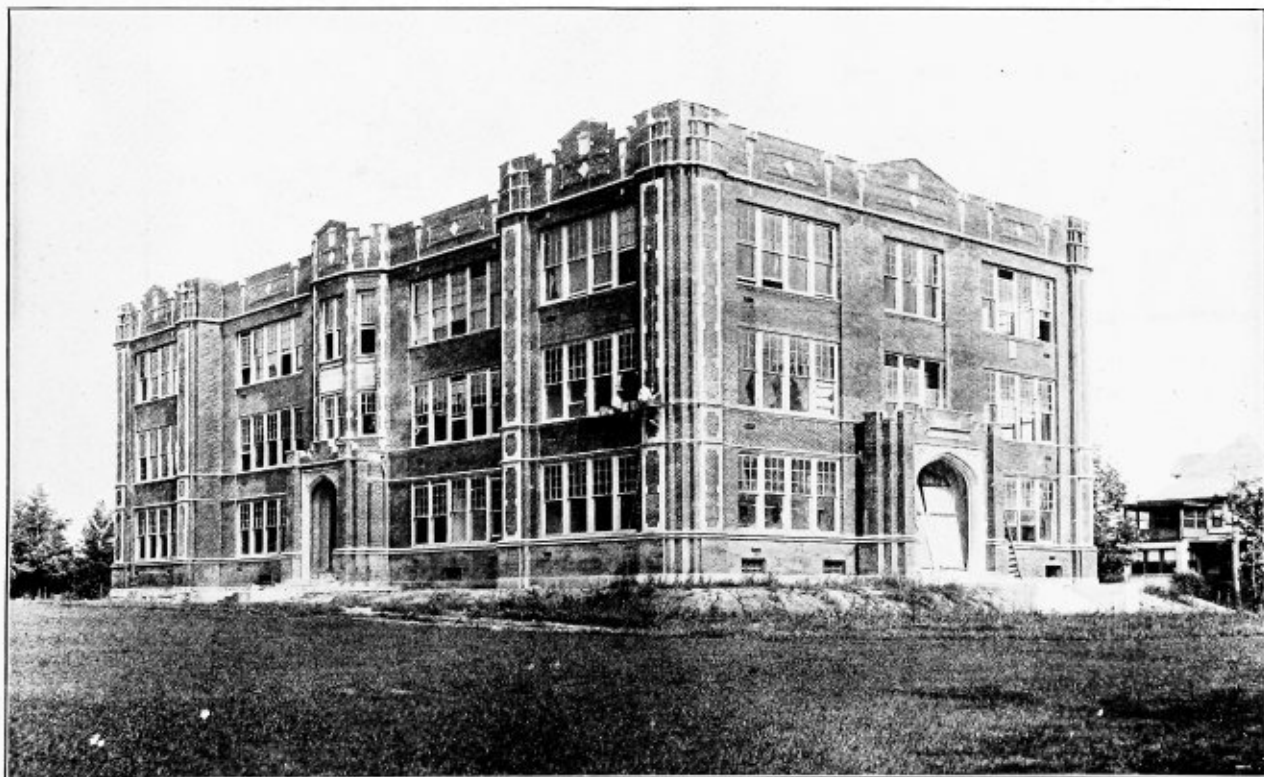

Science Hall, a new building for Marshall College, Huntington, West Va., insulated with Johns-Manville Housline. Housline saves coal and makes every building warmer in winter, cooler in summer and quieter all the time.



This Building of the Warner Sugar Refining Co.  
shows Housline in Ideal Construction

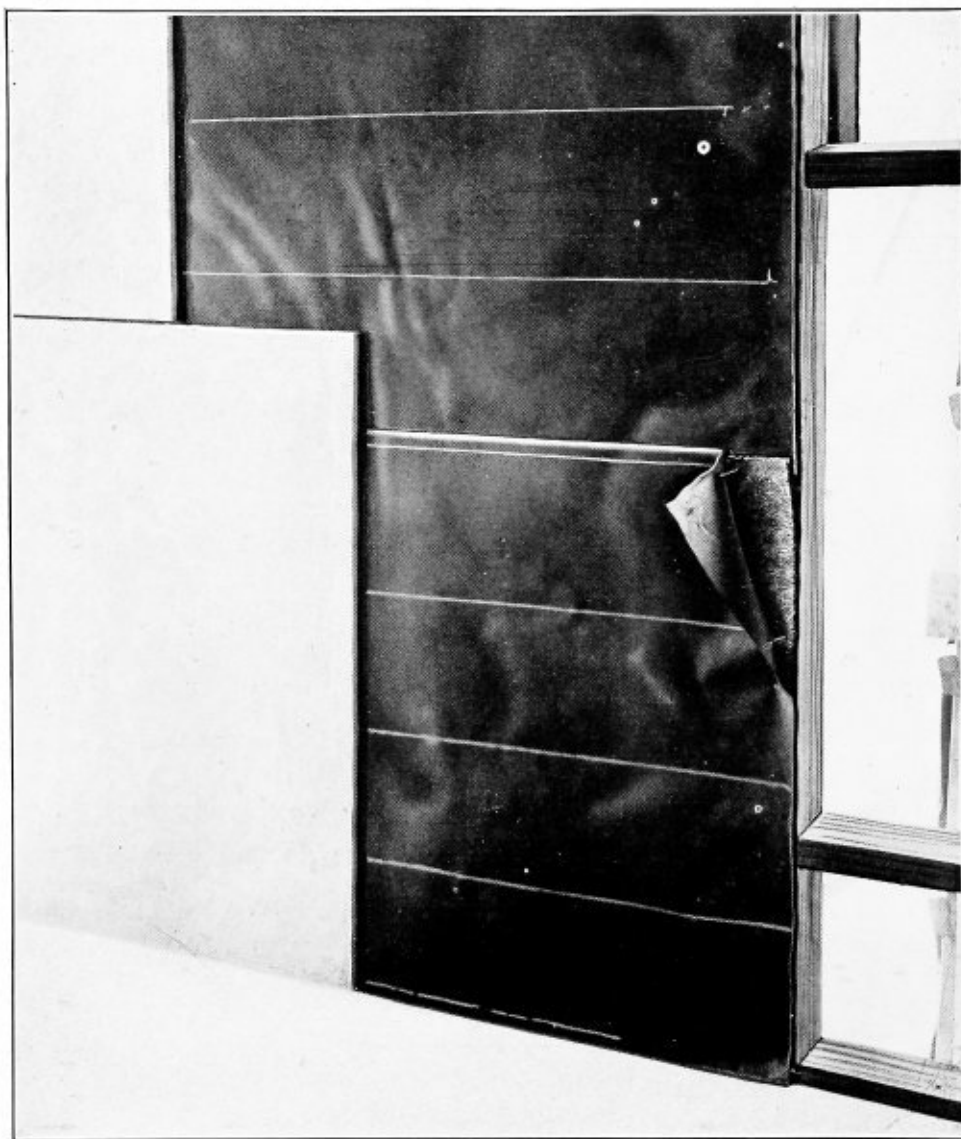

The above photograph shows Housline installed between the walls of one of the buildings at the Edgewater Plant of the Warner Sugar Refining Company. This is the ideal construction where the conservation of heat is essential in skeleton frame buildings.



## Diagrammatic Drawings of Typical Wall Constructions for Johns-Manville Housline

### VERTICAL SECTIONS

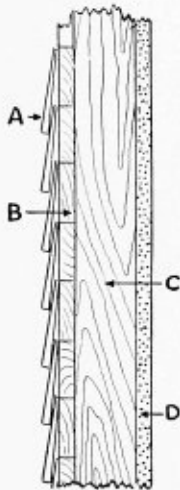

Construction No. 1

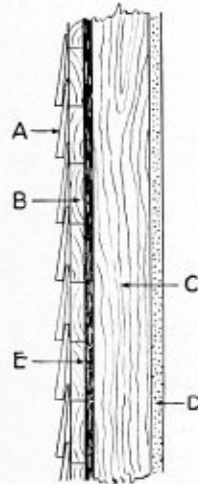

Construction No. 2

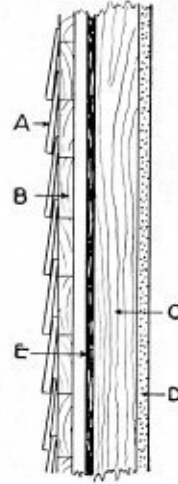

Construction No. 3

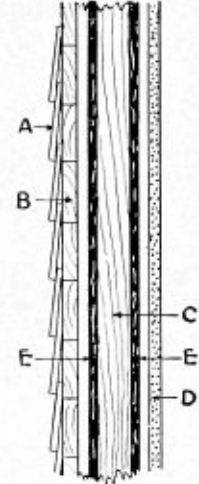

Construction No. 4

### KEY TO ALPHABETICAL REFERENCES IN DIAGRAMS

explained in detail in example on pages 179 and 180

A—Clapboards

B—Sheathing

C—Studding

D—Lath and Plaster

E—Johns-Manville Housline

### HORIZONTAL SECTIONS

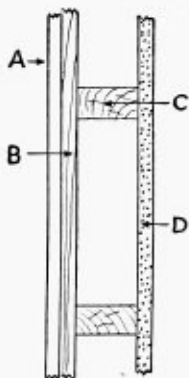

Construction No. 1

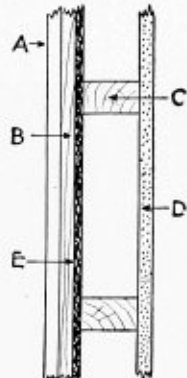

Construction No. 2

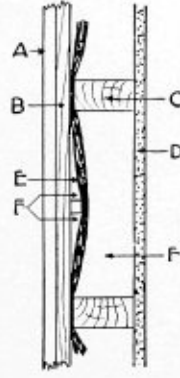

Construction No. 3

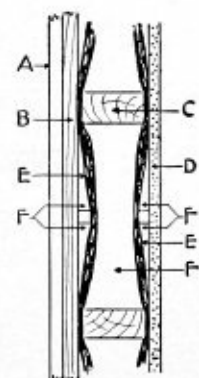

Construction No. 4

### KEY TO ALPHABETICAL REFERENCES IN DIAGRAMS

explained in detail in example on pages 179 and 180

A—Clapboards

B—Sheathing

C—Studding

D—Lath and Plaster

E—Johns-Manville Housline

F—Air Space

## Details of Application of Johns-Manville Housline

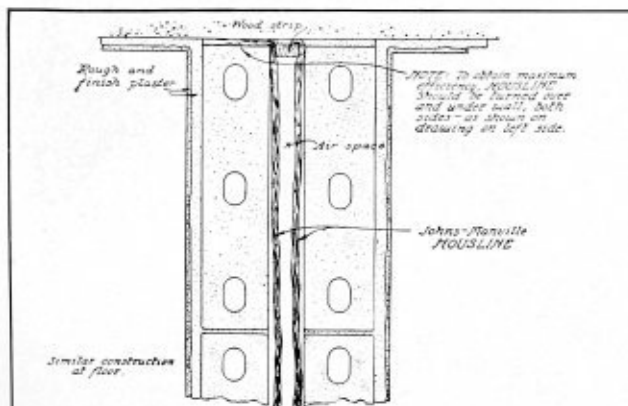

Section through partition, Gypsum Blocks or Hollow Tile.

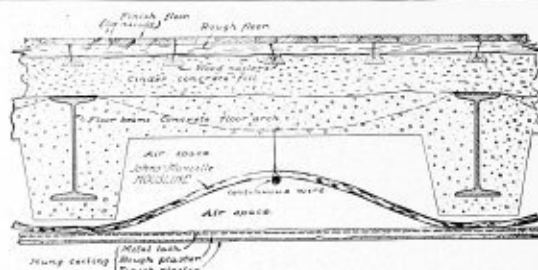

Housline in suspended ceiling.

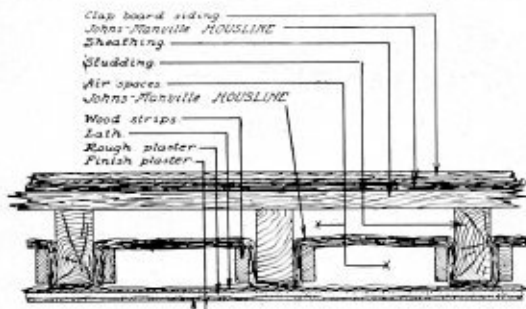

Plan of exterior wall frame construction.

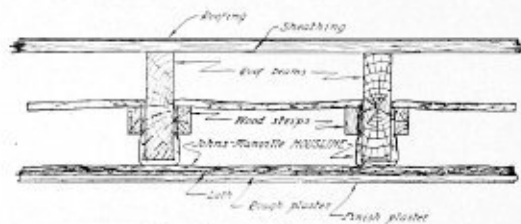

Housline under roof.

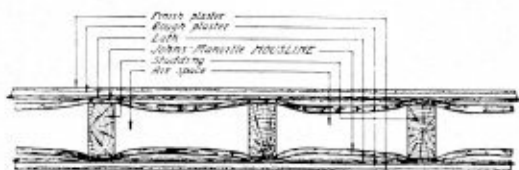

Plan of interior partition.

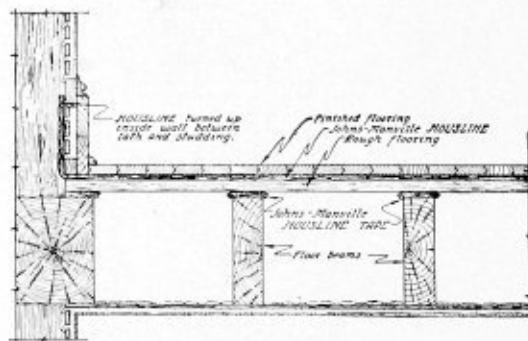

Housline between rough and finished floors.  
Housline tape on floor beams.

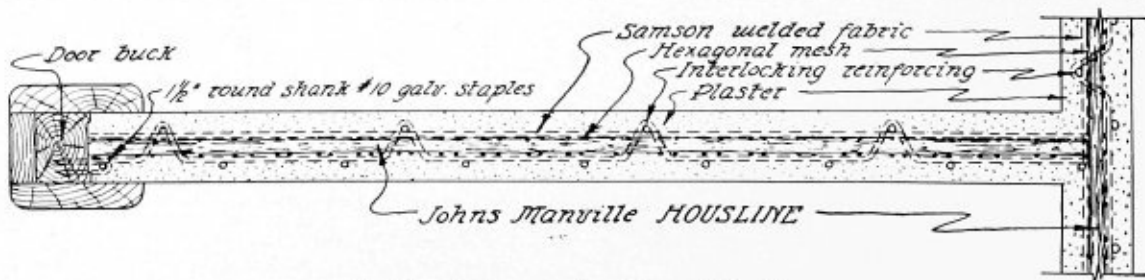

Housline in Samson Sound-proof Partition.



# Johns-Manville Industrial Flooring





# Johns-Manville Industrial Flooring

**A** FLOORING that is a solid monolithic sheet of mineral without construction joints or cracks; that can be laid in just the right consistency and thickness to meet the service conditions under which it is to be used.

A flooring that is resilient; slip-proof; easy under foot; dry and warm; fire retardant; alkali and acid resistant.

These are the features that make Johns-Manville Industrial Flooring supreme in its field—that free it from the shortcomings of other flooring which cannot be changed to accommodate the varying demands of different services. Johns-Manville Industrial Flooring is a combination of the best materials and the long experience of our engineers.

Its remarkable success is due:

1. To the natural durability of the materials of which it is made.
2. To its "flexibility" which permits fitting it exactly to service requirements, and—
3. To the fact that we control every element in its manufacture and application and can maintain a uniformly high standard.

There is no hit or miss about Johns-Manville Industrial Flooring. Our engineers carefully study your present or prospective service conditions — whether the grinding wear of heavy

trucks, the hard knocks of massive castings or the comparatively light weight of foot traffic—and recommend a proper consistency and thickness of Johns-Manville Industrial Flooring that will assure the greatest satisfaction. We know before any of the material leaves our factory what the floor must do and the recommendation of our engineer is rigidly followed by expert workmen whose skill is the result of constant application of our flooring in every part of the United States and Canada. So, the flooring, from the first measurement to the final finishing stroke on the top coat, is in the hands of conscientious experts—every precaution is taken and the responsibility for your satisfaction is concentrated in the Johns-Manville organization.

Johns - Manville Industrial Flooring consists of a binder or asphalt cement made up of a combination of natural asphalts and a well graded mineral aggregate ranging in size from that passing a  $\frac{3}{4}$ " screen down to that which passes a 200 mesh screen.

The finer aggregate, or that passing an 80 mesh screen, is combined with the asphalt cement by heating and mechanical agitation at our factory for a period of several hours. The mass is then molded into blocks of con-

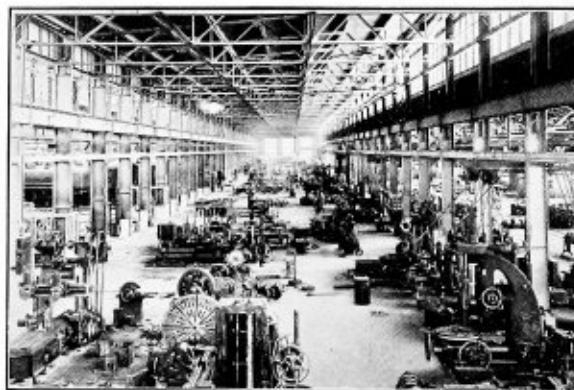

The extremely severe service conditions of the Canadian Pacific Railway Shop has proven the superiority of Johns-Manville Industrial Flooring.



venient size for shipment. These blocks are broken up on the work and reheated to a temperature of 450° F., mixed with the coarser aggregate, using a pure asphaltic flux to help break down the blocks in the kettle, giving proper consistency in the floor.

The resilient, softened and plastic mass is transported to the work in oak buckets, laid down hot in one and two courses, depending upon the required thickness and then given a comparatively smooth finish by rubbing with wood floats.

## Where Used— How Laid

Johns-Manville Industrial Flooring can be used for practically every condition in canning factories, railroad and machine shops, passenger and freight stations, loading platforms and docks, warehouses, freight houses, factories, roundhouses, cold storage plants, battery houses, chemical laboratories, Y. M. C. A. buildings, creameries, packing houses, office buildings, school buildings and institutions of every kind.

It can be laid over any foundation which is firm and stable such as wood, brick, concrete or tile already in place, in any desired thickness up to 3". The usual standard thickness is 1½" which affords maximum service at a commensurate cost. Can be laid in sections of any size and its installation does not necessarily occasion any delay in the routine of operation of a plant.

It adds very little to the dead load of the building as the standard thickness

of 1½" weighs only 18 lbs. to the square foot in place.

## Easy and Economical to Repair

This flooring is not only easily laid but easily repaired if changes in the floor surface are made necessary at any time or where unusual hard service or accident requires an occasional patch. In fact it is the only monolithic flooring which is so easy to repair. Just cut out the damaged section, reheat the very material that has been taken out, together with a small amount of flux which can be obtained from us, and then relay it. The new spot, floated and rubbed down to the proper level, immediately becomes one piece with and has all characteristics of the surrounding floor, because it is the same floor.



Demands of extremely heavy duty being satisfactorily met by Johns-Manville Industrial Flooring in the shop of the De La Vergne Machine Co., New York.

Of particular interest is the tabulation of properties of various floorings shown on

page 188, which is the result of actual tests of all the materials mentioned.

This tabulation affords a direct comparison of the merits of Johns-Manville Industrial Flooring with others.

It is always dense, yet it has a certain amount of resiliency which prevents foot soreness and fatigue commonly caused by concrete and other non-yielding floor surfaces. Where employees of machine shops, factories and other operations are compelled to stand while at work this adds greatly to their comfort and efficiency. Furthermore, being dry and warm it is a protec-



tion against rheumatism and other ailments common to damp flooring conditions.

## Why Johns-Manville Industrial Flooring is Superior

It is tough and elastic, it will withstand extremes of temperatures far better than any other monolithic floor and will not chip, crack, crumble or craze under any ordinary conditions.

It is hygienic because it has no cracks or crevices to retain dirt, dust or germs. It is easily cleaned by flushing, dries quickly and is odorless.

Its fire retardant qualities and other points of superiority are brought out by the Underwriters' test, excerpts of which are shown on pages 189 and 190.

Where light or accurate machinery is in operation or merchandise is stored Johns-Manville Industrial Flooring is peculiarly satisfactory because it does not originate or hold dust. It is unequalled

for factory and warehouse use even under the heaviest trucking conditions and on account of its noiseless character is a boon where traffic conditions and the consequent noise is objectionable.

If your past experience has proved the old-fashioned types of flooring inadequate to your needs; if you are looking for a floor

which will give satisfactory service with the lowest maintenance cost, it is on those very points that Johns-Manville Industrial Flooring has made its greatest success. Its long wear and low up-keep are being proved every day in the year in many shop floors where the traffic is most severe and nothing



Thompson Chemical Laboratory, Williams College, Williamstown, Mass., where Johns-Manville Acid-proof Industrial Flooring was chosen for its many excellent qualities as well as its acid resistance.

but an exceptionally rugged floor could last. One notable example is in the Canadian-Pacific Ry. Shops, Calgary, Alberta, where 400,000 sq. feet—nearly ten acres—are in service, the largest floor area ever laid at one time with Industrial Flooring.

### PROPERTIES OF VARIOUS FLOORINGS

	Industrial Flooring	Common Brick	Paving Brick	Con- crete	Maple	Oak	Pine
1. Acid Resistance.....	100	80	100	50	30	33	30
2. Alkali Resistance.....	100	95	100	70	90	90	90
3. Durability .....	75	60	100	90	50	50	40
4. Elasticity .....	60	0	5	1	90	90	90
5. Fire Resistance .....	75	100	100	100	0	0	0
6. Non-Abrasion .....	95	0	30	10	95	95	88
7. Non-Slip .....	100	100	30	70	50	50	60
8. Quietness .....	75	10	5	5	50	50	60
9. Resilience .....	90	0	4	1	90	90	90
10. Sanitary .....	70	6	50	40	35	35	0
11. Thermal Insulation.....	60	10	0	5	90	90	90
12. Waterproof .....	100	0	10	60	25	25	25
Average .....	83.3	38.4	44.5	41.8	57.9	58.2	53.6

Note the very high average for Johns-Manville Industrial Flooring





We shall be glad to make a small installation knowing that the results will demonstrate conclusively the many advantages of Johns-Manville Industrial Flooring. Why not try this plan in some part of your plant where other floorings have not given proper service? It will afford an opportunity to make a personal test of Industrial Flooring where you can

convince yourself by actual use. Let us know your conditions. We will recommend the proper consistency and put in a test section. You will then be able to determine that it is **BEST BY TEST**.

Our Engineering Department will be glad to confer with you on any of your flooring problems.

### Johns-Manville Industrial Flooring as Fire Retardant

**M**ODERN building practice demands that as many of the materials as possible be fire-resisting to the greatest possible degree. The following facts on Johns-Manville Industrial Flooring will answer your most searching questions as to its ability to retard fire.

A few years ago the National Board of Fire Underwriters completed exhaustive tests to determine the fire-retardant qualities of Johns-Manville Industrial Flooring.

The following excerpts from their report (dated August 21, 1917) substantiate our claims for our Flooring as a fire-retardant and the excerpts are vitally important to every one interested in flooring for industrial and mercantile plants, public and private institutions, shops, breweries, packing houses, laundries, railway buildings and all floors where the service is particularly severe.

Under the heading of "Fire-Resisting

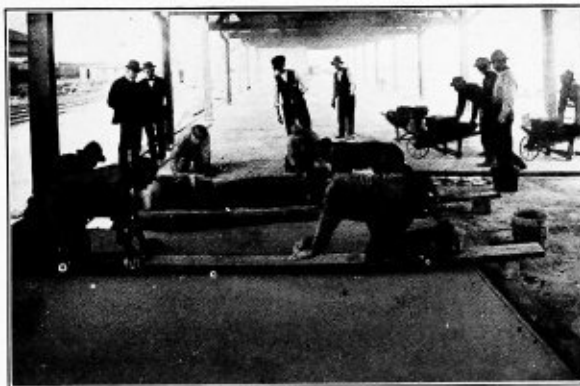

Showing how Johns-Manville Industrial Flooring is laid. The care used in selecting and mixing the proper materials for each condition and the skill of these workmen in application assures uniform results and satisfactory service.

Properties" the report of Underwriters' Laboratories, Inc., says of Johns-Manville Industrial Flooring:—

"The top flooring is not readily inflammable and does not carry or communicate fire to any material extent. It disintegrates slowly under heat, affords very considerable heat insulation to the floor structure and the progressive disintegration does not ma-

terially reduce the insulation afforded.

"By comparing a sample of the 'Industrial' top flooring with a sample of the maple flooring, it will be seen that the maple flooring was readily inflammable and carried and communicated fire to a material degree, giving off flame in considerable volume and more or less smoke. By referring to the logs of tests it will be seen that flames developed on the maple sample in 1 minute and 45 seconds after which it burned readily and spread rapidly, reaching the unexposed end of the sample in 20 minutes.

"In the case of the 'Industrial' sample, flame developed in 5 minutes and 50 seconds and spread slowly, giving off short, intermittent flames. At the end of the test (1 hour and 10 minutes), it had only reached to a point 6 feet from the exposed end of the sample. At the end of the test,



after the exposing flames had been extinguished and the gases of combustion given off from the wood at the edges of the sample had been quenched with water, the surface of the sample ceased to burn."

In addition to their findings concerning

the fire-resisting qualities of Industrial Flooring the Underwriters' Laboratories, Inc., also included in their report much interesting data on its design, construction, practicability, durability, etc. Quotations follow:—

### Design and Construction

"The design and construction of the top flooring are suitable for the purposes intended. The materials are suitable for the purpose, forming a homogeneous mass which can be readily installed under ordinary service conditions."

### Practicability

"It is practical to prepare the materials as furnished to the job and to apply them in the manner advocated. The flooring can be easily repaired or maintained if repairs and maintenance are required."

### Durability

"All floorings examined in the field were subject to hard usage and in no case was there any apparent deterioration from the effects of wear.

"In none of the installations examined was there any evidence of deterioration in the top flooring due to expansion, contraction or settlement of the building. In only one of the installations examined was the top flooring exposed to the elements, but this installation appeared to be in good condition.

"While the investigation did not give positive evidence to the effect that the top floor has no deteriorating influence on the floor structure, a

knowledge of the materials used indicates that if anything the top flooring should have a preservative effect.

"Although the floorings were carefully examined for cracks which would ordinarily indicate failure of the surfacing to conform to the expansion and contraction of the main flooring in which it rests, no cracks were discovered, indicating that the surfacing is not open to criticism in this particular. In only one of the installations examined was the flooring exposed to the elements, but no criticism developed in the case of this installation."

### Accident Hazard

"This flooring material, by offering a relatively high resistance to slipping, should reduce the accident hazard due to this cause.

"The examination of the material indicated a structure presenting a suitable anti-slip surface both when new and worn.

"The friction tests brought out results comparing favorably with results of test on anti-slip surfaces which have proven to be effective in reducing accidents due to slipping.

"Examination made in the field showed no marked difference in the resistance to slipping after being subject to actual service conditions."

## Approved as Non-Combustible by Columbia University Tests

As the result of recent tests performed on Johns-Manville Industrial Flooring at Columbia University, approval has been received from New York Bureau of Buildings in the various Boroughs of the City of New York for the use of this material as a

fireproof floor covering where non-combustible and fire-retardant materials are required, where same is supported on approved floor construction. Copies will be furnished upon request.



# Johns-Manville Industrial Flooring

## Specifications for

### Standard Industrial Flooring over Concrete or Wood

The Johns-Manville Standard Industrial Flooring Blocks shall be delivered on the ground, plainly marked with the brand and broken up before being placed in the kettles. There shall then be added the proper percentage of Asphalt Flux and both allowed to cook until the blocks are entirely melted. The proper percentage of mineral aggregate shall then be added and thoroughly mixed into the mass by the use of iron stirring rods and the temperature of the mixture brought to 450 deg F. The material shall be frequently stirred to prevent burning and then removed from the kettles in oak buckets or all iron wheelbarrows and taken to the work as required.

The mineral aggregate shall be thoroughly dry before being introduced into the mix and shall be a clean well graded material of a size to meet the particular service conditions encountered. The mineral aggregate is to consist of sharp coarse sand, gravel, trap rock or any crushed stone of sufficient hardness.

This flooring shall be laid to an average thickness of (*note that Industrial Flooring can be laid in any thickness from 1" to 3". The thickness required for the service conditions covered by these specifications to be inserted here*), spread with wood floats and sufficient pressure applied to eliminate all voids and blowholes. When the joints are made, place the hot mixture over the cold edge of the joint already on the floor and allow it to remain until the same is thoroughly heated. The surplus material shall then be cut

off and the joints made compact and tight by rubbing with wood floats.

— or —

This flooring shall be laid in two courses to a total average thickness of (*note that Industrial Flooring can be laid in any thickness from 1" to 3". The thickness required for the service conditions covered by these specifications to be inserted here*). It shall be spread with wood floats in such a manner as to avoid bringing the joints in the two courses directly over each other. These joints shall be lapped at least 12" and sufficient pressure applied to eliminate all voids and blowholes. When the joints are made, place the hot mixture over the cold edge of the joint already on the floor and allow it to remain until same is thoroughly heated. The surplus material shall then be cut off and the joints made compact and tight by rubbing with wood floats.

The top surface of the floor shall be given a sand finish in the following manner:—The top surface, while hot, shall be sprinkled with a fine sharp sand, which shall be thoroughly rubbed into the surface of the flooring and the surplus sand allowed to remain on the floor until the same is put in use.

In case of a cement finish the top surface shall be sprinkled and rubbed with fine sharp sand, which shall then be swept off while the material is still warm. The surface shall then be dusted with Portland Cement and same thoroughly rubbed in.

## Preparation of Floor Surface

*(To be incorporated in Mason's Specifications)*

After the concrete base has been placed and pitched, if necessary, to the proper grade for drainage, it shall be given a screeded and floated surface free from all sharp projections or offsets of any character except those shown on the plans. The concrete shall then be allowed to set and dry out.

*(To be incorporated in Carpenter's Specifications)*

The wooden sub-base shall be securely nailed and free from loose ends, or sharp projections and pitched, if necessary, to proper grade for drainage. It shall be of sufficient strength to support the loads contemplated.





# Johns-Manville Industrial Flooring

## Specifications for

### Acid-Resisting Industrial Flooring over Concrete or Wood

The Johns-Manville Acid-Resisting Industrial Flooring Blocks shall be delivered on the ground, plainly marked with the brand and broken up before being placed in the kettles. There shall then be added the proper percentage of Asphalt Flux and both allowed to cook until the blocks are entirely melted. The proper percentage of mineral aggregate shall then be added and thoroughly mixed into the mass by the use of iron stirring rods and the temperature of the mixture brought to 450 deg. F. The material shall be frequently stirred to prevent burning and then removed from the kettles in oak buckets or all iron wheelbarrows and taken to the work as required.

The mineral aggregate shall be thoroughly dry before being introduced into the mix, and shall be a clean and well graded material of a size to meet the particular service conditions encountered. The mineral aggregate is to consist of fine silica sand, silica pebbles, certain trap rock or any crushed stone or granite of sufficient hardness and which is immune to the action of all commercial acids, except hydrofluoric.

The flooring shall be laid to an average thickness of (*note that Industrial Flooring can be laid in any thickness from 1" to 3". The thickness required for the service conditions covered by these specifications to be inserted here*), spread with wood floats and sufficient pressure applied to eliminate all voids and blowholes. When the

joints are made, place the hot mixture over the cold edge of the joint already on the floor and allow it to remain until the same is thoroughly heated. The surplus material shall then be cut off and the joints made compact and tight by rubbing with wood floats.

— or —

This flooring shall be laid in two courses to a total average thickness of (*note that Industrial Flooring can be laid in any thickness from 1" to 3". The thickness required for the service conditions covered by these specifications to be inserted here*). It shall be spread with wood floats in such a manner as to avoid bringing the joints in the two courses directly over each other, and these joints shall be lapped at least 12" and sufficient pressure applied to eliminate all voids and blowholes. When the joints are made, place the hot mixture over the cold edge of the joint already on the floor and allow it to remain until same is thoroughly heated. The surplus material shall then be cut off and the joints made compact and tight by rubbing with wood floats.

The top surface of the floor shall be given a sand finish in the following manner:—The top surface while hot shall be sprinkled with a fine sharp silica sand, which shall be thoroughly rubbed into the surface of the flooring and the surplus sand allowed to remain on the floor until the same is put in use.

## Preparation of Floor Surface

*(To be incorporated in Mason's Specifications)*

After the concrete base has been placed and pitched, if necessary, to the proper grade for drainage, it shall be given a screeded and floated surface free from all sharp projections or offsets of any character except those shown on the plans. The concrete shall then be allowed to set and dry out.

*(To be incorporated in Carpenter's Specifications)*

The wooden sub-base shall be securely nailed and free from loose ends, or sharp projections and pitched, if necessary, to proper grade for drainage. It shall be of sufficient strength to support the loads contemplated.





## Johns-Manville Industrial Flooring for Battery Rooms

The conditions in all Battery Rooms require a flooring which will be absolutely immune to the action of the acids used, thereby eliminating for all time the possibility of the sub-structure becoming affected and weakened. Furthermore, particularly in Public Utility Stations, the top flooring must withstand the static load of

the batteries without showing any appreciable settlement of the battery supports into the floor surface. With these peculiar features in mind the following is a brief outline of the specifications which have been adopted by the Electric Storage Battery Co., the New York Edison Company and the New York Telephone Company.

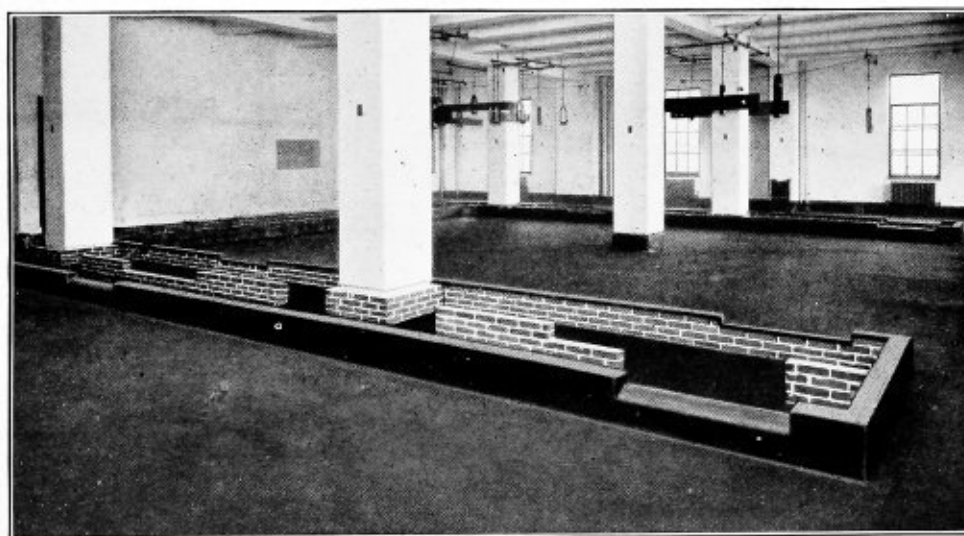

Typical installation of Acid-resisting Industrial Flooring in the battery room of the Triangle Exchange, New York Telephone Company, Brooklyn, N. Y.

### Specifications

**Lower Acid-proof Membrane.** Over the dry and smooth finished concrete floor which has been provided with the necessary pitch to drain, apply a coating of Concrete Primer. After same has dried for at least twenty-four hours apply a coating of Waterproofing Cement which has been heated to approximately 450 deg. F. In this hot Waterproofing Cement lay a ply of light weight Wool Felt lapped 3". Then apply another mopping of Waterproofing Cement into which lay a second ply of light weight Wool Felt, sheets lapped 3", this second layer to receive a top mopping of waterproofing cement. These two plies of felt to extend up walls and columns at

least 4" where a 6" base is to be installed and at least 8" where a 12" base is required.

**Oil Paper—Slip Joint.** Over this membrane there shall be applied two layers of 50 lb. 36" oiled Kraft Paper each lapped 3", this for the purpose of providing proper slip joint between Waterproofing and Industrial Flooring. This paper is not to be turned up at walls or columns.

**Upper Acid-proof Membrane.** The Upper Acid-proof Membrane consisting of one ply of light weight wool felt shall be laid over the oiled Kraft Paper dry, with only the 3" laps sealed with Waterproofing Cement; the felt to be turned up and stuck on walls the same as for lower membrane.



**Industrial Flooring.** The wearing surface to be laid in two layers each approximately  $\frac{3}{4}$ " thick, with the joints of the second coat breaking at least 12" with the joints of the first coat. The Industrial Flooring shall consist of acid-resisting bituminous blocks with proper mineral ingredients, the balance of mineral to be incorporated on the job shall be of White Quartz or Silica variety and a natural asphalt flux. All of these materials as well as the wool felt and waterproofing cement shall be absolutely unaffected by dilute sulphuric of 1400 deg. specific gravity. Samples of all materials to be tested and approved by owners before being used in the floors.

The materials to be mixed to a proper consistency and brought to a temperature of approximately 450 degrees before applying; the hot mixture must be not lower than 400 deg. F. while being applied on the floor. The second layer to be rubbed smooth with fine finishing sand, particular attention being given to obtaining perfectly tight joints and a surface free from voids.

**Test for Hardness—New York Telephone Company Requirements:**

The finished floor shall be tested by contractor at two different locations as described by the

architect. The room temperature of not less than 90 deg. F., reading taken 5 ft. from the floor, must be maintained in the room twelve hours before test weights are to be applied. After the room has been subjected to this temperature for twelve hours, the test weights are to be set and the floor must be able to support for twenty-four hours 1620 pounds supported on a 9" square tile without showing more than  $\frac{1}{16}$ " depression with a *floor temperature* of not less than 90 deg., which is to be held while test weights are on the floor.

**Test for Hardness—New York Edison and Electric Storage Battery Requirements:**

Tests required by these interests require the floor to withstand a load of 4000 lbs. on 16 square inches for twenty-four hours without showing a depression of over  $\frac{1}{16}$ " at *room temperature* of 77 deg. F.

**Base and Cove.** A base and cove 6", 9" or 12" high by approximately 1" thick, as required, to be applied along walls and columns. This base to be plastered against a metal lath to be installed by the contractor, extreme care being exercised to obtain thorough bond and acid tight joint between the surface of the floor and cove and base.

## Johns-Manville Asphalt Boat Deck Covering

In order to eliminate the constant expense of removing and replacing paint protective coatings on steel decks of car-floats, tugs, vessels, etc., applied for the purpose of preventing rust and corrosion, we have prepared a deck covering com-

posed of Waterproofing and Deck Covering materials as indicated in the following specifications. This material has been successfully used on a number of New York Central Railroad car-floats.

### Specifications

**Preparation of Surface.** The surface of the metal shall be made free from rust, corrosion, paint or grease and cleared of all debris or other obstructions not a part of the deck construction.

**Application of Material.** After the surface of the steel has been thus prepared by others, there shall then be applied a heavy coating of Johns-Manville Asphalt Primer, this Primer to be allowed to dry for at least twelve hours. Directly over the Primer Coat there shall then be applied one layer of 14 lb. Asbestos Waterproofing Felt

laid in a hot mopping of Johns-Manville Waterproofing Cement. This Felt to be laid free from folds and wrinkles. Over the surface of the felt shall be applied Johns-Manville Boat Deck Covering in thicknesses ranging from  $\frac{3}{4}$ " to  $1\frac{1}{2}$ ", depending upon conditions to which the deck covering will be subjected, applied in one or two coats as conditions may require.

The preparation of the material used for this particular service to be similar to that indicated under standard specifications on page 191.

# Johns-Manville Waterproofing and Damp-proofing Materials

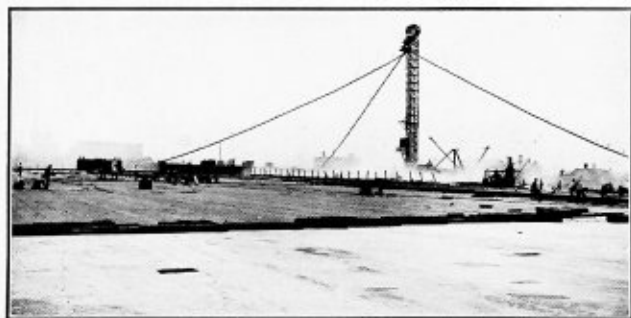



## Waterproofing—What It Is

**W**ATERPROOFING is a broad term often misapplied and misunderstood. In reality waterproofing should only be thought of in the presence of seepage or where there is actual water pressure arising from such seepage and pressure conditions. Every other case of "waterproofing" properly comes under the head of Damp-proofing. For these conditions Johns-Manville can supply you the proper materials for either prevention or correction.

### Damp-Proofing

Damp-proofing is protection against moisture where no actual water pressure is encountered. It is simply the prevention of dampness penetrating walls or floors.

### Two Methods of Waterproofing, Integral and Membrane

It is an accepted fact among engineers and architects that there are but two methods of waterproofing, but it has been proven that **ONLY ONE** of them is capable of giving permanent, positive results.

### The Integral Method— Why It Fails

This method provides for the incorporation of a powder, paste or liquid into the concrete during its construction. It is mixed with the cement, becomes part of the mass and is supposed to add to the density of the concrete to such an extent as to prevent the seepage of water.

It fails when hair cracks or larger openings develop in the concrete, due entirely to expansion and contraction or unequal settlement in the structure. The Joint Committee on the Waterproofing of Con-

crete recommends abandoning this method.

### The Membrane Method— Why It Succeeds

This method provides for the application of a protective bituminous skin or membrane over the surface to be waterproofed as shown in details on page 200. The membranous covering of waterproofing asphalt, reinforced with suitable fabric or felt or both, is strong and flexible and has the necessary characteristics to resist water pressure and enough "give" to bridge over hair cracks in the concrete due to temperature changes.

The membrane is built up in as many plies of reinforcing material as is necessary to meet the conditions, and these plies are bonded together and to the concrete with asphalt cement.

It is conceded that a carefully combined asphaltic compound is the most effective and durable waterproofing substance in existence. As the base of all Johns-Manville Waterproofing materials we have chosen Gilsonite which is the purest form of asphalt known. However, in spite of its great purity, Gilsonite requires special preparation before it can be successfully used commercially. By our exclusive process of refining and combining other natural asphalts with Gilsonite, it is rendered remarkably ductile and adhesive, characteristics which adapt it more perfectly than any other material to withstand the peculiar and exacting conditions of service to which it is subjected.

### Johns-Manville Membrane Waterproofing

In selecting a material for waterproofing purposes, the first consideration is durability. Waterproofing that is not perma-





ment is a mere makeshift and actually worse than none at all because of the expense, inconvenience and loss of time in connection with correcting it, to say nothing of the damage generally caused by its failure.

Johns-Manville Membrane Waterproofing is the result of years of experience in

the successful waterproofing of every conceivable type of construction. It has been proven by actual experience to be the most economical, not in the first, but in the last cost, and the most satisfactory because **IT IS WATERPROOF—NOT APPROXIMATELY BUT ABSOLUTELY WATERPROOF.**

## Materials used in Johns-Manville Waterproofing

### Johns-Manville Concrete Primer

This is the first coating applied to the concrete, brick or stone surfaces which are to be waterproofed. It penetrates the surface to such an extent as to form an anchorage for the subsequent waterproofing. It also acts as a cleanser for the surface, preparing it for the asphaltic coatings to follow. The covering capacity of this material should run about 100 square feet to the gallon on comparatively smooth surfaces.

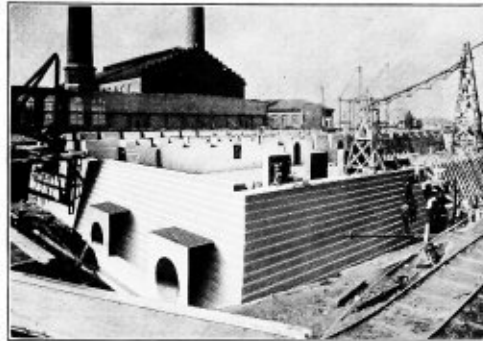

Showing typical application of Johns-Manville Waterproofing Materials to foundation walls of Buffalo Water Works, Buffalo, N. Y.

### Johns-Manville Asphalt Waterproofing Cement

This is applied while hot over the Primer and is used to cement the various fabrics together into one composite sheet. Owing to great care exercised during the process of manufacture, this bituminous material is absolutely uniform in character. It is 99.5 per cent pure and contains no matter that will disintegrate or decay. Proof against the action of cold acid, alkali, brine and water; very slightly affected by a wide range of temperatures between melting and brittle points. To apply this Waterproofing Cement it is heated to 450 deg. F. and mopped on while

hot. One ton of this material should cover 3000 square feet of surface  $\frac{1}{8}$  of an inch thick.

### Johns-Manville Asbestos Waterproofing Felt

Used as a reinforcement and to give body and substantiality to the membrane; cemented together and bonded to the concrete by the waterproofing cement. It is made of pure asbestos (rock fibre), thoroughly impregnated with pure asphalt. This is the only all-mineral felt made, therefore, the only material of its kind that is proof against water, cold acid, mold and decay, for all time. Virtually a pliable bituminized stone sheet. Furnished in two weights, 14 lb. felt in 3 square rolls and 35 lb. felt in 2 square rolls.

### Johns-Manville Asphalt Saturated Fabric

Used not only as a reinforcement for the membrane but to give added tensile strength. It is an especially strong cotton fabric or duck used in connection with Asbestos Waterproofing Felt in as many plies as are required to meet the conditions. Being a loosely woven material, the waterproofing cement, which is mopped



on hot, thoroughly impregnates, cements and bonds together the several plies of the reinforcement.

### Johns-Manville Self-Healing Waterproofing Cement

This is an asphaltic compound which carries a very low congealing point and a melting point of 125 deg. F., although we can furnish it with a melting point of 90 deg. F., when a softer material is desired. The use of this product is naturally limited for waterproofing purposes on account of its tendency to move readily under comparatively high temperatures and also its extremely viscous nature. For brine decks in packing-house hog-coolers and for waterproofing work between wooden floors, this material is ideal. We have also found that on account of its adhesiveness at low temperatures it makes an excellent expansion-joint filler and we are using it largely for that purpose. It is shipped in wooden barrels weighing approximately 500 pounds and half barrels weighing approximately 250 pounds.

### Johns-Manville Pickling Tank Cement

This is an asphaltic compound evolved principally for use in lining the inside of wood or concrete tanks where an acid-proof coating is a necessity. It is mopped on the surface in a heated condition and carries a melting point of 200 deg. F., although a softer material can be furnished

if desired with a melting point of 150 deg. F. In lining wooden tanks it is sometimes used to coat the tongues and grooves of the boards when the tank is being built, the boards being drawn tightly together and held in place permanently by the use of wooden dowels. After the tank is erected the inside is primed and given from two to four coats of the Pickling Tank Cement. It is immune to all the cold commercial acids, except hydrofluoric. It is shipped in iron drums weighing approximately 400 pounds.

### Johns-Manville Expansion Joint Filler

An asphaltic compound of great tenacity and elasticity. Used for filling expansion joints. It is capable of taking care of certain movement in structures, paving and road work due to expansion and contraction. It is melted and poured into place. Immune to the action of street acids. Shipped in iron drums of approximately 400 pounds each.

### Johns-Manville Bituminous Putty

This material is composed of an asphaltic compound and asbestos fibre, used as a filler to prevent the infiltration of water in recesses where a permanent seal is hard to maintain with the waterproof membrane. It forms an elastic bond but little affected by temperature change and vibration. Largely used in connection with certain types of bridge waterproofing where the waterproof membrane is sealed to the sides of the girders.

## Johns-Manville Damp-Proofing

In the large majority of cases the application of cold surface coatings will effectively damp-proof any structure. There are, however, special cases of damp-proofing which require the membrane method of waterproofing. We firmly believe, and

successful installations prove, that Johns-Manville Damp-proofing is the most efficient system to keep out dampness and to prevent discoloration due to the absorption of moisture.



### Johns-Manville Liquid Waterproof Coating

**T**HIS is used in connection with Johns-Manville Concrete Primer, and is applied cold in one or two coats, for damp-proofing only. It is used for wall work or for other surfaces not liable to injury from abrasion and where there is no hydrostatic pressure. It will withstand seepage of surface water and prevent the discoloration or staining of the outside face of concrete walls. It has a covering capacity over smooth surfaces of about 200 square feet to the gallon when used over the Primer.

### Johns-Manville Cut Stone Backing

This is used for coating the sides and back of cut stone to prevent discoloration and dampness of inside or interior walls. It should cover approximately 60 square feet per gallon over rough surfaces.

### Johns-Manville Aquadam

A black, waterproof, elastic, tacky material in liquid form. Applied directly to the inside of exterior walls, over brick, tile and concrete; prevents dampness from penetrating through the plaster, causing discoloration of decoration and warping of woodwork. This material is of thick creamy consistency and should be so applied.

**Plaster will bond securely to walls so treated.** Over all surfaces we would recommend two-coat work and at least twenty-four hours must elapse between the application of the first and second coats. After thoroughly coating the wall, allow twenty-four hours before application of the plaster and not more than one week, depending upon atmospheric conditions.

All Johns-Manville Waterproofing materials are sold on an f.o.b. basis, for application by the user or local contractor.



Applying Johns-Manville Waterproofing on side walls. See detail drawings on page 200.



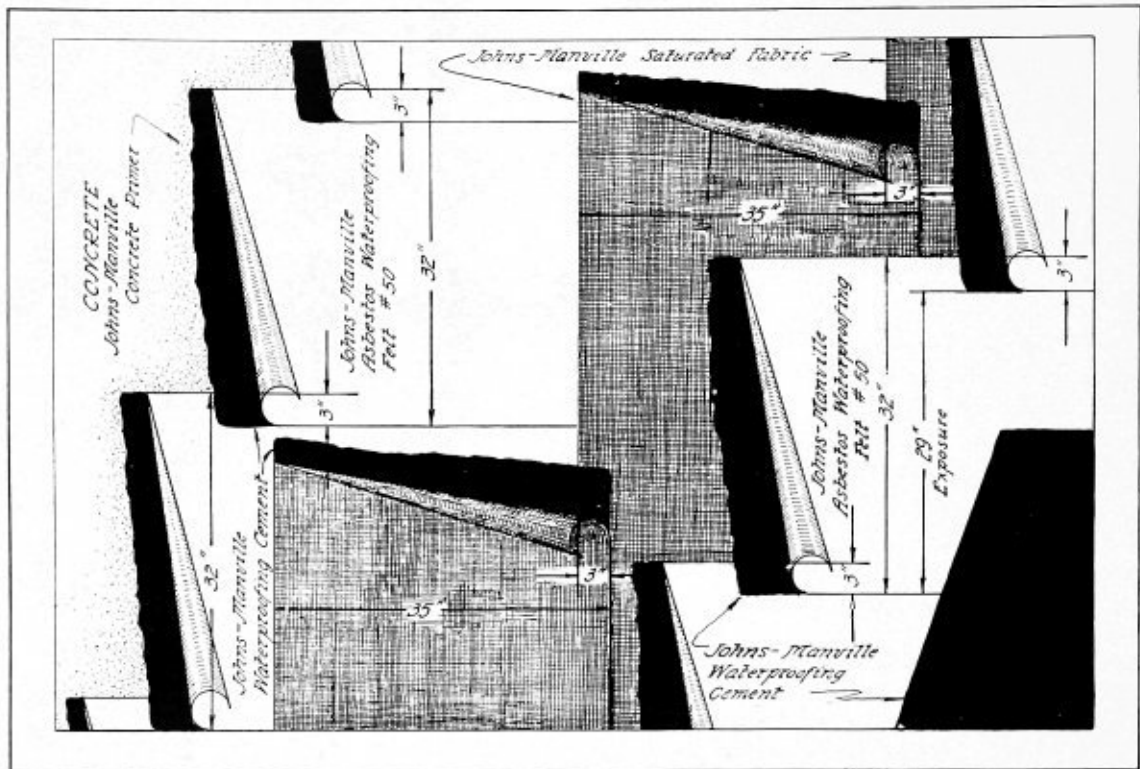

Details of application of 3-Ply Built-Up Waterproofing Membrane.

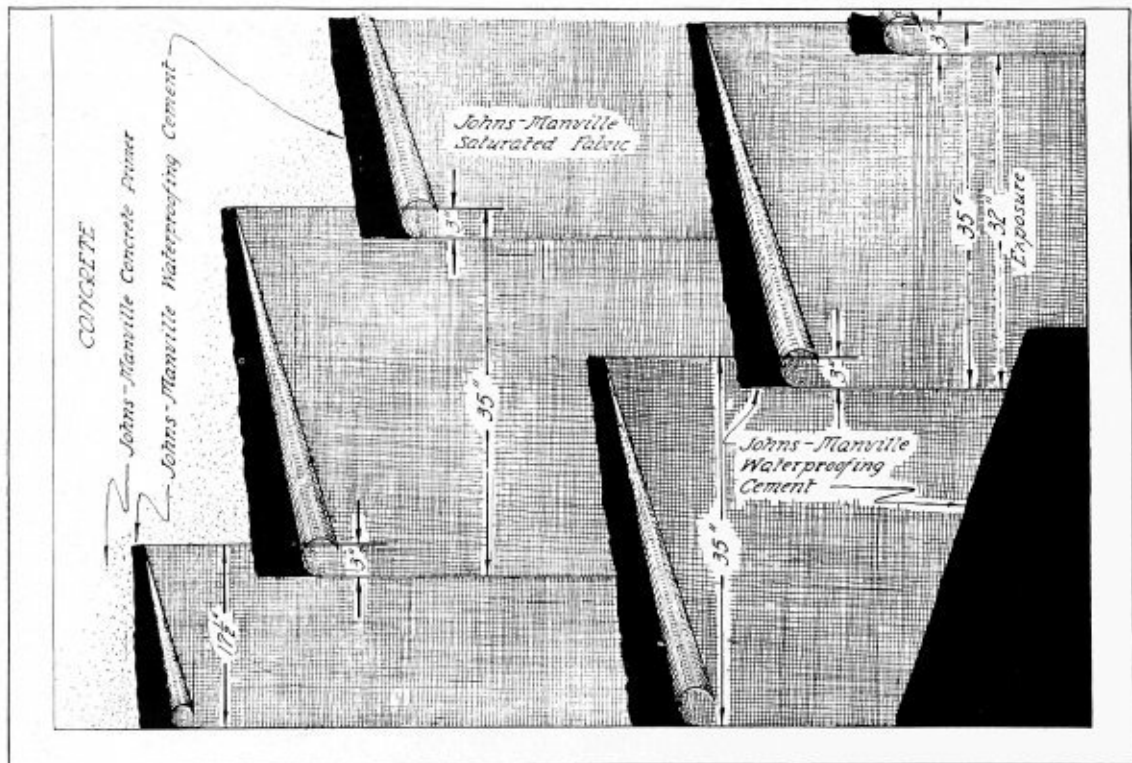

Details of application of 2-Ply Built-Up Saturated Fabric Waterproofing Membrane.



# Johns-Manville System of Acoustical Correction





# Johns-Manville System of Acoustical Correction

**F**OR the elimination of unnecessary and disturbing sounds, reverberation, echoes and poor acoustics in Offices, Banks, Hospitals, Restaurants, Theatres, Schools, Colleges, Auditoriums, Clubs and Hotels. The Acoustical Department of Johns-Manville Inc. is maintained for the purpose of conferring with architects and owners in the design and construction of new buildings to insure good acoustical conditions as well as to correct poor acoustics in structures already built. Through its System of Acoustical Correction the Johns-Manville Company is prepared to produce good hearing qualities in auditoriums of churches, theatres, court-rooms and other public buildings; also to reduce to the minimum the fatigue and loss of efficiency due to confusion and noise in offices, banks, hospitals and rooms of similar character, resulting from the unavoidable concentration of employees and noisy, mechanical office appliances.

In broad terms, good acoustics requires that there shall be no confusion or blurring of speech or music due to overlapping or interference of tones and syllables and that everything shall be done to bring about that clarity of tone which is consistent with the maintenance of sufficient loudness and proper balance. The acoustical conditions of any room are affected partly by size and shape, and partly by the character of interior surfaces and furnishings, as well as by the distribution and size of the audience or occupants.

A certain amount of absorption is necessary in every auditorium. In some cases furniture and the clothing of persons provide all that is needed in this respect, but more often artificial treatment is required



Johns-Manville Acoustical Correction on the ceiling of the Composing Room, New York Tribune. This scientifically designed corrective treatment reduces the annoyance, fatigue and loss of efficiency due to unnecessary sounds, echos, reverberations, etc.

and these factors must be carefully studied in every case. The nature of the treatment, its amount and location, is a matter for expert determination. The problems involved are highly technical and for their satisfactory solution the trained knowledge of specialists is indispensable.

Through the Johns-Manville Company, the services of competent acoustical engineers are available to architects and others who have acoustical difficulties to be overcome. The methods used are based on the scientific researches of the late Professor W. C. Sabine of Harvard University and the Johns-Manville Company has developed special materials and methods of application for producing the necessary correction.

The Johns-Manville engineering experts are prepared to examine plans and specifications at any time, without fee, and to recommend suitable treatment where it may be necessary.

# Johns-Manville Electrical Materials

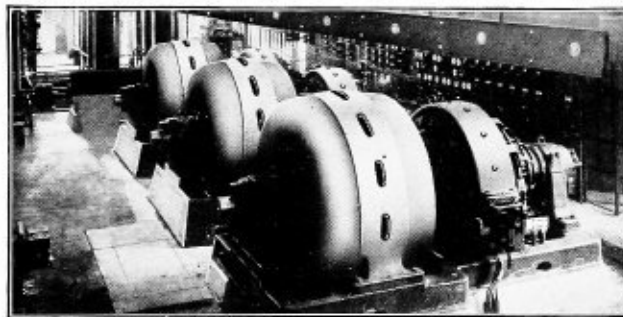



## Johns-Manville Ebony Asbestos Wood

Johns-Manville Ebony Asbestos Wood has been examined and approved by the Underwriters' Laboratories, Inc., under the direction of the National Board of Fire Underwriters.

**J**OHNS-MANVILLE Ebony Asbestos Wood is recommended for use as an insulating base for switchboards, panel boards, bus bar barriers, switch bases, insulators for collector rails on ore bridges and all kinds of cranes, charging and drawing machines in coke plants, third rails on top of coke ovens, etc. It is offered in the form of composition sheets made up of asbestos fibre and binding cements and densely impregnated under heat and pressure into a compound of very high dielectric strength.

This material possesses the least possible surface leakage, being affected neither by oil nor atmospheric moisture, nor will it rot or rust even when exposed to the action of water, gas, oil, chemicals or ordinary acids. Although comparatively light in weight, Ebony Asbestos Wood has great physical strength due to its fibrous structure, hence is free from ruptures due to rapid temperature changes. It will withstand heat up to a temperature of 500 degrees F. and is not likely to warp, shrink, crack or buckle under extreme service conditions. This strength is an important

factor when the loss due to handling more fragile materials is considered, and its lightness is in its favor both on the basis of mechanical strength and the saving of freight charges.

For years the chemical industry has been looking for an ideal material for laboratory table tops, sink tops, lining hoods over hot tables, and cabinet hood linings.

The perfect material would be one

which would be impervious to chemicals, acids and acid fumes, one that would not break glass containers on account of temperature change when they are put down while hot.

The ideal material has been discovered in Johns-Manville Ebony Asbestos Wood.

Johns - Manville Ebony Asbestos Wood is taking the place of slate, porcelain and Alberene stone in hundreds of plants for hundreds of different uses.

On the next page there are shown some typical uses of Johns-Manville Ebony Asbestos Wood in industrial plants. There are uses in your plant—find them—and increase your production by reducing breakdowns to the minimum.



Sections of switchboards at United Electric Light & Power Co., Hell Gate, New York City, one of the most modern power stations in the world. Johns-Manville Ebony Asbestos Wood was chosen for the huge switchboards and many other uses because of its superior dielectric strength, ability to withstand vibration and shock and freedom from metallic veins.





## Some Typical Uses for Ebony Asbestos Wood

Disconnecting switch bases for lightning arresters	Charging rheostats	Lightning arrester boxes	Cabinets for distant control of oil switches	Linings of cabinets
Primary fuse boxes	Theatre pockets	Panels for switchboards	Converter panels	Mercury arc rectifier panels
Washers to separate bus rings	Theatre expansion plugs	Switch barriers	Barriers to separate units	Solenoid switches
Terminal blocks, motor and generator	Theatre boxes and clusters	Faces for rheostats of all kinds	Wire cleats	Back connected switches
Back board controllers	Button switch boxes	Electric elevator controls	Divider cleats	Cabinets
	Wattmeter bases	Shunt bases	Bus bar supports	Small wire holders for instrument connections
	Ground, petticoat and line insulators	Fuse blocks	Resistance boxes	Dinkey controllers
		Exciter panels	Distributing boards	

### INSULATION RESISTANCE IN MEGOHMS PER SQUARE INCH OF SURFACE, AT 18° C.

Thickness	Resistance As Received, Megohms	After 96 Hours Immersion, Megohms	Thickness	Resistance As Received, Megohms	After 96 Hours Immersion, Megohms
1/8"	475,000	50,000	3/4"	3,500,000	3,000,000
1/4"	1,700,000	1,000,000	1"	4,000,000	Above 3,000,000
3/8"	2,500,000	1,500,000	1 1/4"	5,000,000	Above 3,000,000
1/2"	3,000,000	1,900,000	1 1/2"	6,000,000	Above 3,000,000
5/8"	3,200,000	2,500,000	2"	7,500,000	Above 3,000,000

### TABLE OF COMPARATIVE PHYSICAL PROPERTIES OF SWITCHBOARD MATERIALS

	B-V Marble	Slate	Soapstone	Johns-Manville Ebony Asbestos Wood
Weight per cubic foot.....	180 lb.	180 lb.	175 lb.	121 lb
Dielectric strength one inch in thickness.....	65,000 V	8,000 V	25,000 V	76,000 V
Insulation resistance per one inch cube.....	170,000 meg.	25 meg.	250 meg.	4,000,000 meg.
Crushing strength per square inch.....	13,000 lb.	10,000 lb.	8,000 lb.	15,000 lb.
Transverse modulus of rupture in lbs. per sq. in..	890 lb.	6,200 lb.	1,300 lb.	3,500 lb.

NOTE:—The figures in this table are the values obtained by actual test, and care should be taken not to use the strengths given, in construction, without a suitable factor of safety. The insulation resistance and puncturing voltage of slate, marble and soapstone are only approximate, since individual specimens of the same kind vary 500% among themselves.

The preceding table has been computed on the basis of tests made in the dry state and the materials are considered to have absorbed no moisture. The results would be different if figured on the basis of absorption, with the exception of soapstone and Johns-Manville Ebony Asbestos Wood, which are practically unaffected after immersion in water for any length of time. The result on marble and slate would be considerably reduced after immersion in water.

### PUNCTURING VOLTAGE

Thickness	Puncturing Voltage Average	Thickness	Puncturing Voltage Average	Thickness	Puncturing Voltage Average	Thickness	Puncturing Voltage Average
1/8"	12,900	1/2"	37,000	3/4"	54,000	1 1/4"	80,500
1/4"	25,500	5/8"	43,000	1"	66,000	1 1/2"	85,000
3/8"	30,500					2"	96,000

### WEIGHTS AND LIST PRICES

This material is supplied in standard size sheets 35" x 48", 42" x 48" and 42" x 96" in the following thicknesses:

Thickness	Weight per Square Foot	List Price per Square Foot	Thickness	Weight per Square Foot	List Price per Square Foot
1/8"*	1.50 lbs.	\$0.90	3/4"	7.85 lbs.	\$2.50
1/8"	2.08 "	1.20	7/8"	9.00 "	2.65
1/4"	2.75 "	1.30	1"	10.35 "	2.80
3/8"	3.50 "	1.45	1 1/4"	12.85 "	3.10
1/2"	4.25 "	1.60	1 1/2"	15.00 "	3.65
5/8"	5.43 "	1.90	1 3/4"	17.80 "	3.95
	6.88 "	2.35	2"	20.65 "	6.20

Prices on thicknesses above 2" on application. \* Supplied only in sheets 36" x 48".



## Johns-Manville Moulded Ebony Insulation

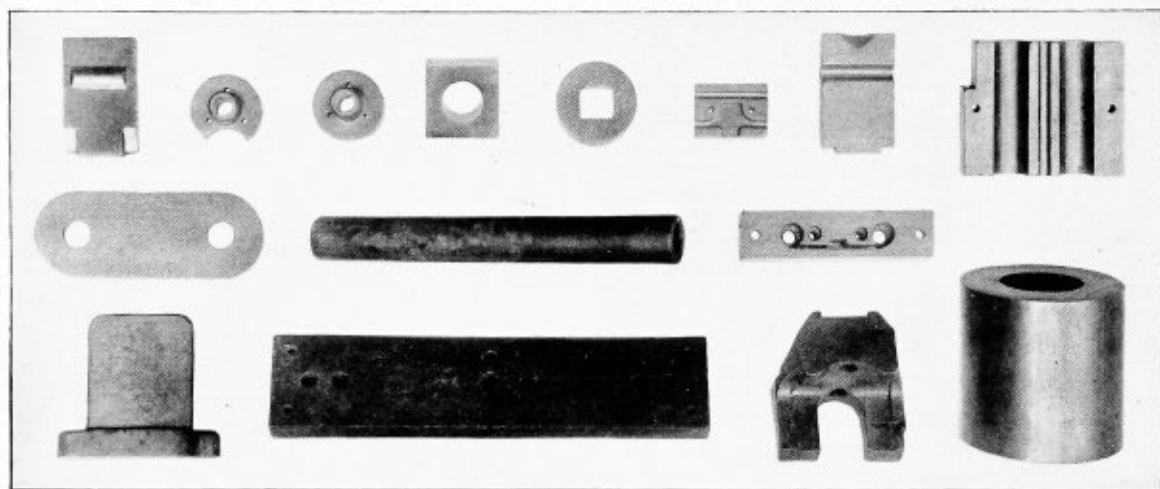

Moulded Ebony saves expensive machining on small pieces of insulation and provides highly efficient and durable protection.

**M**OULD<sup>E</sup>D Ebony Insulation is a newly developed material made of the same ingredients and under the same method of manufacture as Ebony Asbestos Wood with the exception that it may be pressed into a variety of forms instead of being limited to sheets.

Its properties are similar to sheet Ebony Asbestos Wood. It will withstand ordinary acids, may be used under conditions involving moisture or vapor, and has a safe working temperature limit of about 200° C. It has the dull, jet black finish so much desired by panel board manufacturers. It will not take the high polish of Bakelite but has practically equal electrical characteristics, will withstand vibration and shock better and may be drilled and machined much easier. It should not be classed with so-called "cold moulded" insulation. Its base is high grade asbestos fibre and cement and it will not deteriorate with age nor absorb moisture, thus obviating the current leakage so common with more porous cold-moulded material.

Its principal use is for small panels of not greater than 144 square inches, in  $\frac{1}{2}$ " thickness, and 400 square inches in thicknesses from  $1\frac{1}{4}$ " to 2". Such panels may be furnished accurately moulded at a great saving over finishing like pieces in hard fibre, marble, slate or other slab or sheet material, where machine work is involved. It is stronger electrically than any of the above and stronger mechanically than either slate or marble.

It is adaptable for panels, switch, rheostat and fuse bases, terminal blocks, insulating segments on electro-magnets, etc., and may also be used for handles or bases for steam gauges or instruments.

**NOTE:**—Lateral holes and recesses or spiral threads are impracticable to mould. Walls generally should be not less than  $\frac{1}{4}$ ".

For quotation, sample, model or drawing should be submitted together with allowable tolerance and monthly or daily production necessary; also total quantity on which quotation is desired. A moderate preliminary charge is made to cover the manufacture of a mould, which charge varies according to the complexity of the design. Rounded edges are generally more expensive to mould than square ones. If square edges can be substituted for round in design, please so state.



# Johns-Manville Transite Asbestos Wood

Examined and approved by the Underwriters' Laboratories Inc.,  
under the direction of the National Board of Fire Underwriters.

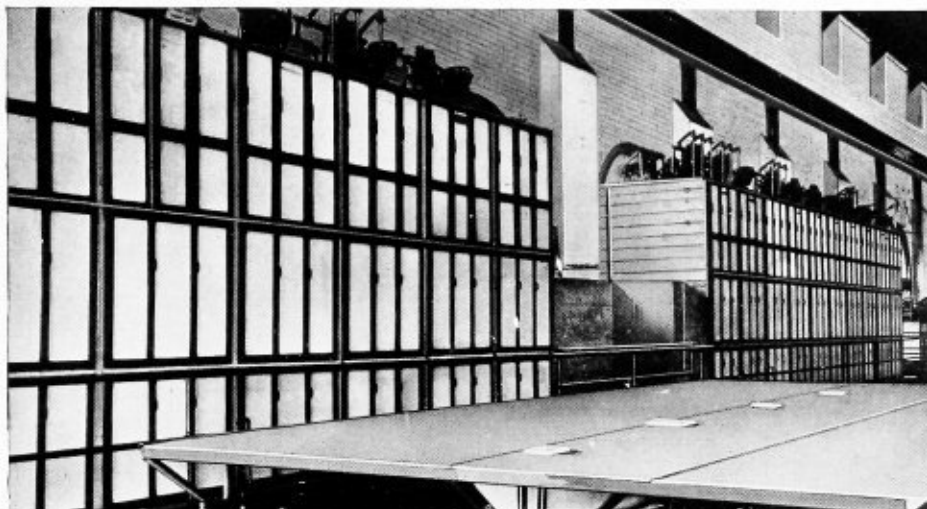

Oil switch compartments and transformer protective cover of Transite Asbestos Wood.  
Installed at Station F, Pacific Gas and Electric Co., San Francisco, Calif.

**J**OHNS-MANVILLE Transite Asbestos Wood is recommended for general electrical construction use, and is most satisfactory where fireproof, heat-resisting material is required and great dielectric strength is not necessary. It has proven to be most durable for bus bar barriers, transformer doors, fireproof lining or containers and other forms of construction throughout the plant where long-continued, positively fireproof service is essential.

Transite Asbestos Wood can be fastened with nails or screws, takes any kind of a wood finish, yet withstands successfully the most severe fire tests and sudden changes of temperature. Will not warp or become distorted or weakened in service; in fact, it actually becomes tougher with age.

Supplied in sheets 36" x 48", 42" x 48" and 42" x 96" in various thicknesses from 1/8" to 2".

## Some of the Electrical uses of Transite Asbestos Wood

Bases and floors about switchboards	Shunt bases	Resistance boxes	Barriers to separate units
Washers to separate bus rings	Potential transformer boxes	Charging rheostats	Wire cleats, large and small
Troughs about wires	Frames for small boards	Equalizer bases	Separation plates for street car controllers
Lightning arrester boxes	Protection from magnetic blow-outs on railway cars	Fuse boxes	Electric elevator controls
Switch barriers		Panel board liners	
		Wattmeter bases	

For uses and application of Transite Asbestos Wood for building purposes see page 170.

### WEIGHTS AND LIST PRICES OF FLAT TRANSITE ASBESTOS WOOD

Thickness in inches	Weight per sq. ft.	Price per sq. ft.	Thickness in inches	Weight per sq. ft.	Price per sq. ft.	Thickness in inches	Weight per sq. ft.	Price per sq. ft.
1/8	1.7 lbs.	0.15	3/8	4.0 lbs.	0.45	1 1/2	13.0 lbs.	1.50
1/16	2.1 "	0.225	1/2	5.3 "	.60	1 3/4	15.7 "	1.80
3/16	2.8 "	.30	5/8	7.6 "	.90	1 7/8	18.5 "	2.10
1/4	3.4 "	.38	1	10.1 "	1.20	2	21.0 "	2.40



## Orangeburg Fibre Conduit

Manufactured by THE FIBRE CONDUIT CO., Orangeburg, N. Y.

JOHNS-MANVILLE INC., NEW YORK CITY  
SOLE SELLING AGENT

**O**RANGEBURG fibre conduit is a hard, tough conduit, cylindrical in section. In manufacturing Orangeburg Fibre Conduit, Bends and Fittings wet wood pulp fibre is formed on a mandrel to the desired length and thickness of wall. The individual fibres become felted into and form a solid, homogeneous wall. Taken off the mandrel, the wet pulp structure is subjected to a drying process, after which it is placed in a vat of bituminous impregnating liquid compound. There are sufficient creosote salts in the compound to kill any vegetable matter or bacteria that might cause decay. This compound is therefore a thorough preservative and is also insulation and waterproofing. It thoroughly permeates the entire structure, so that after treatment the wall of the conduit, when cut, presents a strong resemblance to hard rubber. The ends are tooled in a lathe to make Socket or Harrington joint, as may be desired. Stock is stored in winter and summer in the open yards of the manufacturing plant.



### Standard Specifications—General

1. It shall be thoroughly impregnated with insulating compound.
2. The walls shall be compact and incapable of separation into layers when heated to 212° Fahr.
3. The material shall not be affected by acids which may be present in the ground and shall itself be free from any substances which might corrode the sheath of leaded cable.
4. The bore shall be straight, the cross-section shall not vary at any point more than 1/8" from a true circle and

the inner surface shall be free from dents or other obstructions, as gauged by ability to pass a 36" long mandrel of 1/4" less diameter than the nominal size of the conduit.

5. The inner surface shall be free from any considerable excess of compound and from rough or flaky areas.

6. On sizes from 2" inside diameter to 4 1/2" inside diameter, lengths shall be 5 ft., with the exception of not more than 15% which may be furnished in lengths shorter

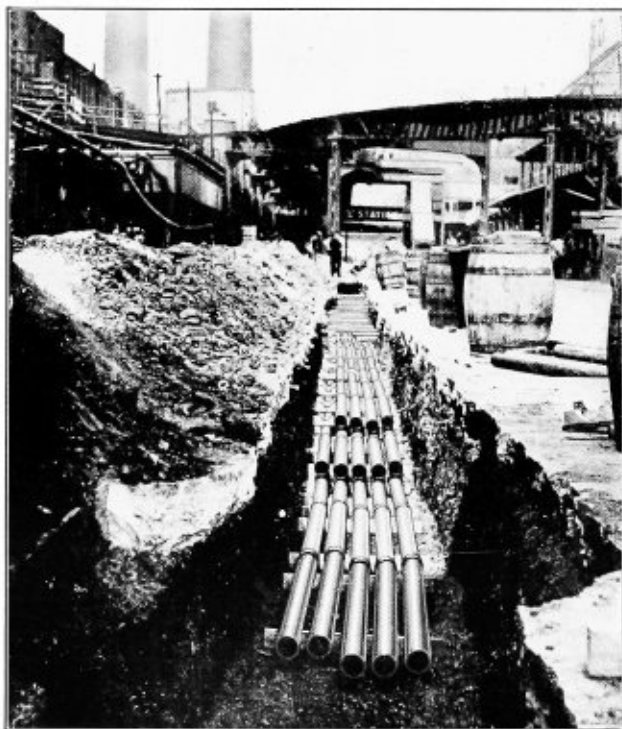

Fibre Conduit installation by "built-up" method. Grooved moulded concrete separators hold tiers of conduit in position to pour concrete in a single operation.





than 5 feet but not less than 3 feet. On 1" size, lengths are 2 feet and 2½ feet, and on 1½" size we will furnish not less than 60% 5 foot lengths and not more than 40% lengths 36" and upwards.



## The Harrington Joint Type

This type of joint is made with both ends tapered. The sleeves are also tapered, thereby allowing more "swing" to the conduit than can be secured by other types of joints. With this type the conduit does not butt, permitting greater flexibility.

## Types of Joints

Orangeburg Fibre Conduit, Bends and Fittings are made with two types of joints; namely, Socket and Harrington. Each type has its advantages for certain different types of applications. List prices are given in the succeeding pages. Prices and promises of delivery on special material can be secured from the nearest Johns-Manville Branch.

## The Socket Joint Type

The socket or mortise and tenon connections that are cut on the ends of each length of Socket Joint Orangeburg Fibre Conduit are automatically turned, slightly tapering and uniform in size.

As the joints are automatically formed, the connection secured in laying the conduit is perfect in fit and alignment. The inside of the joint is reamed during the process of cutting so that there can be no offset at the joints when laid.

The flange of this joint also serves to exclude the cement when concrete is poured.

## Special Sizes of Fibre Conduit

Fibre conduit can be made on special order up to 18 inches in inside diameter. For prices and delivery on special material apply to the nearest Johns-Manville Branch.

## Special Bends

Special bends can be formed to dimensions desired, within the limits given in the table below, if not mitred. If mitred any degree or radius desired may be obtained and the bend can be made anywhere in length of standard pipe.

These bends are made only to order.



Fibre Conduit incorporated in retaining wall.

### 45° and 90° BENDS

I. D. in Inches	Not Mitred Shortest Radius Inches
1	8
1½	12
2	18
2½	24
3	30
3½	36
4	36
4½	36

### "S" BENDS

I. D. in Inches	Max. off-set, Ins.	Not Mitred Radius, Inches
1	16	8
1½	36	18
2	36	18
2½	28	24
3	24	36
3½	20	36
4	20	36
4½	20	36



## Advantages of Fibre Conduit

1. Low initial cost. Small percentage of breakage. Low freight cost per foot. Minimum space in duct line. Easy to handle. Low cost of finished duct.
2. Strength. Building excavations and short circuits have the minimum amount of damaging effect on fibre conduit.
3. Ease of cutting and connecting into a fibre duct; and ease of avoiding obstacles.
4. Ease of pulling cable in or out — minimum of damage to cable.
5. Ducts can be spread to enter manholes.
6. Damaged duct remains useable after severe cable failure.
7. Can be installed rapidly — an advantage in a busy street.
8. Will not warp, stick or grip cable, either from the effect of moisture or heat. Checks fire in case of arcing.



the sheath becomes seriously abraded or cut. Orangeburg Fibre Conduit joints prevent seepage of concrete.

Lack of protection to the cable in the duct is usually in the form of loose and non-waterproof joints which allow stray currents access to the cable.

Orangeburg Fibre Conduit when properly laid provides a duct in which all joints are watertight. Advantages of this are obvious where electrolysis is likely to prevail.

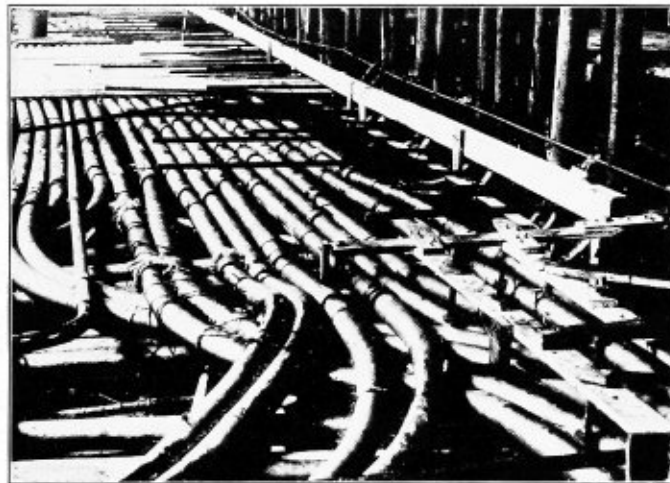

Installation of Fibre Conduit, Switchboard Floor, between lines "E" and "F", at United Electric Company, Springfield, Mass., Stone and Webster, Inc., Engineers and Contractors.

## Uses of Orangeburg Fibre Conduit

While the largest field of application for Orangeburg Fibre Conduit has been in electric service under-

ground systems, this product has also been applied satisfactorily in many special fields. It has been used as a conduit for electric conductors on electrified railways; it has been laid in concrete forms for conducting power house cable systems and for leaders from aerial lines to underground ducts. In addition to this, certain other special applications have been successfully tried but it is recommended that before Fibre Conduit be purchased for applications other than the above, the matter be taken up with the nearest Johns-Manville Branch.

## Protection of Cables

It is a recognized fact that about 90 per cent of all underground cable trouble is directly traceable to some injury to the lead casing of the cable, which takes place when the cable is being drawn into the duct; or to lack of protection which should be afforded to the cable after being placed in the conduit. The injuries to the cable while being drawn in are usually caused by burrs or blisters on the interior of the conduit, or to nipples of concrete that have seeped through the joints, formed and hardened on the bottom of the duct. In drawing the cable over these defects

## Approved by the Underwriters

The Underwriters' Laboratories, Inc., have approved Orangeburg Fibre Conduit for use in electrical generating and substations when laid in concrete.



## Price List—Schedule "A" Covering Standard Material

Prices F. O. B. Factory

Subject to Change Without Notice

AN EXTRA CHARGE WILL BE MADE FOR BENDS OF SPECIAL DEGREE OR RADIUS, FOR CUTTING TO SPECIAL LENGTH, FURNISHING MATERIAL TO SKETCH AND MATERIAL CUT TO WASTE

FIBRE CONDUIT	Inside Diameter, Inches	Price per Foot	Standard Crate contains, Feet	Approximate Gross Weight Standard Crate, Pounds	Approximate No. of Feet Minimum Carload 30,000 Lbs.	Maximum No. of Feet in 36 Ft. Car	Approximate Gross Weight Maximum Quantity 36 Ft. Car, Lbs.	Approximate Net Weight per Foot, Pounds
Socket Joint	2	\$0.10	200	270	33000	35000	31800	0.90
	2½	.11	200	320	27000	30000	33250	1.10
	3	.12	150	285	22800	25000	32800	1.30
	3½	.13	125	290	19800	21000	31800	1.50
	4	.15	100	280	16000	16500	30800	1.85
	4½	.19	100	330	13200	13300	30250	2.25
Harrington Joint Coupling Included with Each Length	2	\$0.13	200	295	31300	33000	31600	0.95
	2½	.14	200	355	24750	27000	32700	1.20
	3	.15	150	320	21250	23000	32500	1.40
	3½	.16	125	320	18000	20000	33300	1.65
	4	.18	100	320	14850	16000	32300	2.00
	4½	.23	100	380	12000	12000	30000	2.50

BENDS AND FITTINGS	Inside Diameter, Inches	Standard Bends, Each	Standard Crate of Bends contains Pieces	Approximate Gross Weight Standard Crate Bends, Pounds	Radius, Standard 45° & 90° Bends	Radius, Standard "S" Bends (20" Offset)	45° & 90° Elbows, Each	Extra Couplings Each
Socket Joint	2	\$1.75	25	255	18"-24"-36"	36"	\$2.15	
	2½	1.80	25	295	24"-36"	36"	2.15	
	3	1.85	20	280	36"	36"	2.20	
	3½	2.00	15	295	36"	36"	2.20	
	4	2.25	12	295	36"	36"	2.25	
	4½	3.25	9	250	36"	36"	3.00	
Harrington Joint Coupling Included with Each Bend or Fitting	2	\$1.90	25	265	18"-24"-36"	36"	\$2.25	\$0.10
	2½	2.00	25	310	24"-36"	36"	2.25	.11
	3	2.10	20	290	36"	36"	2.35	.12
	3½	2.30	15	310	36"	36"	2.35	.14
	4	2.60	12	305	36"	36"	2.45	.16
	4½	3.65	9	260	36"	36"	3.25	.20



SOCKET JOINT TYPE



HARRINGTON JOINT TYPE



## A Few Standard Bends



45° Bend—5' Long, 36" Radius—Socket Joint



"S" Type Bend—Socket Joint



90° Bend—5' Long, 36" Radius—Socket Joint



90° Bend—5' Long, 18" Radius—Socket Joint

## Elbows

Dimensions below are in inches and only approximate:

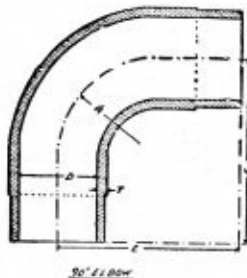

90° ELBOW

		90° ELBOW						45° ELBOW					
Both Types of Joint	D	2	2½	3	3½	4	4½	2	2½	3	3½	4	4½
	R	2½	2½	3	3	3½	4½	2½	2½	3	3	3½	4½
	E	6	6½	6½	7	7½	8						
	G							8½	9	9	9½	10½	12
Socket Joint	T	¼	¼	¼	¼	¼	⅝	¼	¼	¼	¼	¼	⅝
Harrington Joint	T	¼	¼	¼	¼	¼	⅝	¼	¼	¼	¼	¼	⅝

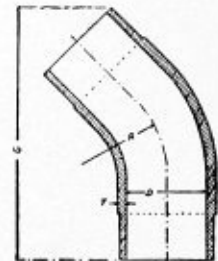

45° ELBOW

## Trade Customs

The right is reserved to ship from any of our plants. Sales subject to strikes, accidents or causes beyond our control.

Every piece of conduit is carefully inspected, but as it is impossible always to detect imperfections, the only guarantee that is given by us is to replace such goods as prove defective or allow credit for such goods at our option. Under no circumstances are we responsible for any damages beyond the price of the goods. No charge for labor or expense will be allowed. If the goods are defective, the measure of damages is the price of the defective pieces.

No material will be taken back and credited or replaced unless arrangements for such return have previously been made.

The carriers are responsible for the goods lost or

damaged in transit, therefore, as required in Rule 3 of Uniform Bill of Lading, in case of loss or damages en route, consignee must immediately notify the railroad agent at destination in writing in order to substantiate formal claim when presented.

Claims for shortage or deductions or erroneous charges must be promptly presented with full details or will not be allowed.

Special goods made to specification, where buyer is to inspect, must be inspected and accepted before shipment is made. After shipment is made, our responsibility ceases.

Requests for cancellation of orders calling for odd sizes or cut lengths, will not be considered if the manufacture of the material has been commenced when the request reaches the mill.





## The Orangeburg System of Underfloor Duct

(Pat. App. For)

JOHNS-MANVILLE INC., Sole Selling Agents

*A flexible system of distribution for service wires through ducts  
integral with the concrete floor*

**O**RANGEBURG underfloor duct system molds a network of tunnels for wires in the concrete floors of modern firesafe buildings which by such inclusion become an integral part of the structure.

The specification of this system obviates for all time mutilation of walls and floors; reduces to practically the bare cost of the wire itself the expense of additional electrical facilities or the rearrangement of old; removes the hazard of exposed wires, their unsightliness and the failure of the apparatus they serve, through their liability to interference and damage; and makes available for electric service every possible location at which apparatus or equipment may be wanted.

*Description:* The system consists of fibre ducts laid in the concrete of the floor in parallel lines sufficiently close one to the other that, wherever electrical machinery or apparatus may be placed, it will be over one of such lines. At convenient distances and at right angles are constructed header lines of the same duct, connected to these distributing lines and extended to the floor wiring centres. To the duct, access is had through an insert or outlet fitting placed through the finished floor and floor covering. Such outlets are only established as needed and if subsequently abandoned are closed in a simple manner, being, however, immediately available if wanted again.



Showing installation of Orangeburg System of Underfloor Duct in a floor of over 3" fill. Note "pad" or "bench" provided under duct and inconspicuous floor outlet.

**Duct:** Is the well known Orangeburg Fibre Conduit which through a quarter of a century has come to be the standard of subway construction for almost the entire electric light and power and electric railway industries. Confidence in its durability is assured by this record as its placement in floors (imbedded in concrete) is identical with its treatment in subway construction.



**Junction Boxes:** Of cast iron with brass tops and covers; strong and rugged; will withstand rust and corrosion equally with the building frame, and a load weight equal to the floor in which they are imbedded.

**Outlet Fittings:** Of cast brass of adequate design to withstand the compression in the top of floor slab in which they are placed.

**Water Exclusion:** Both junction boxes and outlet fittings are provided with durable gaskets making certain watertight joints at the floor line.

## Design

The Orangeburg system distinctly merits consideration from this point as it entirely eliminates guesswork in planning.

In systems previously used it has been necessary to install duct, outlet fixtures and wire previous to the occupation of the building. Further, in guessing as to

where service might be required at least twice as many outlets have been installed as were finally used.

In the Orangeburg system no outlets and no wire are installed until service is required and then only for the necessary requirements. Subsequent additions are as cheaply made as would have been the case had they been included in the original installation.

Two systems are offered: a double duct for heavy duty and a single duct for lesser requirements.

In the double duct system, two ducts are run side by side at the agreed spacing between the parallels: one duct for electric light and power wires, one duct for signal and communication wires.

In the single duct system all wiring is carried in one duct.

It is recommended that the parallels of the system be spaced from 5 to 6 feet apart, the first and last parallels from 2½ to 3 feet from the adjacent wall.

Headers should be spaced solely on a basis of estimated wire density, as wire can be fished to any distance met with in the floor areas of modern buildings.

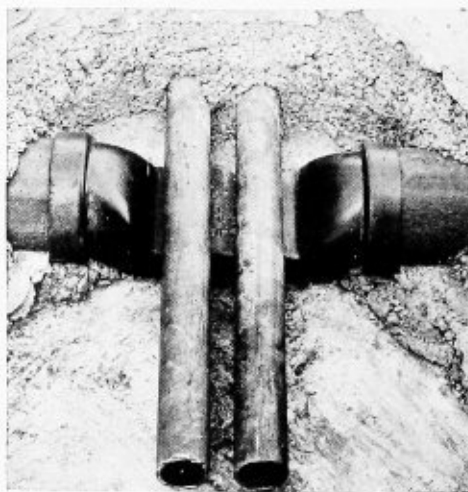

Installation showing crossunder fitting used when piping crosses the Orangeburg System of Underfloor Duct installation.



Standard size ducts used in the Orangeburg Under-floor Duct System are 4½" wide and 2¼" high over all and have been installed with entire satisfaction in buildings with floor fills of only 3". However, in most office buildings a fill of 4½" to 6" is generally provided.

Where the fill is greater than 3½" a concrete "pad" or "bench" should be provided so that when the ducts are installed on top of the pad the top of the duct will be about 1" or 1¼" from the finished floor surface. (See illustration on page 214.) This facilitates the installation of fittings and also raises the ducts above the floor slab so that other pipes can cross under the ducts by cutting through the pads.

Where a fill of only 3" or 3½" is provided any pipes which must cross the path of the ducts should preferably be cast in the concrete floor construction, or installed on

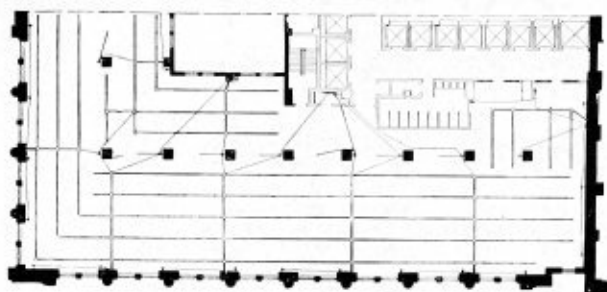

A typical floor plan of duct layout in the American Telephone & Telegraph Company's office building in New York City; 22 stories fitted with Orangeburg Underfloor Duct; complete installation.

the ceiling below.

A reasonable number can be accommodated by a special cast iron cross-under fitting which is installed in the duct line and offsets the line down about 2½", leaving a space 4½" wide and the entire height of the fill through

which pipes may be run as shown on page 214.

## Finish

In designing the fittings and duct full consideration has been given to both utility and appearance. The finished floor is neat in appearance and in satisfying contrast to the results obtained with other methods of interior wire distribution.



For details and specifications of the Orangeburg System apply to the nearest Johns-Manville branch or write for pamphlet E-30.

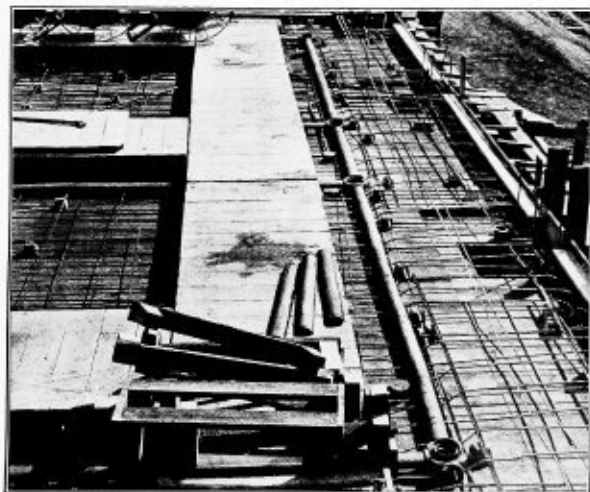

### SYSTEM IN REINFORCED CONCRETE

Closed-bottom Duct installed in Office Building, Long Island Railroad Co., Morris Park, N. Y.; Hatzel & Buehler, Inc., Elec. Contractors.

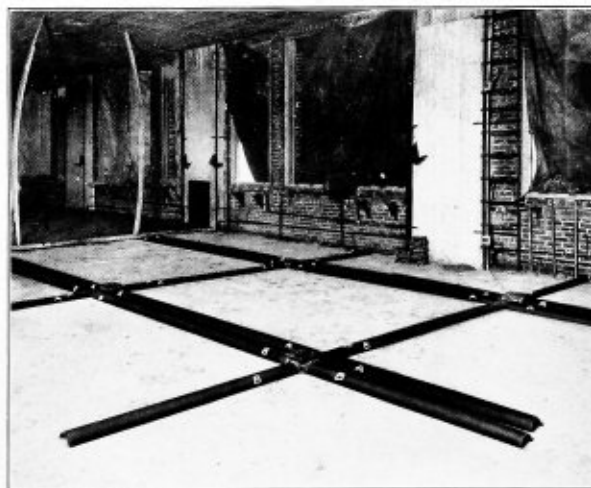

### SYSTEM IN FLOOR FILL

Installation in Western Electric Warehouse Building, N. Y. C.; double grid layout; J. P. Hall-Smith Co., Electrical Contractors.

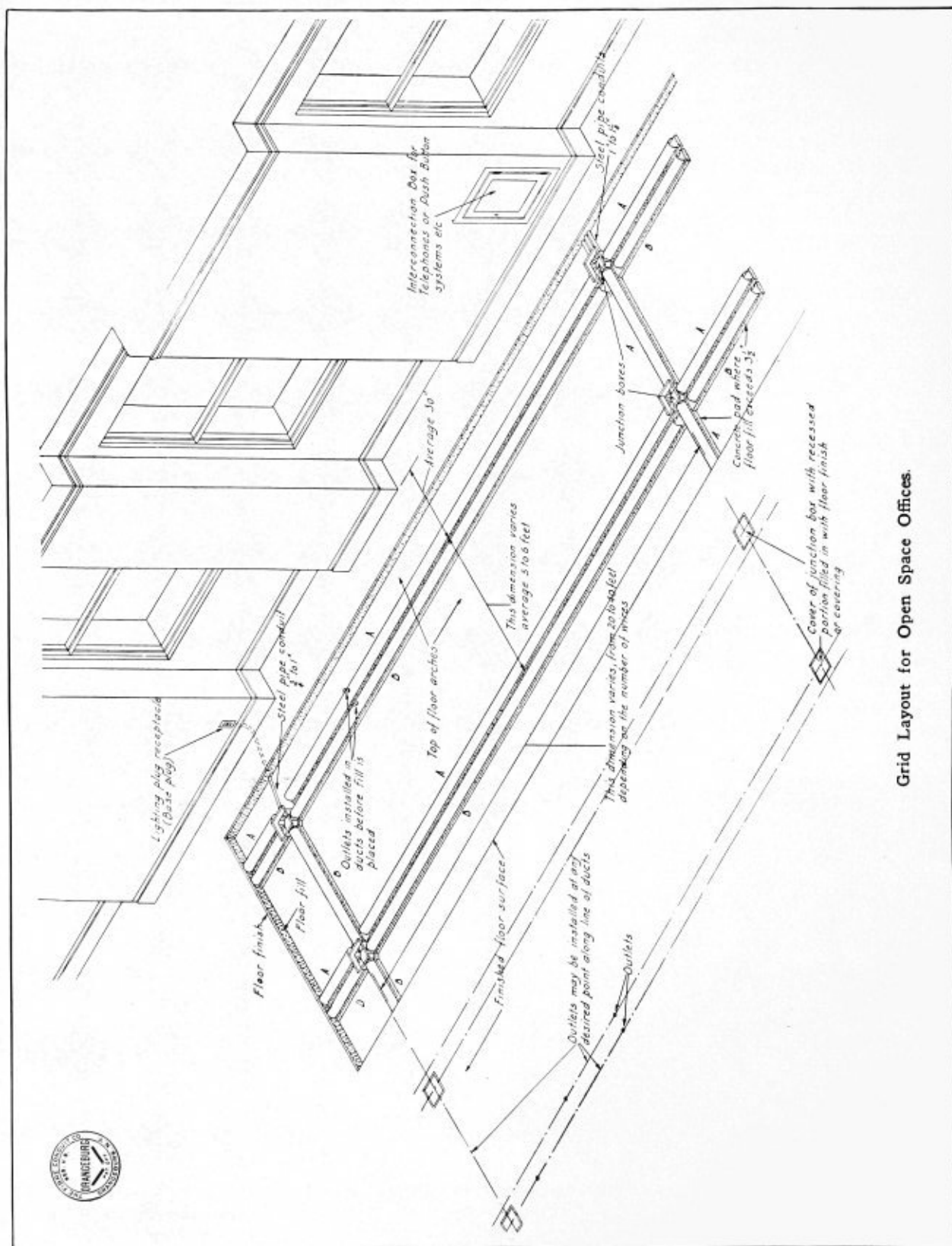

Grid Layout for Open Space Offices.









## Johns-Manville Friction Tapes



Careful manufacture of selected materials assures the highest quality in Johns-Manville Friction Tapes. They are better, more satisfactory and more durable in every way.

**J**OHNS-MANVILLE Friction Tapes are made of strong, closely woven fabric, heavily impregnated with a specially treated compound. They have remarkable adhesive properties and long life; are not affected by heat, cold or moisture; do not dry out with age; contain nothing to corrode wires; are free from pin-holes, lumps and thin spots and have exceptional insulating efficiency, due to the heavy and even saturation. They contain the maximum yardage per pound.

Johns-Manville Friction Tapes are three-fourths of an inch wide and are put up in standard 4-ounce and 8-ounce rolls, wrapped in tin-foil and packed in strong Manila paper cartons.

Johns-Manville Friction Tapes are standard with many of the largest steam and electric railroads in the United States. These are guaranteed tapes and with the exception of Johns-Manville Armature Tape will be replaced if found defective within one year from date of manufacture.

**Jomanco**—Gray in color, is the highest grade of friction tape on the market, and is recommended for permanent un-

derground, subway, mines, railway signal, sign, wireless telegraph systems and general out-door work, where the highest class of insulated joint is required. It is preferred by manufacturers of high-grade electrical machinery because of its ability to withstand high voltages. Used for all purposes under the most exacting conditions, it has never been known to fail.

**Johns-Manville No. 3 Tape**—A popular material for taping motor leads, switchboards and inside wiring where a good insulation is required. Strong in friction, possesses high heat-retarding qualities and dielectric strength.

**Johns-Manville No. 5 Friction Tape**—A good grade for standard electrical work and other miscellaneous and domestic uses; free from surface defects. Shows little or no deterioration for a year, if stored under proper conditions.

**Johns-Manville Armature Tape**—Made from thin, closely woven sheeting of highest quality, frictioned on one side only. Suitable for winding armatures, field coils, etc.



## Johns-Manville Rubber Splicing Compound

**M**ADE of Para rubber scientifically compounded so that it does not dry out. When applied it forms a homogeneous mass without the aid of heat, making watertight joints that last indefinitely.

Uniform in thickness throughout — no lumps or thin spots—and it has exceptional strength. Furnished in two brands, *Alpha* and *Brooklyn*,  $\frac{3}{4}$ " wide,

in 4-oz. and 8-oz. rolls, wrapped in tin-foil and packed in Manila paper cartons.

*Alpha Brand*— A splicing compound of the highest grade. It assures absolutely perfect joints, is impervious to moisture and stronger dielectrically and mechanically than the insulation of the wire itself. Will stand a test of 300 volts per mil.

*Brooklyn Brand* — A good splicing compound recommended for low voltage work.

## Johns-Manville Braided Asbestos Tubing

This tubing is largely used for insulating conductor wires of arc lamps and for covering electrical wires where superior fireproof protection is required.

It is absolutely fireproof and has been in constant use for many years during which it has never burned out, thereby causing a short circuit.

This material is extremely flexible; it can easily be made impervious to moisture, and has great durability.

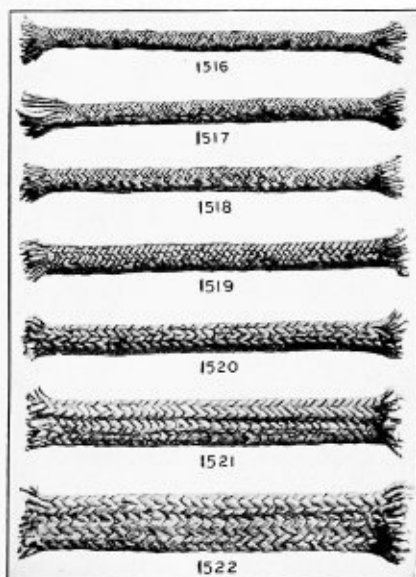

Some of the sizes in which Braided Asbestos Tubing is made.

No. of Tubing	To fit over Wire No.	Approximate Outside Diameter of Tubing	Approx. No. Lineal Ft. Per Pound	List Price. Per Pound
1516	17 B. & S.	$\frac{1}{8}$ "	175	\$4.00
1517	10 B. & S.	$\frac{5}{32}$ "	100	4.00
1518	8 B. & S.	$\frac{3}{16}$ "	85	4.00
1519	5 B. & S.	$\frac{1}{4}$ "	65	4.00
1520	4 B. & S.	$\frac{5}{16}$ "	50	3.00
1521	2 B. & S.	$\frac{3}{8}$ "	46	3.00
1522	0 B. & S.	$\frac{1}{2}$ "	22	3.00
1523		$\frac{5}{8}$ "	20	3.00
1524		$\frac{11}{16}$ "	16	3.00
1528		$\frac{3}{4}$ "	15	3.00
1529		$\frac{7}{8}$ "	13	3.00
1530		1"	12	3.00
1531		$1\frac{1}{4}$ "	10	3.00
1532		$1\frac{1}{2}$ "	9	3.00

Other diameters made to order; also any form of braiding desired.



## Johns-Manville Niagrite and Asbestoment Fireproof Cable Insulation

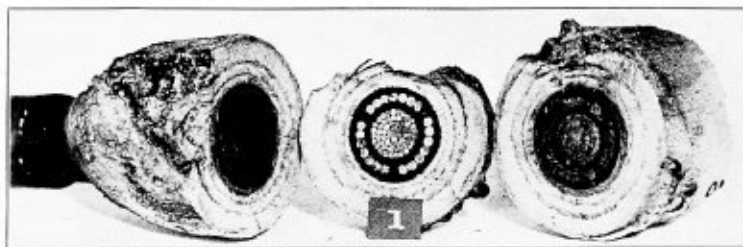

The illustration shows the slight effect of an electric arc at a voltage of from 90 to 110 and a current of from 400 to 2000 amperes, the electrodes placed  $\frac{1}{4}$ " below the test piece. It was intended to reproduce the destructive action which might be expected should an arc occur in the cable adjacent to the one on which the fireproofing was being tested. The

arc was sustained for a period of two minutes. It has been estimated that the temperature at the crater was from 3500° to 4000° F., the temperature falling off slightly at the higher voltage. During the test the thermo-couple showed the temperature rise in the tested cable to be within the bounds of safety by over 75° F.

**T**HE Johns-Manville Niagrite-Asbestoment Method of fireproofing cables has been developed to protect valuable cable equipment from the destructive action of an arc occurring in adjacent conductors. It is used wherever cables of high potential are exposed, particularly in manholes where splices are located, or where feeder cables are trained to the back of switchboards.

Its components are Johns-Manville Niagrite and Johns-Manville Asbestoment. Niagrite is an asbestos felted material backed with asbestos cloth, made in the form of a tape, in rolls 15 feet long and in all thicknesses from  $\frac{3}{32}$ " to  $\frac{1}{4}$ ". The best standard construction is a double layer of  $\frac{3}{16}$ " thickness. A roll of this tape is loosened and immersed for about twenty minutes in a solution of Johns-Manville Asbestoment. This is a special super-refractory cement, chemically neutral. Both these materials are free from ingredients which might corrode lead cable sheathing.

When the Niagrite tape has been thoroughly moistened with the cementing material, it is applied directly to the cable, being wound spirally with butted joints. The second layer should be applied with joints midway between joints of the initial layer, which makes for greater strength. An outer covering of Asbestoment, mixed

to a thick paste, is then applied by hand to a thickness of approximately  $\frac{1}{8}$ ". When dried, which takes approximately forty-eight hours under normal air conditions, the Asbestoment sets and becomes adamantine with age. Moisture or even immersion indefinitely has no effect on it. It may be applied 50% faster than any other form of cable fireproofing and will allow greater freedom in bending cables without cracking the fireproofing than any other known form of cable protection.

It has superior thermal conductivity so that heat within the cable is led away more rapidly than by muslin, paper or the rubber insulation nearest the copper conductors.

This Niagrite-Asbestoment combination has been tested under actual manhole conditions by some of the largest companies in the United States. (See test.)

This is assurance that this combination will prevent communication of burnouts where cables are exposed to an arc occurring in adjacent circuits. The resulting saving in valuable equipment and continuity of service is well worth the moderate cost of such an installation.

The nearest Johns-Manville office will be pleased to offer further suggestions as to cable equipment protection.





## Johns-Manville Fibroid Asbestos Paper Tape

**F**IBROID Asbestos Ribbon or Tape is a thin fireproof paper furnished in widths  $\frac{3}{8}$  of an inch and over in multiples of  $\frac{1}{16}$  of an inch and in thicknesses from .006 of an inch to .035 of an inch. Widths up to 36 inches are made specially to order.

It is put up in firm coils about 7 inches in diameter, 1 inch hole, cut with smooth edges. A roll 1 inch wide weighs about 1 lb. Approximate yardages in these 7 inch rolls are:

.006" thick.....	180 yds.
.010" thick.....	100 yds.
.015" thick.....	80 yds.
.020" thick.....	60 yds.

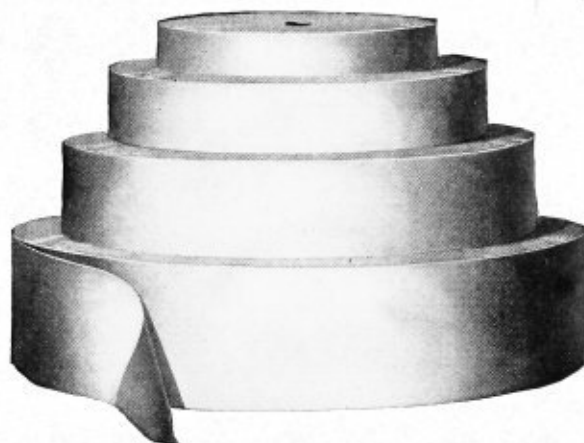

This tape is made from specially selected asbestos fibres and is used for wrapping magnet and armature wires.

LIST PRICES PER POUND

Thickness	Width	More than 100 lbs.	25 lbs. to 100 lbs.	Less than 25 lbs.
.015" to .035"	$\frac{3}{8}$ ".....	\$0.48	\$0.68	\$0.88
	$\frac{1}{2}$ " (or more).....	.28	.48	.68
.01" to .014"	$\frac{3}{8}$ ".....	.68	.88	1.08
	$\frac{1}{2}$ " (or more).....	.48	.68	.88
.006" to .01"	$\frac{3}{8}$ " (cut from special long fibre paper).....	1.12	1.32	1.52
	$\frac{1}{2}$ " (or more) (cut from special long fibre paper).....	.92	1.12	1.32

## Johns-Manville Armature Asbestos Paper Tape

**A**RMATURO Asbestos Paper Tape has been developed to meet the demand for a tape stronger mechanically than Fibroid Asbestos Paper Tape. Armature is made of two thicknesses of Fibroid Tape run up on each side of a cotton mesh without filler or sizing. The asbestos insures electrical and heat resisting qualities, while the cotton mesh gives

mechanical strength. Such reinforcing is particularly desirable when the tape is applied by winding machine.

Material as furnished is commercially pure.

Thickness	Width	Weight per roll
.015	$\frac{1}{2}$ "	$\frac{1}{2}$ lb.
.015	$\frac{3}{4}$ "	$\frac{3}{4}$ lb.
.015	1"	1 lb.

Prices on application.



# Johns-Manville Asbestos Listing

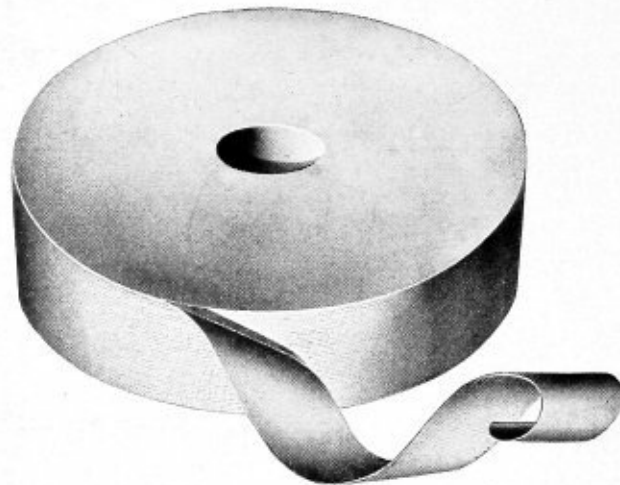

Serves many purposes where a thin, fire-proof insulation is needed to separate wires.

**J**OHNS-MANVILLE Asbestos Listing is a fireproof, flexible woven tape, suitable for wrapping all forms of electrical wires. It can be furnished pure or commercially pure.

Asbestos listing is made in widths from

$\frac{1}{2}$ " up and in thicknesses from .025" to  $\frac{1}{16}$ ". It can be furnished pure or commercially pure.

It can also be furnished wire-inserted in the  $\frac{1}{16}$ " thickness, if desired.

LIST PRICES AND YARDAGES PER POUND  
(Commercially Pure)

Width, Inches	No. 1091 $\frac{1}{16}$ " Thick		No. 1091 $\frac{1}{8}$ " Thick with Wire Insertion		No. 1073 $\frac{1}{32}$ " Thick		No. 1064 .025" Thick		No. 1082 $\frac{3}{64}$ " Thick	
	Per Pound		Per Pound		Per Pound		Per Pound		Per Pound	
	Yards	List Price	Yards	List Price	Yards	List Price	Yards	List Price	Yards	List Price
$\frac{1}{2}$	86	\$4.80	68	\$4.40	122	\$6.40	166	\$7.20	128	\$5.20
$\frac{5}{8}$	69	4.80	54	4.40	98	6.40	133	7.20	102	5.20
$\frac{3}{4}$	57	4.80	45	4.40	81	6.40	110	7.20	85	5.20
$\frac{7}{8}$	49	4.80	39	4.40	70	6.40	95	7.20	73	5.20
1	42	4.20	34	3.80	57	6.00	80	6.80	64	4.60
$1\frac{1}{4}$	34	4.20	27	3.80	49	6.00	66	6.80	51	4.60
$1\frac{1}{2}$	28	3.80	22	3.40	40	5.60	55	6.40	42	4.20
$1\frac{3}{4}$	24	3.80	19	3.40	35	5.60	47	6.40	36	4.20
2	21	3.20	17	2.80	28	5.20	41	6.00	32	3.60
$2\frac{1}{4}$	19	3.20	15	2.80	27	5.20	36	6.00	28	3.60
$2\frac{1}{2}$	17	3.20	13	2.80	24	5.20	33	6.00	25	3.60
3	14	3.20	11	2.80	19	5.20	27	6.00	21	3.60

Prices on pure asbestos listing furnished on application.



# Johns-Manville Third-Rail Covering



Special covering for the bonded fish plate joints.



Straight section for rail covering.

(As used by Philadelphia Rapid Transit Co.)

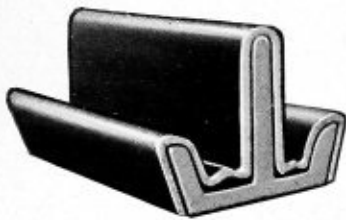

Covering of the T rail in the conduit of one of the street railways of New York City.



Wilgus Under-running third-rail covered with indurated fibre covering.

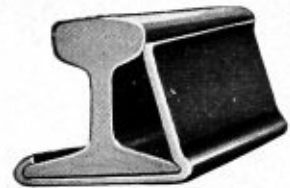

Transmission rail of the Elevated and the New York Subway. The exposed parts covered by indurated fibre material.

**F**OR many years we have supplied a weatherproof covering made of fibre and impregnated with a high quality of asphalt, for enclosing the feed rail of electric, street, mine and industrial railways.

Recent specifications have called for insulation to cover the sides and top of power rail, the contact being from the under side. To take care of the joints between rail lengths, enlarged sections have been developed which allow sufficient room to cover the fish plates, bolts and hangers, as shown above, but material can be furnished for practically any type of installation.

All inquiries sent in should include complete information as to use and service, in-

cluding the maker's name, section number and full size sketch of the rail, together with quantities and delivery desired. Present factory equipment will produce several of the more popular types, but where special material is required, a nominal preliminary charge may be made.

Johns-Manville Third Rail Insulation is the most modern protection so far developed; it has ample dielectric strength; provides a complete cover, if desired; will effect large savings through protecting power rails from ice coating in the northern latitudes; presents a most pleasing and ornamental appearance and, unlike wood covering, will withstand the elements indefinitely.



## Johns-Manville Electrobestos

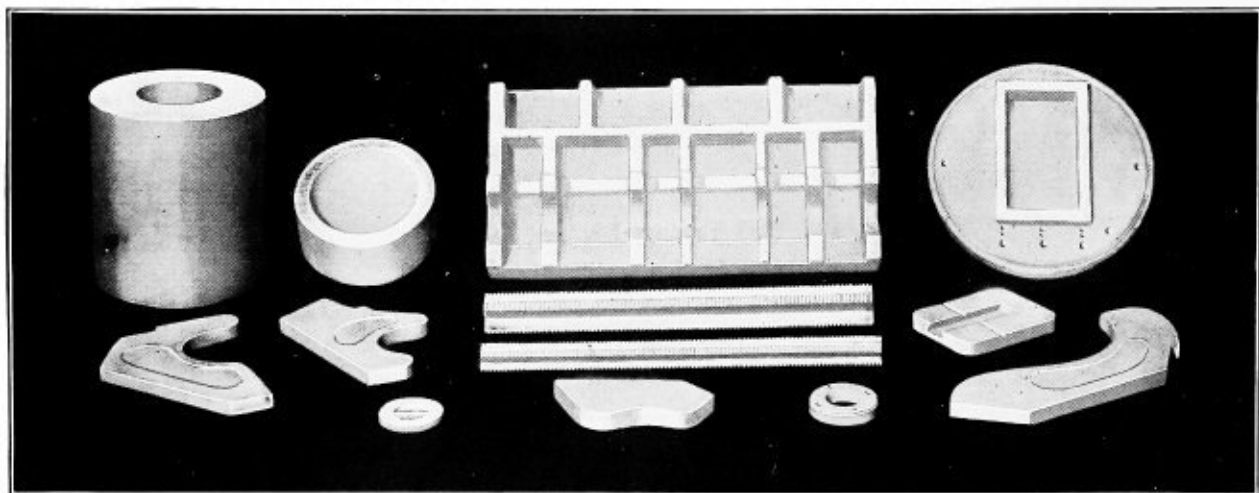

Heat proof cores, arc deflectors, apparatus bases moulded of Electrobestos give greater security at less expense. Electrobestos is chemically inert, of high dielectric and mechanical strength and heat-resisting.

**F**OR conditions requiring moulded pieces to stand high temperatures and where a moderate dielectric strength is necessary, we offer Johns-Manville Electrobestos, a compound made of high grade asbestos fibre, high temperature clays and a liquid binder, shaped cold under very high pressure and heat treated to solidify. This material is shaped in moulds of cast iron and hardened steel so that a moderate preliminary charge is made in each instance to cover mould expense. This charge is necessarily higher on complex moulds than on simple moulds.

Electrobestos has been successfully used where exposed to a temperature of 1600° F., although where other service is required of the pieces than resistance to heat, the figure of 1200° F. is a conservative estimate of its limit. It has considerable mechanical strength depending,

of course, on the shape of the piece, and a moderate dielectric strength. It should not be used under conditions involving vapor or moisture.

Its principal uses have been for arc chutes and deflectors in railway controllers, bushings of various sorts, cable shields, rods and tubes, resistance cores, soldering blocks, boiler plugs, electrical furnace parts, etc.

Due to the method of manufacturing, lateral holes and recesses are impracticable and walls should generally be not less than  $\frac{1}{4}$ ". Spiral threads or grooves unless very large, and threaded holes are also impracticable.

For quotation, sample, model or drawing should be submitted together with allowable tolerances and monthly or daily production necessary; also total quantity on which quotation is desired.



# Johns-Manville Asbestos Clothing, Textiles and Other Products

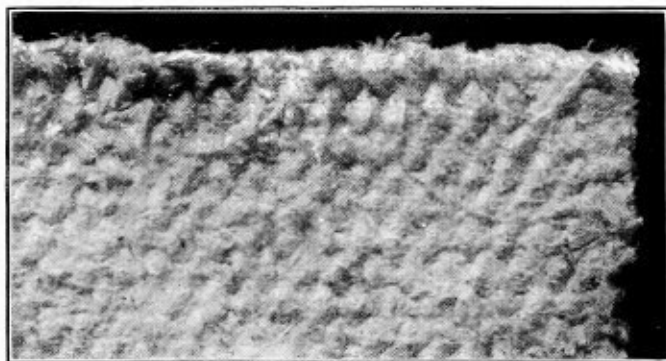



## Johns-Manville Asbestos Clothing

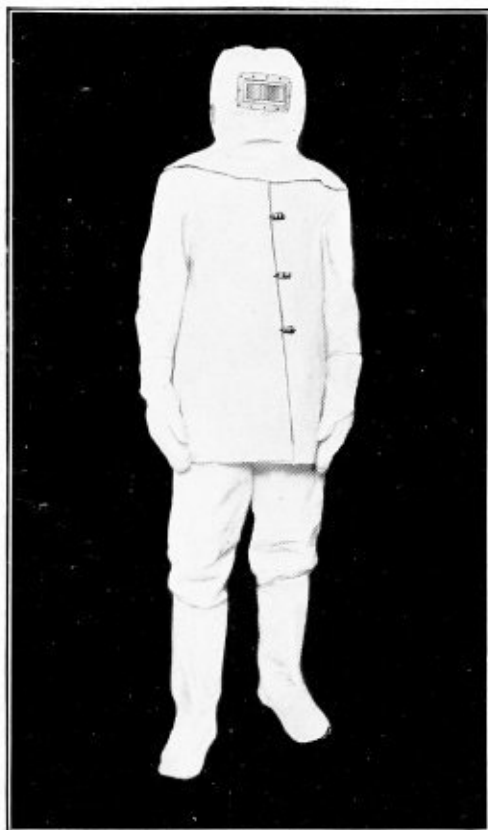

**T**HE pictures and descriptions given here of some of the standard items of asbestos clothing which we manufacture are but suggestions.

We have selected the types which have been found most serviceable under rigorous working conditions but there are many special models which we make but do not show here, that are particularly suitable for certain industries. We are glad to make any form of asbestos garment to specifications.

### ASBESTOS SUIT

The complete suit demonstrates the protection which can be afforded the workman without interfering with his activities.

Combined with jumper and overalls, the asbestos helmet offers complete protection with minimum binding. It is free-fitting and in no way impedes the workman.

For workers on oxy-acetylene or electric arc welding, splashing metal, heat and glare make it an essential part of their equipment. Open hearth men should have cobalt blue lenses to enable them to watch the metal. Welders' lenses should be dark green or several laminations of blue and red glass.

Johns-Manville will make helmets such as this to your specifications, setting mica or any color plain or laminated glass in the free vision window. This helmet buckles to the shoulders of the jumper. Another style has a cape to cover the shoulders. A good feature of this helmet is the ventilators at the sides.

This type of jumper is much used in steel mill service and in other places where workmen are exposed to molten metals, sparks, or flames. Substantially constructed of asbestos cloth, lined throughout with heavy duck, and has blind seams and riveted clasps.

Only the strongest and most serviceable asbestos cloth is used in our asbestos mittens. They provide efficient protection for those compelled to handle heated objects. Made to specifications in any desired length with plain or reinforced palm and thumb. Standard lengths 12, 14 and 16 inches.

Asbestos overalls are usually used in combination with the jumper. Made from heavy, durable asbestos cloth. Have double-sewn, reinforced seams; one seam in the leg. Adjustable leather suspender straps fastened with sliding wire buckles. Lined with heavy duck.



## ASBESTOS LEGGINGS

The asbestos leggings are made of durable asbestos cloth with or without lining, in any length desired and with or without foot-protecting flap. Adjustable to any size leg. Held by spring pressure, which enables the workman to snap them off instantly. The rear flap, which goes inside, fills the gap in the back thus completely covering the leg.

Where workmen are liable to injury from molten metal splashes, the complete protection which asbestos affords is inestimable, while the quick-detachable feature in the spring-clip fastening prevents delay in removing the legging and thus prevents severe burns.

Standard lengths 14, 16, 18 and 20 inches.



ASBESTOS GAITERS

Made of heavy long-fibre asbestos cloth, closely woven. The adequate foot-guarding flap has an arch-strap to keep it from slipping out of place. Buckles are serviceable and non-corroding; the straps real leather, for durability.

Workers in acid mills and chemical plants are afforded indisputable protection to person and clothing—for asbestos resists commercial solvents and corrosives.

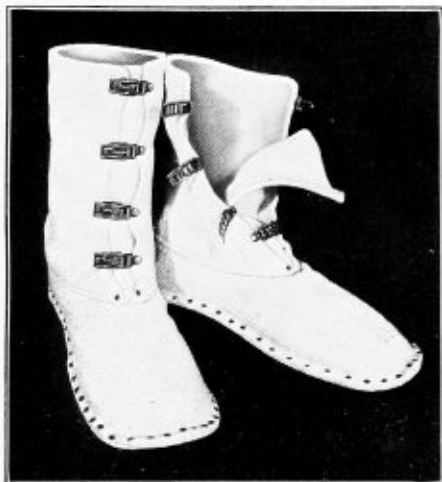

ASBESTOS SHOES

We are prepared to furnish to your specifications asbestos boots and shoes. High overshoes such as those illustrated are used in foundries and similar places.

These are made of extra heavy asbestos cloth and reach nearly to the knees. They fasten with easily snapped buckles. They have asbestos soles reinforced with steel rivets. The tongue is thick and of liberal width for full protection.



ASBESTOS GLOVES

Practically essential to all workmen handling hot tools or materials. Standard lengths 12, 14 and 16 inches. Plain or reinforced palm and thumb. Fleece lining standard. Made large to enable them to be quickly thrown from the hand.



**ASBESTOS ONE-FINGER MITTENS**

Similar to our regular mittens, except one finger is left free. Standard lengths 12, 14 and 16 inches. Plain or reinforced palm and thumb. Fleece lining standard.



**ASBESTOS CAP**

Asbestos cap, peak style, square crown, of particular use to workmen in plants where the hair and upper face need protection.

This style of cap is but one of many we have made for various occupations. Whatever the requirements of your plant or process, we can provide dependable protection. Only high grade asbestos cloth is used for the exposed portion. Caps are lined with duck if other material is not specified. Light in weight and comparatively cool.

We can make caps with capes to cover the back of the head and neck. Air ports or vents can be readily inserted, or the visor shape changed.

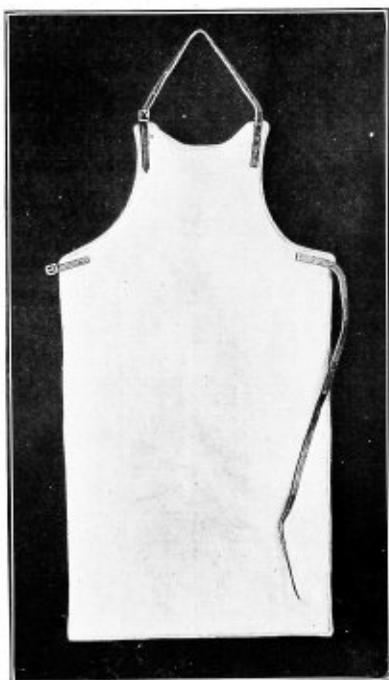

**ASBESTOS APRON**

For the laboratory or bench worker in chemicals or when hot materials or tools demand front protection only, asbestos aprons assure safety to person and clothing. Made to any shape or length. Durable leather neck and back straps with buckles. Lined with a good grade duck, unless otherwise specified.



**ASBESTOS ARM PROTECTORS**

Workers in chemicals will find asbestos arm protectors very useful when worn with our mittens or gloves. Made of tough, long wearing asbestos in lengths to protect arms to elbows or shoulders. Standard lengths 18, 20, 24 and 26 inches.





## Johns-Manville Asbestos Cloth

**J**OHNS-MANVILLE Asbestos Cloth is used in the manufacture of theatre curtains, portable motion picture booths, blankets, gloves, clothing, etc., to assure protection from fire.

On account of its chemical-resisting qualities, Johns-Manville Asbestos Cloth is also used extensively in plants where chemicals are manufactured or where chemicals are used in the manufacture of some other product. Filter pads and cloths, mats, etc., are some of the forms in which Asbestos Cloth is used in such places.

Packings, that must resist heat and certain chemicals, and brake band lining are made of Asbestos Cloth.

Uniformity in our Asbestos Cloth products is assured because of care taken in manufacture and the splendid modern equipment in the textile departments of our factories.

Quality as well as uniformity is found in every piece of Johns-Manville Asbestos Cloth because we own and control our own source of supply and, therefore, can select the kind and grade of asbestos fibre suitable for the service to which the cloth is to be subjected.

Following is a list and description of standard Johns-Manville Asbestos Cloths:

Style No.	Width	Approximate weight per square yard	Quality*
1067	36 inches	2 lbs. 8 ozs.	C. P. no wire
444	36 inches	2 lbs. 4 ozs.	C. P. no wire
M-710	36 inches	2 lbs. 1 oz.	C. P. no wire
912	36 inches	2 lbs. 6 ozs.	P. no wire
M-189	40 inches	2 lbs. 12 ozs.	C. P. wire inserted
M- 31	40 inches	2 lbs. 12 ozs.	C. P. wire inserted
M- 32	40 inches	2 lbs. 6 ozs.	C. P. wire inserted

\*NOTE:—

C. P. denotes cloth is commercially pure.

P. denotes cloth is absolutely pure asbestos.

Wire inserted cloth is woven of asbestos yarn with small brass wires used for reinforcing.

## Johns-Manville Asbestos Yarns

**J**OHNS-MANVILLE Asbestos Yarns spun from asbestos fibre are used extensively and for various purposes on account of their heat and chemical resisting qualities.

Johns-Manville, because of long experience, modern equipment and ownership of mines, is prepared to furnish yarns of high and uniform quality.

The standard Johns-Manville Asbestos Yarns listed below will answer for most conditions. If special yarns are required, samples or specifications should be submitted.

Style No.	Ply	Approximate number of yards per pound	Percent Cotton
1004	1	400	10%
1004	2	200	10%
1004	3	130	10%
1004	4	100	10%
1008	1	800	10%
1008	2	400	10%
1008	3	260	10%
1008	4	200	10%
1010	1	1,000	10%
1010	2	500	10%
1010	3	330	10%
1010	4	250	10%
1012	1	1,200	10%
1012	2	600	10%
1012	3	400	10%
1012	4	300	10%
1014	1	1,400	10%
1014	2	700	10%
1014	3	460	10%
1014	4	350	10%
504	1	400	5%
504	2	200	5%
504	3	130	5%
504	4	100	5%
508	1	800	5%
508	2	400	5%
508	3	260	5%
508	4	200	5%
510	1	1,000	5%
510	2	500	5%
510	3	330	5%
510	4	250	5%
512	1	1,200	5%
512	2	600	5%
512	3	400	5%
512	4	300	5%
514	1	1,400	5%
514	2	700	5%
514	3	460	5%
514	4	350	5%



## Johns-Manville Asbestos Wood Motion Picture Projection Booth

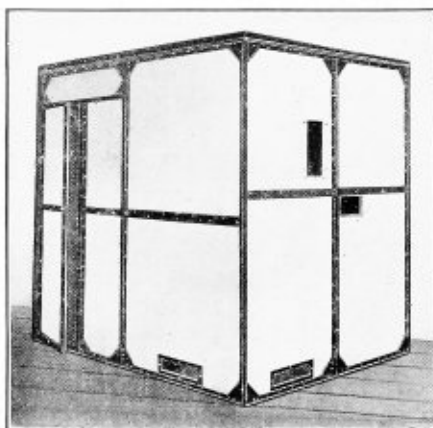

Johns-Manville Asbestos Wood Booth, Permanent Style

**J**OHNS-MANVILLE Asbestos Wood and Angle Iron Booths are fire-proof, shock-proof and, when pointed up with Johns-Manville Asbestos Cement, absolutely smoke tight. The Johns-Manville Booth prevents the noise and light of operation from interfering with perfect projection or detracting from the quality of the exhibition. Are so arranged that in case of fire, all openings are automatically closed, confining the fire within the booth. Can be painted or decorated to match any interior trim.

The permanent style of booth is made of asbestos wood sheets attached by bolts to structural steel framework. The asbestos wood is bolted on after the skeleton frame is set up, insulating the frame from electrical currents and making the booth fire-proof. Furnished in "knock-down" form and provided with a door and window shutters to close automatically in case of fire. A complete ventilating system, including galvanized iron pipe flues and an exhaust fan can also be furnished.

The semi-portable booth is made of asbestos wood sheets or panels, framed with angle irons. Walls and roof are made of

panels of asbestos wood framed with angle irons and are made interchangeable. They are plainly marked so that they can be easily put together by any carpenter without the necessity of fitting, filing or drilling. This booth can be put together or taken down in an hour or two and only about fifty bolts are required. The semi-portable booth can also be enlarged by the addition of standard panels.

The portable booth is asbestos cloth over iron pipe framework. Asbestos cloth is strong, light and well adapted to this purpose. It can be set up or taken down in a few minutes and packed into small space in fibre or wooden cases for shipment. The asbestos cloth covering is made in three pieces; the top, sides and flooring with overlapping flaps, so that the booth is practically smoke-tight. A special hinged trap, which provides a ventilating space is so arranged that it will automatically close in case of fire.

The Junior Booth is made of the same materials as the semi-portable booth—Asbestos Wood with steel frame—but requires less floor space.



## Johns-Manville Success Chemical Fire Extinguishers

Approved and labelled by the Underwriters' Laboratories, Inc.

### Automatic Type

Johns-Manville Success Fire Extinguisher is made of extra heavy, cold rolled, Lake Superior copper. Starts and stops simply by reversing the position of the extinguisher.



An effective fire-fighting apparatus that can be easily handled, operated and recharged. Throws a high pressure stream for distances up to 50 ft. Extinguishes benzine, naphtha, tar and other flames on which water has practically no effect. It is superior to others for the following reasons:

All joints are securely riveted and reinforced by heavy shoulders of solder.

Tested to a pressure of 350 lbs. to the square inch—four times the required strength.

Made with a standard size bottle and cast brass bottle holder, instead of the flimsy brass wire holder ordinarily used.

Also a unique bottle stopper which regulates the flow of sulphuric acid into the bicarbonate of soda thus generating the correct amount of gas at all times. This avoids explosion—which is possible in extinguishers where total quantity of both liquids is mixed at once.

The Johns-Manville Success Fire-Extinguisher meets every requirement of dependability and durability.

### Hand-Pumped Style (Non-Freezing)

The Johns-Manville Success Non-Freezing Fire Extinguisher will not freeze at any temperature above forty degrees below zero. It will afford unfailing protection from fire at all times, particularly when other fire extinguishers, as well as water pipes, would be frozen up and out of commission.

Easily portable and can be operated by anyone. A pliable rubber hose makes it possible to aim the stream in any direction without moving the extinguisher.

Throws a continuous stream fifty or sixty feet. Has a 2½ gallon capacity, sufficient for most incipient fires.

Tank is made of copper, protected by a double application of lead-tin alloy and a coating of "Insulite," an asphaltic base paint. Double acting pump is made of seamless brass tubing. Pump plunger made of a special alloy not affected by the solution.

Tested by the Underwriters' Laboratories, Inc., by being operated 73,000 strokes and remained in good working order.

To operate: withdraw the metal pin holding the pump handle which releases the pump and permits immediate use. Recharged by pouring solution through filler opening. No recharging necessary until contents have been discharged, as solution will not deteriorate.





## Johns-Manville Asbestos Lead Joint Runner

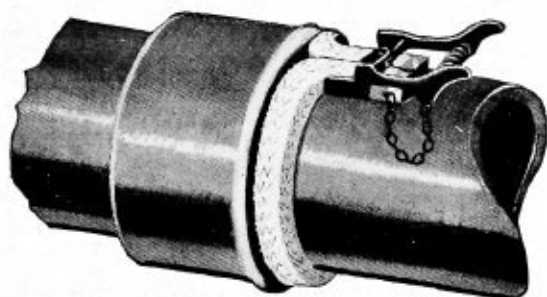

Runner equipped with spring clamp.

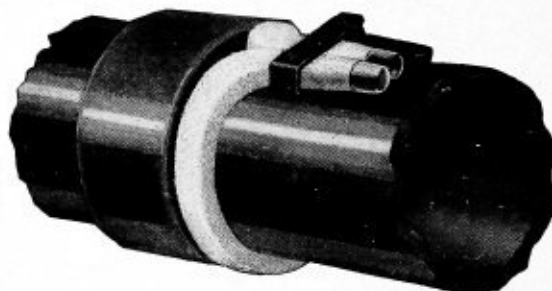

Another style, equipped with toggle clamp.

**F**OR making lead joints in cast-iron gas and water pipes, Johns-Manville Asbestos Lead Joint Runner is the most practical device on the market. It is composed of specially prepared asbestos rope, of square cross-section, having a ferrule on each end and provided with a clamping device for fastening in place on the pipe as shown in the above illustrations. The rope used is solid asbestos, containing no core of jute or other combustible material.

Owing to the shape of this device and its flexibility, it covers the pipe joint snugly, so that there is no leakage of lead nor any unnecessary lead left protruding from the joint to be chipped off afterwards.

Being made of asbestos, it will not char or burn from contact with molten metal. The ferrules are of such design that they cannot be pulled off. The clamp is of simple construction and practically indestructible.

### ASBESTOS RUNNERS FOR VARIOUS SIZES OF PIPE

No.	Material	Size	For Pipe Size, inches	List Price each
1	Rope	$\frac{3}{4}$ inch square	2, 3 and 4	\$2.15
2	Rope	$\frac{3}{4}$ inch square	4, 5 and 6	2.35
3	Rope	1 inch square	6, 8 and 10	4.15
4	Rope	1 inch square	10, 12 and 14	5.40
5	Rope	$1\frac{1}{4}$ inch square	16, 18 and 20	11.00
6	Rope	$1\frac{1}{4}$ inch square	24	12.25
7	Rope	$1\frac{1}{4}$ inch square	30	13.95
8	Rope	$1\frac{1}{4}$ inch square	36	15.75
9	Rope	$1\frac{1}{4}$ inch square	42	17.65
10	Rope	$1\frac{1}{4}$ inch square	48	18.80



# Johns-Manville Non-Burn Asbestos Brake Band Lining for Automobiles

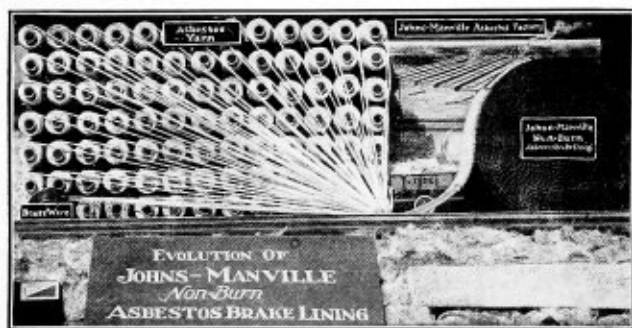



# Johns-Manville Non-Burn Asbestos Brake Band Lining



Woven



Folded and compressed

**F**ROM Johns-Manville mines, specially selected asbestos fibre goes to Johns-Manville factories, where the fibre is spun into a pliable, workable yarn, reinforced with brass wire twisted in each strand to give additional mechanical strength. It is next woven into one piece to the required width and thickness, after which it is impregnated with preserving and friction-increasing material.

Folded and compressed lining is made from woven asbestos cloth, the yarn employed being reinforced with brass wire which gives added mechanical strength. The cloth is then folded, cemented, compressed and vulcanized under tremendous pressure.

Thus, Non-Burn Asbestos Brake Lining, from mine to roll, is exclusively a Johns-Manville product, meeting at all times rigid requirements based on the experience of many years in the manufacture of asbestos frictional materials.

Johns-Manville Non-Burn Asbestos Brake Lining is most economical because it has maximum gripping power and highest resistance to heat and wear. The impregnating compound adds to the effi-

ency and durability of the lining. Made in two styles:

Woven, in thicknesses up to  $\frac{5}{16}$ ", as quoted below. ( $\frac{3}{8}$ " thickness made in folded and compressed only.) Folded and compressed, up to and including  $\frac{3}{8}$ " thick.

Johns-Manville Brake Lining and Clutch Facing Data Book showing sizes suitable for specific models of cars and trucks, sent on request.

## LIST PRICES PER LINEAR FOOT

Width, Inches	Thickness, Inches					
	$\frac{1}{8}$	$\frac{1}{4}$	$\frac{3}{8}$	$\frac{1}{2}$	$\frac{5}{8}$	$\frac{3}{4}$
1	\$0.40	\$0.45*	\$0.50	\$0.70	\$0.80	\$0.96
1 $\frac{1}{4}$	.50	.55*	.60*	.80	.94	1.16
1 $\frac{1}{2}$	.60	.65*	.70*	.90	1.11	1.35
1 $\frac{3}{4}$	.....	.70	.....	.....	.....	.....
1 $\frac{7}{8}$	.70	.75*	.80*	1.00*	1.26	1.54
2	.....	.80	.....	.....	.....	.....
2 $\frac{1}{4}$	.80	.85*	.90*	1.20*	1.41	1.73
2 $\frac{1}{2}$	.90	.95*	1.00*	1.30*	1.56	1.92
2 $\frac{3}{4}$	1.00	1.05*	1.10*	1.50*	1.72	2.12
3	1.10	1.15*	1.20*	1.60*	1.87	2.31
3 $\frac{1}{4}$	1.20	1.25*	1.30*	1.70*	2.02	2.50
3 $\frac{1}{2}$	1.25	1.35*	1.40*	1.80*	2.16	2.69
3 $\frac{3}{4}$	1.30	1.45*	1.50*	1.90*	2.21*	2.88
4	1.35	1.50	1.60*	2.05*	2.31*	3.08
4 $\frac{1}{4}$	1.40	1.55	1.70*	2.20*	2.50*	3.27
4 $\frac{1}{2}$	1.80	1.94	2.08	2.50*	2.92*	3.65
5	1.92	2.11	2.29	2.70*	3.22*	4.04
5 $\frac{1}{2}$	2.12	2.31	2.50	3.01*	3.52*	4.42
6	2.27	2.49	2.71	3.27*	3.82*	4.80

Stock sizes indicated by \*, all other sizes special. Standard rolls, all sizes, 50 feet.



## Johns-Manville Transmission Linings for Ford Cars



Each carton contains three pieces of proper length for Ford bands, complete with rivets.

**O**N Ford Cars the foot brake is located on the driving shaft just back of the engine and enclosed in the transmission case with the low-speed clutch and the reverse clutch. This case is filled with lubricating oil, and the lining of the foot brake is always saturated with oil, which sometimes heats up to 400° F.

Johns-Manville Brake Lining for Ford Cars is made in two types: Cotton and Asbestos; the first known as style F, and the second as style XX. Both meet the conditions obtaining in Ford cars and give excellent results.

Neither type contains wire, because it has been found that metallic particles coming from the wires, as they are worn off, get into the magneto and cause a short circuit.

Both Ford types are made of a densely woven, tough fabric of remarkable gripping power and durability, impregnated with a compound peculiarly adapted to the oily conditions obtaining in this car.

Furnished in 50-foot standard rolls; also in attractive cartons as illustrated, with necessary rivets for attaching.

### XX ASBESTOS (1 1/8" x 3/2")

Made identical with Johns-Manville Non-Burn Asbestos Woven Brake Lining except that no wire is used.

List price per carton.....\$2.00  
List price per foot..... .50

### XX ASBESTOS OVERSIZE (1 1/8" x 3/16")

For replacement where drums are worn.

List price per carton.....\$2.50  
List price per foot..... .55

### F COTTON

Manufactured from the best long fibre Sea Island Cotton; impregnated with an oil and heat-resisting compound. Contains no wire.

List price, per carton, \$1.50; rolls, per foot, \$.25

#### Approximate Weights, Lining Only

XX Asbestos	.....	5 1/2 lbs. per 50-ft. roll
" " Oversize	.....	5 3/4 lbs. per 50-ft. roll
" " Oversize	.....	3/4 lb. per carton
" " Oversize	.....	7/8 lb. per carton
F Cotton	.....	4 lbs. per 50-ft. roll
" " Oversize	.....	1/2 lb. per carton

#### Weights Packed for Shipment

XX Asbestos	5 50 ft. rolls, approx.....	32
" "	10 50-ft. rolls, approx.....	75
" "	10 cartons, approx.....	10
" "	25 cartons, approx.....	25
" "	100 cartons, approx.....	105
" "	Oversize, 5 50-ft. rolls, approx.....	33
" "	" " 10 50-ft. rolls, approx.....	85
" "	" " 10 cartons, approx.....	12
" "	" " 25 cartons, approx.....	28
" "	" " 100 cartons, approx.....	115



## Johns-Manville Asbestos Woven Clutch Facings



Woven clutch facings have been generally approved by many of the leading car manufacturers.

**J**OHNS-MANVILLE Asbestos Woven Clutch Facings are constructed to proper dimensions by special processes which insure smoothness of clutch engagement. The quality of the woven asbestos material prolongs the life of the facings under the most severe conditions.

Considerable research and development work indicate that for Borg & Beck and similar types of single disc clutches, it is necessary to use a facing with that degree of resiliency obtained in a woven fabric, which secures smoothness of clutch engagement without chattering or grabbing.

We can manufacture facings of any size, plain, or drilled and counterbored, for cone or disc clutches from woven, or, if

necessary, folded material, the latter being a specially built-up facing.

Johns-Manville Facings can be made formed and joined with metal staples or cut endless.

Write for Johns-Manville Brake Lining and Clutch Facing data book, listing all sizes required for specific makes of cars and trucks, and quoting prices of facings for popular automotive vehicles.

Johns-Manville Asbestos Woven Clutch Facings are suitable for all makes of cars and trucks. They can be furnished plain and also drilled and counterbored ready for riveting.

Packed in properly labeled *standard* cartons of twenty facings each.





## Johns-Manville Asbestos Friction Disc Clutch Facings



Standard carton of drilled and counterbored facings. Made in many sizes suitable for popular models of passenger cars and trucks.

**M**ADE from long-fibred asbestos closely interlocked to a homogeneous structure, combined with a heat-resisting bond and compressed into facings of uniform density, ground accurately to proper thickness.

Grinding the facing removes from its face a film of impregnating material which otherwise would have to be worn off in operation before the maximum efficiency of the clutch could be attained.

Compressing the facing insures the absence of high spots or a wavy surface, and enables us to produce a facing of uniform density with a perfectly flat surface.

The exceptional care and special processes used in the manufacture of these facings result in a product which may be used without the necessity of continual re-adjustment of clutches. As produced under our process, the facings possess a uniform co-efficient of friction and an exceptionally long life.

Johns-Manville Asbestos Friction

Clutch Facings are made of the best quality asbestos fibre, especially selected for this usage from our own mines, and are manufactured in one solid mass, in ring form or segments, as may be required.

The frictional contact surfaces dependably transmit the power for which the clutch was designed without excessive wear of the facing, and our special treatment of the material insures uniform clutch action at its maximum efficiency throughout the life of the facing.

Clutches equipped with Johns-Manville Asbestos Friction Clutch Facings engage easily and release without sticking.

Packed in standard cartons containing 20 rings each, properly labeled. All rings can be shipped plain or drilled and counterbored.

Write for Johns-Manville Brake Lining and Clutch Facing data book, listing all sizes required for specific makes of cars and trucks and quoting prices of facings for all popular automotive vehicles.



# Johns-Manville Automotive Service Sheet Packing

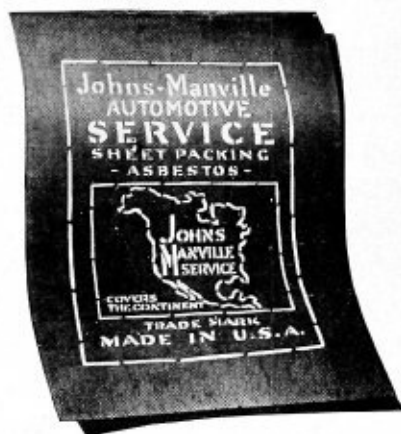

Johns-Manville Automotive Service Sheet Packing is very dense, strong and resilient. It assures tight joints and prevents leakage.

**T**HE thinner the packing, the better the service, because less area is exposed to pressure on a thin than on a thick gasket.

Service Sheet is designed for practically any flange service in the automotive industry.

*Recommended for intake and exhaust manifolds and cylinder heads.*

Made of asbestos fibre bonded with a special heat-resisting compound. Very resilient, strong and dense, and does not squeeze thinner when the joint is tightened, thereby preventing leakage.

Graphited one side only, thus when joints are broken, the gasket will stick to one surface and part from the other.

Scrap can be saved and used, as Service Sheet does not rapidly deteriorate with age.

Service Sheet is also supplied  $\frac{1}{32}$ " and  $\frac{1}{16}$ " thick, in sheets  $10\frac{1}{2}$ " x 54" long, packed in a special round carton, measuring  $11\frac{3}{8}$ " high, by  $3\frac{1}{4}$ " diameter, properly labeled.

This size is sufficient for practically any gasket, and protects sheet from bending and breaking after small pieces have been cut off.



A handy shelf package easy to handle in stock and it saves waste for the user.

Thickness, inches	Weight, lbs.	List Price per Carton
$\frac{1}{32}$	1 $\frac{1}{4}$	\$1.70
$\frac{1}{16}$	2 $\frac{3}{8}$	3.40

Size of Sheet	Thick-ness	Approx. Weight	List Price Each	Size of Sheet	Thick-ness	Approx. Weight	List Price Each
54" x 63"	$\frac{1}{32}$ "	7 lbs.	\$9.10	"AUTOMOTIVE SPECIAL" . . . . . 27" x 31 $\frac{1}{2}$ " . . . . .	$\frac{1}{32}$ "	1 $\frac{3}{4}$ lbs.	\$2.30
	$\frac{1}{16}$ "	14 lbs.	18.20		$\frac{1}{16}$ "	3 $\frac{1}{2}$ lbs.	4.60



## Johns-Manville Automotive Seigelite Sheet Packing

**A** FIBROUS material that resists the action of water, oils and gasoline because it contains no rubber substitutes soluble in oil or gasoline. It has an extremely high tensile strength, and when immersed in water or other fluids becomes extremely tough, resembling rawhide.

Seigelite is very desirable for gaskets on water manifolds, crank or transmission cases, differential housings, carburetors, clutch and timing gear covers.

*Not to be used for cylinder heads or exhaust manifolds.*

It is tougher than wrapping paper or cardboard, and cheaper than rubber.



A tough, durable sheet packing for water, oil, gasoline, etc.

### FURNISHED AS FOLLOWS:

Thick- nesses	Sizes of Rolls	List Price per Sq. Yd.	List Price per Lin. Yd.
1/64"	25 or 50 yds. by 48"	\$1.05	\$1.40
1/32"	25 or 50 yds. by 48"	1.90	2.53
1/16"	25 or 50 yds. by 48"	4.50	6.00

### SPECIAL FOR AUTOMOTIVE EQUIPMENT

Furnished in sheets 24" by 36" (25 sheets per crate)

Thick- nesses	Weight per Crate	List Price per Sheet
1/64"	33 lbs. gross	\$1.00
1/32"	46 lbs. gross	1.65
1/16"	73 lbs. gross	3.40

## Johns-Manville Automotive Tape

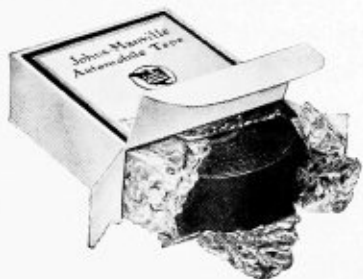

The shape and attractiveness of Johns-Manville Auto Tape cartons make them very desirable for shelf display.

**J**OHNS-MANVILLE Auto Tape will successfully meet the insulation requirements of automotive work. It is strong, permanently sticky, and it will not fray. It is guaranteed not to dry out.

To prove our confidence in this product we will replace without cost, including transportation charges, any tape found defective within one year from date of manufacture.

Packed as follows: 1-ounce rolls—16 to the carton; 2-ounce rolls—8 to the carton and 8-ounce rolls—1 to the carton.



## Johns-Manville Jewett Ring Packing



Jewett Ring, Style No. 10

**P**ARTICULARLY adapted to packing the water pump shafts on passenger cars and trucks, but can also be used for any condition where rings of small cross-section are required, or where a packing with no rubber content is preferred.

Jewett Rings No. 10 are made of wire-inserted asbestos yarn, braided into jackets, one over another, around a thin lead ribbon. They are then lubricated, graphited and moulded into ring form.

One great advantage Jewett Rings have over other forms of packing, is the amount of labor saved in installation. They make an absolutely tight gland packing, and the garage or repair man can quickly insert this packing in inaccessible places, saving the time usually consumed by winding a braided packing around the rod.

Packed in 1/2-lb. and 1-lb. grease-proof cartons—size and catalog number of the ring contained stamped on each carton.

Write for the Johns-Manville Data Book listing proper sizes of Jewett Rings required for packing water pumps of all makes of cars and trucks. List prices on application.

## Johns-Manville Mogul Twisted Packing

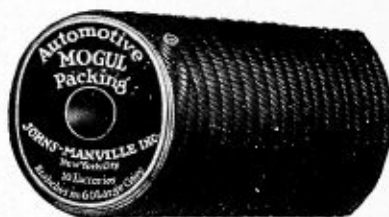

Mogul Twisted, Style No. 193

**J**OHNS-MANVILLE Twisted Mogul Packing is made of long asbestos fibre, which is firmly spun into yarns, and thoroughly lubricated and graphited. The yarns are twisted to make a compact, rope-like packing, which is especially adapted for use on auto pump shafts, transmission shafts, or where stuffing boxes require gland packing of a small size.

This material can be cut to proper length to form rings or to be wound around the shaft until the packing box is filled. It can also be unstranded and re-twisted to form a smaller size when desired for small spaces.

Rubber packings deteriorate in the oil with which they come in contact in automotive use; most composition packings become hard with age. But with Johns-Manville Mogul the quality of the lubrication and the durability of the asbestos assure a packing that will stay soft and give long service. The lubricant has a very high flash point and does not oxidize or deteriorate.

	List Price
1/4 lb. spools (3/16" and 1/4" thick).....	\$0.60
1/4 lb. spools (1/8" thick).....	.75
1 lb. spools (3/16" and 1/4" thick).....	2.40
1 lb. spools (1/8" thick).....	3.00



# Appendix



## APPENDIX

In the following pages are some helpful and reliable tables which will be of great value to the users of this catalog, not only in connection with Johns-Manville products, but as a general reference.

*They contain:*

Examples of How to Use Tables of Pipe Insulation Efficiencies.

Total Heat Loss From Bare Surfaces.

Marks & Davis' Steam Tables.

Tables showing Losses Due to Steam Leakage.

Volume of Water at Various Pressures.

Heat Losses from Uninsulated Hot Surfaces.

Minimum Thicknesses of Insulation for Various Services.

Data on Standard and Wrought Iron Steel Pipe.

Total Radiation Areas and Equivalents of Standard and Extra Heavy Flanged Fittings.

Table of Decimal Equivalents.

Circumferences and Areas of Circles.

Fahrenheit and Centigrade Conversion Table.

Metric Conversion Table.

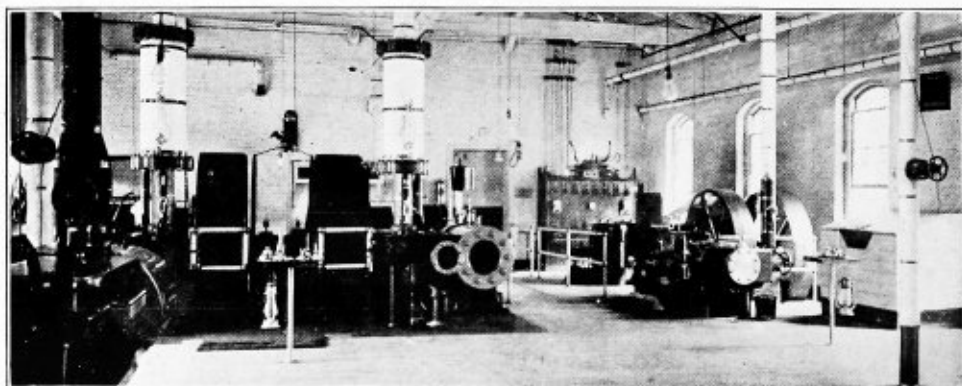



## How to Use Tables of Pipe Insulation Efficiencies

The efficiencies of pipe insulations vary according to the size of the pipe insulated and according to the temperature difference between steam in the pipe and air surrounding the pipe.

The relative values of different insulations may be determined by comparing either their efficiencies or the heat losses through the various types of insulation.

The efficiencies furnish a means of comparing the savings effected by insulations with bare pipe losses. These latter are very large; therefore, a seemingly small difference in efficiency may represent a really large difference in heat losses.

The heat losses may be compared directly as follows:

Bare surface loss .....=100%  
 Efficiency .....=Percent saving  
 $100\% - \% \text{ Efficiency} = \text{Loss through insulation}$   
 expressed as a percentage of bare surface loss.

For example, an insulation which is 90% effi-

cient allows a loss of only 10% of the loss from bare surface.

**EXAMPLE:**—The efficiency of 2" thick Asbesto-Sponge Felted Sheet Insulation at 500° temperature difference is 95.44% and the efficiency of the same insulation 3" thick is 96.85%. The difference in efficiencies is only 1.41% which seems extremely small and might lead one to believe that it would not pay to use the extra inch of thickness.

However, the loss through the 95.44% efficient insulation is 4.56% of the loss from bare surface and the loss through the 96.85% efficient insulation is 3.15% of the loss from bare surface. The difference  $4.56\% - 3.15\% = 1.41\%$ . Therefore, the loss through the 2" thickness is  $(1.41 \div 3.15 =) 45\%$  greater than the loss through the insulation 3" in thickness.

The table on page 244 gives the total heat losses at various temperature differences on bare pipe of different sizes, and on flat surfaces. Tables of efficiencies of the different insulations on various sized pipes and on flat surfaces at various temperature differences are given following the pages describing the insulations.

Use such efficiency tables as follows:

### Example

What is the efficiency of Johns-Manville Asbesto-Sponge Felted Pipe Insulation 2 inches thick to be applied on a 6-inch pipe conveying steam at 200 pounds gauge pressure through a room where temperature is 70° F.?

1. Determine difference between temperature of steam in pipe and air surrounding pipe (see Steam Tables, pages 244 to 247.

Temperature of steam 200 lb. pressure 388° F.  
 Temperature of air around pipe..... 70° F.  
 Difference ..... 318° F.

2. Refer to Table of Efficiencies for 2" thick Asbesto-Sponge Felted Pipe Insulation. Opposite pipe size (6"), you find

Efficiency for 350° F. difference..... 92.6%  
 for 300° F. difference..... 91.9%  
 Difference for 50° ..... .7%

If difference for 50° = .7% then for 1° difference is  $.7 \div 50 = .014\%$ .

The difference you have (318°) is 18° more than 300, so  $18 \times .014 = .252\%$  which, added to 91.9% (efficiency for 300°) = 92.15% the required efficiency.

If you desire to find exactly how much heat is saved by applying this 2" insulation, proceed as follows:

1. Refer to table giving total heat loss in B.t.u. per lineal foot of bare pipe (page 244).

Opposite pipe size (6") and under 300° difference you find loss is 1694.9 B.t.u. per hour. Under 350° difference the loss is 2198.7 B.t.u. Difference in loss for the 50° difference =  $2198.7 - 1694.9 = 503.8$  B.t.u. and for 1° difference it is  $503.8 \div 50 = 10.07$  B.t.u.

2. The difference you have (318°) is 18° more than 300, so  $18 \times 10.07 = 181.3$  B.t.u. which added to 1694.9 = 1876.2 B.t.u., the required total heat loss from 1 lineal foot of the 6" bare pipe per hour.

Having obtained the loss for bare pipe the saving effected by the 2" Asbesto-Sponge Felted Insulation is obtained by multiplying the total loss 1876.2 B.t.u. by the efficiency of the insulation formerly found (92.15%) or 92.15% of  $1876.2 = 1729$  B.t.u. saved per lineal foot per hour.

Results obtained by different thicknesses of insulation or different types of insulation are best determined by comparing heat losses through each.

In order to find the heat loss through the insulation in the above example proceed as follows:

Bare surface loss = 1876.2 B.t.u. per lineal foot per hour.  
 Efficiency = 92.15  
 Percent loss =  $100 - 92.15 = 7.85\%$   
 Loss through insulation 7.85% of  $1876.2 = 147.2$  B.t.u. per lineal foot per hour.



## Total Heat Loss in B. t. u. Per Hour Per Lineal Foot of Bare Pipe of Different Sizes, and Per Square Foot of Flat Surfaces, at Various Temperature Differences

(For finding losses at temperatures between those shown, the B. t. u. Differences per Degree are given in small type between the Main Columns)

Pipe Size lin. ft.	Area of Pipe Sur- face per																			
	50°	100°	150°	200°	Temperature Differences		350°	400°	450°	500°										
	Heat Loss in B. t. u. per lineal ft. per Hour																			
1/8"	.220	21.5	*.52	47.3	*.64	79.2	*.76	117.3	*.90	162.3	*1.06	215.2	*1.28	279.1	*1.52	355.1	*1.93	451.4	*2.37	569.8
1/4"	.274	26.8	.64	59.0	.79	98.6	.96	146.8	1.11	202.1	1.33	268.5	1.58	347.6	1.89	442.2	2.40	562.2	2.05	709.7
3/8"	.344	33.6	.81	74.0	1.00	123.8	1.39	183.4	1.41	253.7	1.67	337.4	1.98	436.5	2.37	555.2	3.03	705.4	3.09	891.
1/2"	.435	42.5	1.01	93.6	1.26	156.6	1.51	231.9	1.58	320.8	2.09	425.4	2.53	551.9	3.00	702.1	3.80	892.6	4.68	1126.7
5/8"	.498	48.7	1.17	107.2	1.44	179.3	1.72	265.4	2.04	367.3	2.39	487.	2.90	631.8	3.44	803.8	4.36	1021.9	5.36	1289.8
3/4"	.622	60.9	1.46	133.9	1.80	223.9	2.15	331.5	2.54	458.7	2.99	608.3	3.62	789.2	4.29	1003.9	5.45	1276.3	6.69	1611.
1"	.753	73.4	1.76	161.6	2.18	270.4	2.60	400.3	3.07	553.9	3.61	734.5	4.37	952.8	5.19	1212.1	6.58	1541.1	8.08	1945.1
1 1/8"	.917	89.6	2.15	197.3	2.66	330.1	3.17	488.8	3.75	676.3	4.41	896.8	5.33	1163.4	6.35	1480.	8.03	1881.7	9.87	2375.
1 1/4"	1.047	102.3	2.46	225.3	3.03	376.9	3.62	558.1	4.28	772.2	5.04	1024.	6.09	1328.4	7.23	1689.9	9.17	2148.4	11.3	2711.7
1 1/2"	1.178	115.1	2.77	253.5	3.41	424.2	4.07	627.9	4.82	868.8	5.67	1152.1	6.85	1494.6	8.13	1901.3	10.3	2417.3	12.7	3051.
1 3/4"	1.309	127.9	3.07	281.5	3.79	470.9	4.53	697.2	5.35	964.7	6.29	1279.2	7.61	1659.5	9.03	2111.1	11.05	2684.	14.1	3387.7
2"	1.456	142.2	3.42	313.1	4.21	523.8	5.03	775.5	5.95	1073.	7.00	1423.	8.40	1846.	10.9	2348.4	12.7	2985.7	15.7	3768.5
2 1/2"	1.734	169.4	4.05	371.9	5.04	623.9	6.00	923.7	7.09	1278.1	8.34	1694.9	10.1	2198.7	12.9	2797.1	15.2	3556.2	18.6	4488.5
3"	2.00	195.0	4.71	430.4	5.79	720.0	6.92	1066.0	8.19	1475.6	9.61	1956.	11.66	2539.	13.78	3228.	17.46	4101.	21.6	5180.
4"	2.257	220.6	5.39	485.7	6.54	812.5	7.84	1203.	9.23	1664.5	10.8	2207.3	13.1	2863.6	15.6	3642.8	19.8	4631.4	24.3	5845.6
5"	2.52	246.0	5.92	542.	7.30	907.	8.72	1343.	10.34	1860.	12.1	2465.	14.7	3200.	17.4	4070.	22.0	5170.	27.2	6530.
6"	2.817	275.4	6.62	606.2	8.16	1014.1	9.75	1501.5	11.5	2077.5	13.6	2755.	16.4	3574.1	19.5	4546.6	24.7	5780.5	30.3	7296.
8"	3.08	300.	7.26	663.	8.92	1109.	10.66	1642.	13.6	2272.	14.76	3010.	17.9	3905.	21.3	4972.	29.9	6315.	33.3	7980.
10"	3.34	326.	7.86	719.	9.68	1203.	11.54	1780.	13.7	2465.	16.02	3266.	19.4	4235.	23.1	5390.	32.2	6850.	36.0	8650.
14" o. d.	3.66	357.	8.59	786.	10.64	1318.	12.94	1950.	15.0	2700.	17.09	3580.	21.3	4645.	25.2	5905.	31.9	7500.	39.5	9475.
16" o. d.	4.19	408.	9.84	901.	12.2	1510.	14.5	2233.	17.2	3095.	20.1	4100.	24.4	5320.	28.9	6765.	36.5	8590.	45.2	10850.
Flat, Curved, or Cylindrical Surfaces.	Heat Loss in B. t. u. per sq. ft. per Hour										Heat Loss in B. t. u. per degree temperature difference per Hour									
	97.5	2.35	215.2	2.90	360.0	3.26	533.0	4.10	737.8	4.80	978.0	5.83	1269.4	6.80	1614.0	8.75	2050.6	10.8	2590.0	
	1.950										2.152									
	2.400										2.665									
	2.951										3.260									
	3.627										4.035									
	4.557										5.180									

\*Example 2" Pipe, 235° Temp. Difference. 235°-200°=35°; 35° x 2.54 (B. t. u. per degree)=88.9 B. t. u. 331.5+88.9=420.4; B. t. u. loss at 235° Temp. difference.

## Steam Table

Reprinted from Marks & Davis' Steam Tables and Diagrams, by permission of the publishers, Longmans, Green & Company

Gauge Press. lbs.	Absol. Press. lbs. p	Temp. Deg. F.	Press. Atmos*	Sp. Vol. cu. ft. per lb. v or s	Density lbs. per cu. ft. l/v	Heat of the liquid h or q	Latent heat of evap. L or r	Total heat of steam H	Internal Energy Evap. l or p	Energy Steam E	Entropy			Gauge Press lbs.
											Water n or h	Evap. L/T or t/T	Steam N or φ	
.....	1	101.83	0.068	333.0	0.00300	69.8	1034.6	1104.4	972.9	1042.7	0.1327	1.8427	1.9754	.....
.....	2	126.15	0.136	173.5	0.00576	94.0	1021.0	1115.0	956.7	1050.7	0.1749	1.7431	1.9180	.....
.....	3	141.52	0.204	118.5	0.00845	109.4	1012.3	1121.6	946.4	1055.8	0.2008	1.6840	1.8848	.....
.....	4	153.01	0.272	90.5	0.01107	120.9	1005.7	1126.5	938.6	1059.5	0.2198	1.6416	1.8614	.....
.....	5	162.28	0.340	73.33	0.01364	130.1	1000.3	1130.5	932.4	1062.5	0.2348	1.6084	1.8432	.....
.....	6	170.06	0.408	61.89	0.01616	137.9	995.8	1133.7	927.0	1064.9	0.2471	1.5814	1.8285	.....
.....	7	176.85	0.476	53.56	0.01867	144.7	991.8	1136.5	922.4	1067.1	0.2579	1.5582	1.8161	.....
.....	8	182.86	0.544	47.27	0.02115	150.8	988.2	1139.0	918.2	1069.0	0.2673	1.5380	1.8053	.....
.....	9	188.27	0.612	42.36	0.02361	156.2	985.0	1141.1	914.4	1070.5	0.2756	1.5202	1.7958	.....
.....	10	193.22	0.680	38.38	0.02606	161.1	982.0	1143.1	910.9	1072.0	0.2832	1.5042	1.7874	.....
.....	11	197.75	0.748	35.10	0.02849	165.7	979.2	1144.9	907.8	1073.4	0.2902	1.4895	1.7797	.....
.....	12	201.96	0.816	32.36	0.03090	169.9	976.6	1146.5	904.8	1074.7	0.2967	1.4760	1.7727	.....
.....	13	205.87	0.885	30.03	0.03330	173.8	974.2	1148.0	902.0	1075.8	0.3025	1.4639	1.7664	.....
.....	14	209.55	0.953	28.02	0.03569	177.5	971.9	1149.4	899.3	1076.8	0.3081	1.4523	1.7604	.....
.....	14.7	212.00	1.000	26.79	0.03732	180.0	970.4	1150.4	897.6	1077.5	0.3118	1.4447	1.7565	0
.....	3	15	213.0	1.021	26.27	0.03806	181.0	969.7	1150.7	1077.8	0.3133	1.4416	1.7549	.....
.....	1.3	16	216.3	1.089	24.79	0.04042	184.4	967.6	1152.0	1078.7	0.3183	1.4311	1.7494	1.3
.....	2.3	17	219.4	1.157	23.38	0.04277	187.5	965.6	1153.1	1079.6	0.3229	1.4215	1.7440	2.3
.....	3.3	18	222.4	1.225	22.16	0.04512	190.5	963.7	1154.2	1080.4	0.3273	1.4127	1.7400	3.3
.....	4.3	19	225.2	1.293	21.07	0.04746	193.4	961.8	1155.2	1081.1	0.3315	1.4045	1.7360	4.3
.....	5.3	20	228.0	1.361	20.08	0.04980	196.1	960.0	1156.2	1081.9	0.3355	1.3965	1.7320	5.3
.....	6.3	21	230.6	1.429	19.18	0.05213	198.8	958.3	1157.1	1082.6	0.3393	1.3887	1.7280	6.3
.....	7.3	22	233.1	1.497	18.37	0.05445	201.3	956.7	1158.0	1083.2	0.3430	1.3811	1.7241	7.3
.....	8.3	23	235.5	1.565	17.62	0.05676	203.8	955.1	1158.8	1083.9	0.3465	1.3739	1.7204	8.3
.....	9.3	24	237.8	1.633	16.93	0.05907	206.1	953.5	1159.6	1084.5	0.3499	1.3670	1.7169	9.3

\* 1 atmo (standard atmosphere) = 760 mms. of Hg. by def. = 29.921 ins. of Hg. = 14.696 lbs. per sq. in. T° = t° + 459.6; J = 777.5 ft. lbs. per B. t. u. [log = 2.89 071]; A = 1/J = 1.286 x 10<sup>-3</sup>; 144 A = 0.1852 [log = 1.26 764].

NOTE.—The gauge pressures are put in only for your guidance in making quick estimates of conditions. Wherever very accurate computations are to be made, find out the atmospheric pressure at your altitude and add this to the gauge pressure and use the resulting absolute pressure in the table.





## Steam Table (Continued)

Gauge Press. lbs.	Absol. Press. lbs. P	Temp. Deg. F t	Press. Atmos*	Sp. Vol. cu. ft. per lb. v or s	Density lbs. per cu. ft. 1/v	Heat of the liquid h or q	Latent heat of evap. L or r	Total heat of steam H	Internal Energy B.t.u.		Entropy			Gauge Press lbs.
									Evap. 1 or e	Steam E	Water n or θ	Evap. L/T or r/T	Steam No or φ	
10.3	25	240.1	1.701	16.30	0.0614	208.4	952.0	1160.4	876.8	1085.1	0.3532	1.3604	1.7136	10.3
11.3	26	242.2	1.769	15.72	0.0636	210.6	950.6	1161.2	875.1	1085.6	0.3564	1.3542	1.7106	11.3
12.3	27	244.4	1.837	15.18	0.0659	212.7	949.2	1161.9	873.5	1086.2	0.3594	1.3483	1.7077	12.3
13.3	28	246.4	1.905	14.67	0.0682	214.8	947.8	1162.6	872.0	1086.7	0.3623	1.3425	1.7048	13.3
14.3	29	248.4	1.973	14.19	0.0705	216.8	946.4	1163.2	870.5	1087.2	0.3652	1.3367	1.7019	14.3
15.3	30	250.3	2.041	13.74	0.0728	218.8	945.1	1163.9	869.0	1087.7	0.3680	1.3311	1.6991	15.3
16.3	31	252.2	2.109	13.32	0.0751	220.7	943.8	1164.5	867.6	1088.2	0.3707	1.3257	1.6964	16.3
17.3	32	254.1	2.178	12.93	0.0773	222.6	942.5	1165.1	866.2	1088.6	0.3733	1.3205	1.6938	17.3
18.3	33	255.8	2.246	12.57	0.0795	224.4	941.3	1165.7	864.8	1089.1	0.3759	1.3155	1.6914	18.3
19.3	34	257.6	2.314	12.22	0.0818	226.2	940.1	1166.3	863.4	1089.5	0.3784	1.3107	1.6891	19.3
20.3	35	259.3	2.382	11.89	0.0841	227.9	938.9	1166.8	862.1	1089.9	0.3808	1.3060	1.6868	20.3
21.3	36	261.0	2.450	11.58	0.0863	229.6	937.7	1167.3	860.8	1090.3	0.3832	1.3014	1.6846	21.3
22.3	37	262.6	2.518	11.29	0.0886	231.3	936.6	1167.8	859.5	1090.7	0.3855	1.2969	1.6824	22.3
23.3	38	264.2	2.586	11.01	0.0908	232.9	935.5	1168.4	858.3	1091.0	0.3877	1.2925	1.6802	23.3
24.3	39	265.8	2.654	10.74	0.0931	234.5	934.4	1168.9	857.1	1091.4	0.3899	1.2882	1.6781	24.3
25.3	40	267.3	2.722	10.49	0.0953	236.1	933.3	1169.4	855.9	1091.8	0.3920	1.2841	1.6761	25.3
26.3	41	268.7	2.790	10.25	0.0976	237.6	932.2	1169.8	854.7	1092.2	0.3941	1.2800	1.6741	26.3
27.3	42	270.2	2.858	10.02	0.0998	239.1	931.2	1170.3	853.6	1092.5	0.3962	1.2759	1.6721	27.3
28.3	43	271.7	2.926	9.80	0.1020	240.5	930.2	1170.7	852.4	1092.8	0.3982	1.2720	1.6702	28.3
29.3	44	273.1	2.994	9.59	0.1043	242.0	929.2	1171.2	851.3	1093.2	0.4002	1.2681	1.6683	29.3
30.3	45	274.5	3.062	9.39	0.1065	243.4	928.2	1171.6	850.3	1093.5	0.4021	1.2644	1.6665	30.3
31.3	46	275.8	3.130	9.20	0.1087	244.8	927.2	1172.0	849.2	1093.8	0.4040	1.2607	1.6647	31.3
32.3	47	277.2	3.198	9.02	0.1109	246.1	926.3	1172.4	848.1	1094.1	0.4059	1.2571	1.6630	32.3
33.3	48	278.5	3.266	8.84	0.1131	247.5	925.3	1172.8	847.1	1094.4	0.4077	1.2536	1.6613	33.3
34.3	49	279.8	3.334	8.67	0.1153	248.8	924.4	1173.2	846.1	1094.7	0.4095	1.2502	1.6597	34.3
35.3	50	281.0	3.402	8.51	0.1175	250.1	923.5	1173.6	845.0	1095.0	0.4113	1.2468	1.6581	35.3
36.3	51	282.3	3.470	8.35	0.1197	251.4	922.6	1174.0	844.0	1095.3	0.4130	1.2435	1.6565	36.3
37.3	52	283.5	3.538	8.20	0.1219	252.6	921.7	1174.3	843.1	1095.5	0.4147	1.2402	1.6549	37.3
38.3	53	284.7	3.606	8.05	0.1241	253.9	920.8	1174.7	842.1	1095.8	0.4164	1.2370	1.6534	38.3
39.3	54	285.9	3.674	7.91	0.1263	255.1	919.9	1175.0	841.1	1096.1	0.4180	1.2339	1.6519	39.3
40.3	55	287.1	3.742	7.78	0.1285	256.3	919.0	1175.4	840.2	1096.3	0.4196	1.2309	1.6505	40.3
41.3	56	288.2	3.810	7.65	0.1307	257.5	918.2	1175.7	839.3	1096.6	0.4212	1.2278	1.6490	41.3
42.3	57	289.4	3.878	7.52	0.1329	258.7	917.4	1176.0	838.3	1096.8	0.4227	1.2248	1.6475	42.3
43.3	58	290.5	3.947	7.40	0.1350	259.8	916.5	1176.4	837.4	1097.1	0.4242	1.2218	1.6460	43.3
44.3	59	291.6	4.015	7.28	0.1372	261.0	915.7	1176.7	836.5	1097.3	0.4257	1.2189	1.6446	44.3
45.3	60	292.7	4.083	7.17	0.1394	262.1	914.9	1177.0	835.6	1097.6	0.4272	1.2160	1.6432	45.3
46.3	61	293.8	4.151	7.06	0.1416	263.2	914.1	1177.3	834.8	1097.8	0.4287	1.2132	1.6419	46.3
47.3	62	294.9	4.219	6.95	0.1438	264.3	913.3	1177.6	833.9	1098.0	0.4302	1.2104	1.6406	47.3
48.3	63	295.9	4.287	6.85	0.1460	265.4	912.5	1177.9	833.1	1098.2	0.4316	1.2077	1.6393	48.3
49.3	64	297.0	4.355	6.75	0.1482	266.4	911.8	1178.2	832.2	1098.4	0.4330	1.2050	1.6380	49.3
50.3	65	298.0	4.423	6.65	0.1503	267.5	911.0	1178.5	831.4	1098.7	0.4344	1.2024	1.6368	50.3
51.3	66	299.0	4.491	6.56	0.1525	268.5	910.2	1178.8	830.5	1098.9	0.4358	1.1998	1.6356	51.3
52.3	67	300.0	4.559	6.47	0.1547	269.6	909.5	1179.0	829.7	1099.1	0.4371	1.1972	1.6333	52.3
53.3	68	301.0	4.627	6.38	0.1569	270.6	908.7	1179.3	828.9	1099.3	0.4385	1.1946	1.6311	53.3
54.3	69	302.0	4.695	6.29	0.1590	271.6	908.0	1179.6	828.1	1099.5	0.4398	1.1921	1.6319	54.3
55.3	70	302.9	4.763	6.20	0.1612	272.6	907.2	1179.8	827.3	1099.7	0.4411	1.1896	1.6307	55.3
56.3	71	303.9	4.831	6.12	0.1634	273.6	906.5	1180.1	826.5	1099.9	0.4424	1.1872	1.6296	56.3
57.3	72	304.8	4.899	6.04	0.1656	274.5	905.8	1180.4	825.8	1100.1	0.4437	1.1848	1.6285	57.3
58.3	73	305.8	4.967	5.96	0.1678	275.5	905.1	1180.6	825.0	1100.3	0.4449	1.1825	1.6274	58.3
59.3	74	306.7	5.035	5.89	0.1699	276.5	904.4	1180.9	824.2	1100.5	0.4462	1.1801	1.6263	59.3
60.3	75	307.6	5.103	5.81	0.1721	277.4	903.7	1181.1	823.5	1100.6	0.4474	1.1778	1.6252	60.3
61.3	76	308.5	5.171	5.74	0.1743	278.3	903.0	1181.4	822.7	1100.8	0.4487	1.1755	1.6242	61.3
62.3	77	309.4	5.239	5.67	0.1764	279.3	902.3	1181.6	822.0	1101.0	0.4499	1.1732	1.6231	62.3
63.3	78	310.3	5.307	5.60	0.1786	280.2	901.7	1181.8	821.3	1101.2	0.4511	1.1710	1.6221	63.3
64.3	79	311.2	5.375	5.54	0.1808	281.1	901.0	1182.1	820.6	1101.4	0.4523	1.1687	1.6210	64.3
65.3	80	312.0	5.444	5.47	0.1829	282.0	900.3	1182.3	819.8	1101.6	0.4535	1.1665	1.6200	65.3
66.3	81	312.9	5.512	5.41	0.1851	282.9	899.7	1182.5	819.1	1101.7	0.4546	1.1644	1.6190	66.3
67.3	82	313.8	5.580	5.34	0.1873	283.8	899.0	1182.8	818.4	1101.9	0.4557	1.1623	1.6180	67.3
68.3	83	314.6	5.648	5.28	0.1894	284.6	898.4	1183.0	817.7	1102.1	0.4568	1.1602	1.6170	68.3
69.3	84	315.4	5.716	5.22	0.1915	285.5	897.7	1183.2	817.0	1102.2	0.4579	1.1581	1.6160	69.3
70.3	85	316.3	5.784	5.16	0.1937	286.3	897.1	1183.4	816.3	1102.4	0.4590	1.1561	1.6151	70.3
71.3	86	317.1	5.852	5.10	0.1959	287.2	896.4	1183.6	815.6	1102.6	0.4601	1.1540	1.6141	71.3
72.3	87	317.9	5.920	5.05	0.1980	288.0	895.8	1183.8	815.0	1102.7	0.4612	1.1520	1.6132	72.3
73.3	88	318.7	5.988	5.00	0.2001	288.9	895.2	1184.0	814.3	1102.9	0.4623	1.1500	1.6123	73.3
74.3	89	319.5	6.056	4.94	0.2023	289.7	894.6	1184.2	813.6	1103.0	0.4633	1.1481	1.6114	74.3
75.3	90	320.3	6.124	4.89	0.2044	290.5	893.9	1184.4	813.0	1103.2	0.4644	1.1461	1.6105	75.3
76.3	91	321.1	6.192	4.84	0.2065	291.3	893.3	1184.6	812.3	1103.3	0.4654	1.1442	1.6096	76.3
77.3	92	321.8	6.260	4.79	0.2087	292.1	892.7	1184.8	811.7	1103.5	0.4664	1.1423	1.6087	77.3
78.3	93	322.6	6.328	4.74	0.2109	292.9	892.1	1185.0	811.0	1103.6	0.4674	1.1404	1.6078	78.3
79.3	94	323.4	6.396	4.69	0.2130	293.7	891.5	1185.2	810.4	1103.8	0.4684	1.1385	1.6069	79.3
80.3	95	324.1	6.464	4.65	0.2151	294.5	890.9	1185.4	809.7	1103.9	0.4694	1.1367	1.6061	80.3
81.3	96	324.9	6.532	4.60	0.2172	295.3	890.3	1185.6	809.1	1104.1	0.4704	1.1348	1.6052	81.3
82.3	97	325.6	6.600	4.56	0.2193	296.1	889.7	1185.8	808.5	1104.2	0.4714	1.1330	1.6044	82.3
83.3	98	326.4	6.668	4.51	0.2215	296.8	889.2	1186.0	807.9	1104.4	0.4724	1.1312	1.6036	83.3
84.3	99	327.1	6.736	4.47	0.2237	297.6	888.6	1186.2	807.2	1104.5	0.4733	1.1295	1.6028	84.3

\* 1 atmo (standard atmosphere) = 760 mms. of Hg. by def. = 29.921 ins. of Hg. = 14.696 lbs. per sq. in.  
 $T^{\circ}C = t^{\circ}F + 459.6$ ;  $J = 777.5$  ft. lbs. per B.t.u. [log = 2.89 071];  $A = 1/J = 1.286 \times 10^{-3}$ ;  $144 A = 0.1852$  [log = 1.26 664].



## Steam Table

(Continued)

Gauge Press. lbs.	Absol. Press. lbs. p	Temp. Deg. F. t	Press. Atmos* —	Sp. Vol. cu. ft. per lb. v or s	Density lbs. per cu. ft. 1/v	Heat of the liquid h or q	Latent heat of evap. L or r	Total heat of steam H	Internal Energy B.t.u.		Entropy			Gauge Press. lbs.
									Evap. l or ρ	Steam E	Water n or θ	Evap. L/T or r/T	Steam N or φ	
85.3	100	327.8	6.80	4.429	0.2258	298.3	888.0	1186.3	806.6	1104.6	0.4743	1.1277	1.6020	85.3
86.3	101	328.6	6.87	4.388	0.2279	299.1	887.4	1186.5	806.0	1104.8	0.4752	1.1260	1.6012	86.3
87.3	102	329.3	6.94	4.347	0.2300	299.8	886.9	1186.7	805.4	1104.9	0.4762	1.1242	1.6004	87.3
88.3	103	330.0	7.01	4.307	0.2322	300.6	886.3	1186.9	804.8	1105.0	0.4771	1.1225	1.5996	88.3
89.3	104	330.7	7.08	4.268	0.2343	301.3	885.8	1187.0	804.2	1105.1	0.4780	1.1208	1.5988	89.3
90.3	105	331.4	7.14	4.230	0.2365	302.0	885.2	1187.2	803.6	1105.3	0.4789	1.1191	1.5980	90.3
91.3	106	332.0	7.21	4.192	0.2386	302.7	884.7	1187.4	803.0	1105.4	0.4798	1.1174	1.5972	91.3
92.3	107	332.7	7.28	4.155	0.2408	303.4	884.1	1187.5	802.5	1105.5	0.4807	1.1158	1.5965	92.3
93.3	108	333.4	7.35	4.118	0.2429	304.1	883.6	1187.7	801.9	1105.7	0.4816	1.1141	1.5957	93.3
94.3	109	334.1	7.42	4.082	0.2450	304.8	883.0	1187.9	801.3	1105.8	0.4825	1.1125	1.5950	94.3
95.3	110	334.8	7.49	4.047	0.2472	305.5	882.5	1188.0	800.7	1105.9	0.4834	1.1108	1.5942	95.3
96.3	111	335.4	7.55	4.012	0.2493	306.2	881.9	1188.2	800.2	1106.0	0.4843	1.1092	1.5935	96.3
97.3	112	336.1	7.62	3.978	0.2514	306.9	881.4	1188.4	799.6	1106.2	0.4852	1.1076	1.5928	97.3
98.3	113	336.8	7.69	3.945	0.2535	307.6	880.9	1188.5	799.0	1106.3	0.4860	1.1061	1.5921	98.3
99.3	114	337.4	7.76	3.912	0.2556	308.3	880.4	1188.7	798.5	1106.4	0.4869	1.1045	1.5914	99.3
100.3	115	338.1	7.83	3.880	0.2577	309.0	879.8	1188.8	797.9	1106.5	0.4877	1.1030	1.5907	100.3
102.3	117	339.4	7.96	3.817	0.2620	310.3	878.8	1189.1	796.8	1106.8	0.4894	1.0999	1.5893	102.3
104.3	119	340.6	8.10	3.756	0.2662	311.6	877.8	1189.4	795.7	1107.0	0.4911	1.0969	1.5880	104.3
106.3	121	341.9	8.23	3.697	0.2705	313.0	876.7	1189.7	794.7	1110.2	0.4927	1.0938	1.5866	106.3
108.3	123	343.2	8.37	3.639	0.2748	314.3	875.7	1190.0	793.6	1110.4	0.4943	1.0910	1.5853	108.3
110.3	125	344.4	8.50	3.583	0.2791	315.5	874.7	1190.3	792.6	1110.7	0.4959	1.0880	1.5839	110.3
112.3	127	345.6	8.64	3.530	0.2833	316.8	873.8	1190.5	791.5	1110.9	0.4974	1.0851	1.5825	112.3
114.3	129	346.8	8.78	3.478	0.2875	318.0	872.8	1190.8	790.5	1110.8	0.4990	1.0823	1.5813	114.3
116.3	131	348.0	8.91	3.427	0.2918	319.3	871.8	1191.1	789.5	1110.3	0.5005	1.0796	1.5801	116.3
118.3	133	349.1	9.05	3.378	0.2960	320.5	870.9	1191.3	788.5	1110.5	0.5020	1.0769	1.5789	118.3
120.3	135	350.3	9.19	3.331	0.3002	321.7	869.9	1191.6	787.5	1110.7	0.5035	1.0742	1.5777	120.3
122.3	137	351.4	9.32	3.285	0.3044	322.8	869.0	1191.8	786.5	1110.9	0.5050	1.0715	1.5765	122.3
124.3	139	352.5	9.46	3.241	0.3086	324.0	868.1	1192.1	785.5	1110.9	0.5064	1.0689	1.5753	124.3
126.3	141	353.6	9.59	3.197	0.3129	325.2	867.2	1192.3	784.6	1110.3	0.5079	1.0662	1.5741	126.3
128.3	143	354.7	9.73	3.154	0.3171	326.3	866.3	1192.6	783.6	1110.5	0.5093	1.0637	1.5730	128.3
130.3	145	355.8	9.87	3.112	0.3213	327.4	865.4	1192.8	782.7	1110.6	0.5107	1.0612	1.5719	130.3
132.3	147	356.9	10.00	3.072	0.3255	328.6	864.5	1193.0	781.7	1110.8	0.5121	1.0587	1.5708	132.3
134.3	149	357.9	10.14	3.033	0.3297	329.7	863.6	1193.3	780.8	1110.0	0.5135	1.0562	1.5697	134.3
136.3	151	359.0	10.28	2.993	0.3341	330.8	862.7	1193.5	779.9	1110.2	0.5148	1.0538	1.5686	136.3
138.3	153	360.0	10.41	2.956	0.3383	331.9	861.8	1193.7	779.0	1110.4	0.5162	1.0513	1.5675	138.3
140.3	155	361.0	10.55	2.920	0.3425	332.9	861.0	1194.0	778.1	1110.5	0.5175	1.0489	1.5664	140.3
142.3	157	362.1	10.68	2.885	0.3467	334.0	860.1	1194.2	777.2	1110.7	0.5188	1.0466	1.5654	142.3
144.3	159	363.1	10.82	2.861	0.3508	335.1	859.3	1194.4	776.3	1110.8	0.5201	1.0443	1.5644	144.3
146.3	161	364.1	10.96	2.818	0.3549	336.2	858.4	1194.6	775.4	1111.0	0.5214	1.0420	1.5634	146.3
148.3	163	365.1	11.09	2.785	0.3591	337.2	857.6	1194.8	774.5	1111.2	0.5226	1.0398	1.5624	148.3
150.3	165	366.0	11.23	2.753	0.3633	338.2	856.8	1195.0	773.6	1111.3	0.5239	1.0376	1.5615	150.3
152.3	167	367.0	11.36	2.721	0.3675	339.2	855.9	1195.2	772.8	1111.4	0.5251	1.0354	1.5605	152.3
154.3	169	368.0	11.50	2.690	0.3717	340.2	855.1	1195.4	771.9	1111.6	0.5263	1.0332	1.5595	154.3
156.3	171	368.9	11.64	2.660	0.3759	341.2	854.3	1195.5	771.1	1111.7	0.5275	1.0311	1.5586	156.3
158.3	173	369.9	11.77	2.631	0.3801	342.2	853.5	1195.7	770.2	1111.9	0.5287	1.0289	1.5576	158.3
160.3	175	370.8	11.91	2.602	0.3843	343.2	852.7	1195.9	769.4	1112.0	0.5299	1.0268	1.5567	160.3
162.3	177	371.7	12.04	2.574	0.3885	344.2	851.9	1196.1	768.6	1112.2	0.5311	1.0246	1.5557	162.3
164.3	179	372.7	12.18	2.547	0.3927	345.2	851.2	1196.3	767.8	1112.4	0.5322	1.0225	1.5547	164.3
166.3	181	373.6	12.32	2.520	0.3969	346.1	850.4	1196.5	767.0	1112.5	0.5334	1.0205	1.5539	166.3
168.3	183	374.5	12.45	2.494	0.4010	347.1	849.6	1196.7	766.2	1112.6	0.5345	1.0185	1.5530	168.3
170.3	185	375.4	12.59	2.468	0.4052	348.0	848.8	1196.8	765.4	1112.8	0.5356	1.0164	1.5520	170.3
172.3	187	376.3	12.72	2.443	0.4094	349.0	848.0	1197.0	764.6	1112.9	0.5367	1.0144	1.5511	172.3
174.3	189	377.2	12.86	2.418	0.4136	349.9	847.3	1197.2	763.8	1113.0	0.5378	1.0124	1.5502	174.3
176.3	191	378.0	13.00	2.393	0.4178	350.8	846.5	1197.3	763.0	1113.2	0.5389	1.0105	1.5494	176.3
178.3	193	378.9	13.13	2.369	0.4220	351.7	845.8	1197.5	762.2	1113.3	0.5400	1.0085	1.5485	178.3
180.3	195	379.8	13.27	2.346	0.4262	352.7	845.0	1197.7	761.4	1113.4	0.5410	1.0066	1.5476	180.3
182.3	197	380.6	13.40	2.323	0.4304	353.6	844.3	1197.8	760.7	1113.6	0.5421	1.0047	1.5468	182.3
184.3	199	381.4	13.54	2.301	0.4346	354.4	843.6	1198.0	759.9	1113.7	0.5431	1.0029	1.5460	184.3
186.3	201	382.3	13.68	2.279	0.4389	355.3	842.8	1198.2	759.2	1113.8	0.5442	1.0010	1.5452	186.3
188.3	203	383.1	13.81	2.258	0.4431	356.2	842.1	1198.3	758.4	1113.9	0.5452	0.9992	1.5444	188.3
190.3	205	384.0	13.95	2.237	0.4473	357.1	841.4	1198.5	757.6	1114.0	0.5463	0.9973	1.5436	190.3
192.3	207	384.8	14.08	2.217	0.4515	358.0	840.6	1198.6	756.9	1114.2	0.5473	0.9955	1.5428	192.3
194.3	209	385.6	14.22	2.197	0.4557	358.8	839.9	1198.8	756.2	1114.3	0.5483	0.9937	1.5420	194.3
196.3	211	386.4	14.36	2.177	0.4599	359.6	839.3	1198.9	755.5	1114.4	0.5493	0.9920	1.5413	196.3
198.3	213	387.2	14.49	2.158	0.4641	360.5	838.6	1199.1	754.7	1114.5	0.5503	0.9902	1.5405	198.3
200.3	215	388.0	14.63	2.138	0.4683	361.4	837.9	1199.2	754.0	1114.6	0.5513	0.9885	1.5398	200.3
202.3	217	388.8	14.77	2.118	0.4725	362.2	837.2	1199.4	753.3	1114.7	0.5523	0.9867	1.5390	202.3
204.3	219	389.5	14.90	2.100	0.4767	363.0	836.5	1199.5	752.6	1114.8	0.5533	0.9850	1.5383	204.3
206.3	221	390.3	15.04	2.082	0.4809	363.8	835.8	1199.6	751.9	1115.0	0.5543	0.9833	1.5376	206.3
208.3	223	391.1	15.17	2.064	0.4851	364.6	835.1	1199.8	751.2	1115.1	0.5553	0.9816	1.5369	208.3
210.3	225	391.9	15.31	2.046	0.4893	365.5	834.4	1199.9	750.5	1115.2	0.5562	0.9799	1.5361	210.3
212.3	227	392.6	15.45	2.030	0.4935	366.3	833.8	1200.0	749.8	1115.3	0.5572	0.9783	1.5355	212.3
214.3	229	393.4	15.58	2.013	0.4977	367.1	833.1	1200.2	749.1	1115.4	0.5582	0.9766	1.5348	214.3

\*1 atmo (standard atmosphere) = 760 mms. of Hg. by definition = 29.921 ins. of Hg. = 14.696 lbs. per sq. in.  
 $T^{\circ} = t^{\circ} + 459.6$ ;  $J = 777.5$  ft. lbs. per B.t.u. [ $\log = 2.89$  071];  $A = 1/2 = 1.286 \times 10^{-3}$ ;  $144 A = 0.1852$  [ $\log = 1.26$  664].  
 NOTE.—The gauge pressures are put in only for your guidance in making quick estimates of conditions. Wherever very accurate computations are to be made, find out the atmospheric pressure at your altitude and add this to the gauge pressure and use the resulting absolute pressure in the table.



## Steam Table—(Continued)

Gauge Press. lbs.	Absol. Press. lbs. p	Temp. Deg. F. t	Press. Atmos* —	Sp. Vol. cu. ft. per lb. v or s	Density lbs. per cu. ft. 1/v	Heat of the liquid h or q	Latent heat of evap. h or r	Total heat of steam H	Internal Energy B.t.u.		Entropy		Gauge Press lbs.	
									Evap. l or o	Steam E	Water no r 0	Evap. L/T or r/T		Steam N or o
216.3	231	394.1	15.72	1.996	0.501	367.9	832.4	1200.3	748.4	1115.5	0.5591	0.9750	1.5341	216.3
218.3	233	394.9	15.86	1.980	0.505	368.7	831.8	1200.4	747.7	1115.6	0.5601	0.9733	1.5334	218.3
220.3	235	395.6	15.99	1.964	0.509	369.4	831.1	1200.6	747.0	1115.7	0.5610	0.9717	1.5327	220.3
222.3	237	396.4	16.13	1.948	0.513	370.2	830.4	1200.7	746.4	1115.8	0.5619	0.9700	1.5319	222.3
224.3	239	397.1	16.26	1.932	0.518	371.0	829.8	1200.8	745.7	1115.9	0.5629	0.9684	1.5313	224.3
226.3	241	397.8	16.40	1.917	0.522	371.8	829.2	1200.9	745.0	1116.0	0.5638	0.9668	1.5306	226.3
228.3	243	398.5	16.53	1.902	0.526	372.6	828.5	1201.1	744.4	1116.1	0.5647	0.9653	1.5300	228.3
230.3	245	399.3	16.67	1.887	0.530	373.3	827.9	1201.2	743.7	1116.2	0.5655	0.9638	1.5293	230.3
232.3	247	400.0	16.81	1.872	0.534	374.1	827.2	1201.3	743.0	1116.3	0.5663	0.9623	1.5286	232.3
234.3	249	400.7	16.94	1.857	0.538	374.8	826.6	1201.4	742.4	1116.4	0.5672	0.9607	1.5279	234.3
235.3	250	401.1	17.01	1.850	0.541	375.2	826.3	1201.5	742.0	1116.4	0.5676	0.9600	1.5276	235.3
237.3	252	401.8	17.15	1.836	0.545	376.0	825.6	1201.6	741.4	1116.5	0.5685	0.9584	1.5269	237.3
239.3	254	402.4	17.28	1.822	0.549	376.7	825.0	1201.7	740.8	1116.6	0.5694	0.9569	1.5263	239.3
241.3	256	403.1	17.42	1.809	0.553	377.5	824.4	1201.8	740.1	1116.7	0.5702	0.9554	1.5256	241.3
243.3	258	403.8	17.56	1.795	0.557	378.2	823.7	1201.9	739.5	1116.8	0.5711	0.9539	1.5250	243.3
245.3	260	404.5	17.69	1.782	0.561	378.9	823.1	1202.1	738.9	1116.9	0.5719	0.9525	1.5244	245.3
247.3	262	405.2	17.83	1.769	0.565	379.6	822.5	1202.2	738.2	1117.0	0.5727	0.9511	1.5238	247.3
249.3	264	405.9	17.96	1.756	0.569	380.4	821.9	1202.3	737.6	1117.1	0.5735	0.9497	1.5232	249.3
251.3	266	406.6	18.10	1.743	0.574	381.1	821.3	1202.4	737.0	1117.2	0.5744	0.9482	1.5226	251.3
253.3	268	407.2	18.24	1.731	0.578	381.8	820.7	1202.5	736.4	1117.2	0.5752	0.9468	1.5220	253.3
255.3	270	407.9	18.37	1.718	0.582	382.5	820.1	1202.6	735.8	1117.3	0.5760	0.9454	1.5214	255.3
257.3	272	408.6	18.51	1.705	0.587	383.2	819.5	1202.7	735.1	1117.4	0.5768	0.9440	1.5208	257.3
259.3	274	409.2	18.64	1.693	0.591	383.9	818.9	1202.8	734.5	1117.5	0.5776	0.9426	1.5202	259.3
261.3	276	409.9	18.78	1.681	0.595	384.6	818.3	1202.9	733.9	1117.6	0.5784	0.9412	1.5196	261.3
263.3	278	410.5	18.92	1.669	0.599	385.3	817.7	1203.0	733.3	1117.6	0.5792	0.9398	1.5190	263.3
265.3	280	411.2	19.05	1.658	0.603	386.0	817.1	1203.1	732.7	1117.7	0.5800	0.9385	1.5185	265.3
267.3	282	411.8	19.19	1.646	0.608	386.7	816.5	1203.2	732.1	1117.8	0.5808	0.9371	1.5179	267.3
269.3	284	412.4	19.32	1.635	0.612	387.4	815.9	1203.3	731.5	1117.9	0.5816	0.9357	1.5173	269.3
271.3	286	413.1	19.46	1.624	0.616	388.1	815.4	1203.4	730.9	1118.0	0.5824	0.9344	1.5168	271.3
273.3	288	413.7	19.60	1.613	0.620	388.7	814.8	1203.5	730.3	1118.1	0.5832	0.9330	1.5162	273.3
275.3	290	414.4	19.73	1.602	0.624	389.4	814.2	1203.6	729.7	1118.1	0.5840	0.9316	1.5156	275.3
277.3	292	415.0	19.87	1.591	0.629	390.1	813.6	1203.7	729.2	1118.2	0.5848	0.9302	1.5150	277.3
279.3	294	415.6	20.01	1.581	0.633	390.8	813.0	1203.8	728.6	1118.3	0.5856	0.9289	1.5145	279.3
281.3	296	416.2	20.14	1.571	0.637	391.4	812.5	1203.9	728.0	1118.4	0.5863	0.9276	1.5139	281.3
283.3	298	416.8	20.28	1.561	0.641	392.1	811.9	1204.0	727.4	1118.4	0.5871	0.9263	1.5134	283.3
285.3	300	417.5	20.41	1.551	0.645	392.7	811.3	1204.1	726.8	1118.5	0.5878	0.9251	1.5129	285.3
295.3	310	420.5	21.09	1.502	0.666	395.9	808.5	1204.5	724.0	1118.9	0.5915	0.9187	1.5102	295.3
305.3	320	423.4	21.78	1.456	0.687	399.1	805.8	1204.9	721.2	1119.2	0.5951	0.9125	1.5076	305.3
355.3	370	437.2	25.18	1.264	0.791	414.0	792.8	1206.8	708.2	1120.8	0.6116	0.8840	1.4956	355.3
375.3	390	442.3	26.54	1.200	0.833	419.5	787.9	1207.4	703.3	1121.4	0.6178	0.8737	1.4915	375.3
385.3	400	444.7	27.22	1.17	0.86	422.	786.	1208.	701.	1122.	0.621	0.868	1.489	385.3
405.3	420	449.6	28.58	1.11	0.90	427.	780.	1208.	696.	1122.	0.627	0.858	1.485	405.3
455.3	470	460.9	31.98	0.99	1.01	440.	769.	1209.	685.	1123.	0.640	0.835	1.475	455.3
510.3	525	472.3	35.72	0.89	1.12	453.	757.	1210.	673.	1124.	0.654	0.813	1.467	510.3
560.3	575	481.9	39.13	0.81	1.24	464.	747.	1211.	663.	1125.	0.664	0.794	1.458	560.3
585.3	600	486.4	40.83	0.78	1.28	469.	742.	1211.	658.	1125.	0.670	0.784	1.454	585.3

\*1 atmo (standard atmosphere) = 760 mms. of Hg. by definition = 29.921 ins. of Hg. = 14.696 lbs. per sq. in.  
 T° = t° + 459.6; J = 777.5 ft. lbs. per B.t.u. [log = 2.89 071]; A = 1/1 = 1.286 X 10<sup>-3</sup>; 144 A = 0.1852 [log = 1.26 764].  
 NOTE.—The gauge pressures are put in only for your guidance in making quick estimates of conditions. Wherever very accurate computations are to be made, find out the atmospheric pressure at your altitude and add this to the gauge pressure and use the resulting absolute pressure in the table.

## Table showing Loss due to Steam-leakage

SIZE OF OPENING	AIR		STEAM		WATER	
	Number of Cu. Ft. Wasted per Mo. @ 100 lbs. Pressure	Total Cost of Waste per Mo. @ 10c. per M. Cu. Ft.	Number of Pounds Wasted per Mo. @ 100 lbs. Pressure	Total Cost of Waste per Mo. @ 60c. per M. lbs.	Number of Gals. Wasted per Mo. @ 42 lbs. Pressure	Total Cost of Waste per Mo. @ 15 1/2c. per M. Gals.
1/2"	17,798,400	\$1,779.84	805,000	\$483.00	1,231,000	\$192.00
3/8"	9,979,200	997.92	460,000	276.00	692,400	108.00
1/4"	4,449,600	444.96	203,000	121.80	307,700	48.00
1/8"	1,114,560	111.46	50,500	30.30	76,900	12.00
1/16"	278,640	27.86	12,750	7.65	19,200	3.00
1/32"	69,552	6.96	3,175	1.91	4,800	.80

This Table was prepared by the Rock Island Railroad and posted on their bulletin boards. This Table has a direct application to Steam Traps, Piston and Plunger Packings and Sheet Packing. Johns-Manville Traps do not air bind. The pet cock with which they are furnished does not have to be "cracked" to allow air to pass off and keep the trap functioning properly. The quantity of steam which is lost through open steam pet cocks is convincingly shown in the chart. As regards Packings, the chart is of assistance in showing how necessary it is to maintain packing boxes and flanges in steam lines in a proper state of tightness.



## Volume of Water at Various Pressures

At Saturation Temperatures Corresponding to Pressures Given.

Gauge Pressure, Lbs. Per Sq. In.	Absolute Pressure, Lbs. Per Sq. In.	Specific Volume, V' or O Cu. Ft. Per Lb.	Density, $\downarrow$ , Lbs. Per Cu. Ft.	Energy of Expansion, 144 Ap V' B. t. u.
.3	15	0.0167	59.8	0.05
25.3	40	0.0171	58.3	0.13
50.3	65	0.0174	57.4	0.21
75.3	90	0.0176	56.8	0.30
100.3	115	0.0178	56.0	0.38
125.3	140	0.0180	55.4	0.47
150.3	165	0.0182	54.9	0.56
175.3	190	0.0184	54.5	0.65
200.3	215	0.0185	54.0	0.74
225.3	240	0.0186	53.6	0.83
265.3	280	0.0189	53.0	0.98
435.3	450	0.0197	50.8	1.65

## Heat Losses from Uninsulated Hot Surfaces

ORDINARY STEAM TEMPERATURES Temperature of Surrounding Air 70° F.					
Steam Pressure (Gauge)	Steam Temperature (Deg. Fahr.)	Difference between Temper- ature of Steam and Sur- rounding Air (Deg. Fahr.)	Loss Per Sq. Ft. Per Hour (B.t.u.)	Waste of Coal in Lbs. Per Sq. Ft. Per Year	Number of Sq. Ft. of Surface That Wastes a Ton of Coal in 1 Year
0	212	142	334	293	6.82
10	240	170	425	372	5.38
25	267	197	522.5	458	4.37
50	298	228	644	564	3.55
75	320	250	737.5	646	3.10
100	338	268	820	718	2.79
150	366	296	960	840	2.38
200	388	318	1,079	945	2.12
250	406	336	1,184	1,036	1.93
TEMPERATURES LOWER THAN 212 DEG. F.					
	Surface Temperature (Deg. Fahr.)	Difference Between Surface Temperature and Surrounding Air (Deg. Fahr.)	Loss Per Sq. Ft. Per Hour (B.t.u.)	Waste of Coal in Lbs. Per Sq. Ft. Per Year	Number of Sq. Ft. of Surface That Wastes a Ton of Coal in 1 Year
	100	30	56.6	49.6	40.3
	120	50	97.5	85.4	23.4
	140	70	142.	124.3	16.1
	160	90	190.	166.3	12.03
	180	110	242.	212.	9.44
	200	130	298.5	261.5	7.65

Above figures involving waste of coal are based on 10,000 B. t. u. available per pound of coal, which is equivalent to a boiler efficiency of 70% using coal with an assumed heat value of about 14,000 B. t. u. per pound.

These figures are very conservative, as both the boiler efficiency and the heat value of the coal are high—a lesser boiler efficiency or inferior grade of coal would cause even a greater waste in pounds of fuel.

The figures are based also on continuous service, 24 hours per day.

## Minimum Thicknesses of Steam Pipe Insulation to be used for Given Character of Service

Steam Pressures	Steam Temperatures	Thickness of Insulation for Pipes Larger than 4" in Size	Thickness of Insulation for Pipes 2" to 4" in Size	Thickness of Insulation for Pipes ½" to 1½"
0 to 25 lbs.	212° to 267° F.	1" or Standard*	1" or Standard*	1" or Standard*
25 to 100 lbs.	267° to 338° F.	1½"	1½"	1" or Standard*
100 to 200 lbs.	338° to 388° F.	2" or D'ble Standard*	1½"	1" or Standard*
Higher Pressures } or Superheat }	{ 388° to 500° F. { 500° to 600° F.	2½" 3"	2" or D'ble Standard* 2½"	1½" 2" or D'ble Standard*

For higher temperatures obtain special recommendations.

\* Standard and Double Standard thickness apply to 85% Magnesia Insulation only—other thicknesses apply to all types of insulation.

It is always preferable to apply insulation greater than 1½-inch thickness in two or more layers with all joints broken or staggered.





## Data on Standard Full-Weight Wrought-Iron and Steel Pipe

Nominal Internal, In.	Diameter			Nominal Thickness, In.	Circumference		Transverse Areas			Length of Pipe per Sq. Ft. of		Length of Pipe Containing 1 Cu. Ft., Ft.	Nominal Weight per Ft., Lbs.	No. of Threads per In. of Screw	Area External Surface per Lineal Foot, Sq. Ft.
	Actual External, In.	Approx. Internal, In.			External, In.	Internal, In.	External, Sq. In.	Internal, Sq. In.	Metal, Sq. In.	External Surface, Ft.	Internal Surface, Ft.				
3/8	0.405	0.27	0.068	1.27	0.85	0.13	0.06	0.07	9.44	14.15	2513.00	0.24	27	.106	
1/4	0.540	0.36	0.083	1.70	1.14	0.23	0.10	0.12	7.08	10.49	1383.30	0.42	18	.141	
5/8	0.675	0.49	0.091	2.12	1.55	0.36	0.19	0.17	5.66	7.76	751.20	0.57	18	.177	
1/2	0.840	0.62	0.109	2.63	1.95	0.55	0.30	0.25	4.55	6.15	472.40	0.85	14	.220	
3/4	1.050	0.82	0.113	3.30	2.59	0.87	0.53	0.33	3.64	4.64	270.00	1.13	14	.275	
1	1.315	1.05	0.134	4.13	3.29	1.36	0.86	0.50	2.90	3.65	166.90	1.68	11 1/2	.344	
1 1/4	1.660	1.38	0.140	5.22	4.34	2.16	1.50	0.67	2.30	2.77	96.25	2.27	11 1/2	.435	
1 1/2	1.900	1.61	0.145	5.97	5.06	2.84	2.04	0.80	2.01	2.37	70.66	2.72	11 1/2	.498	
2	2.375	2.07	0.154	7.46	6.49	4.43	3.36	1.07	1.61	1.85	42.91	3.65	11 1/2	.622	
2 1/2	2.875	2.47	0.204	9.03	7.75	6.49	4.78	1.71	1.33	1.55	30.10	5.79	8	.753	
3	3.500	3.07	0.217	11.00	9.63	9.62	7.39	2.24	1.09	1.25	19.50	7.57	8	.917	
3 1/2	4.000	3.55	0.226	12.57	11.15	12.57	9.89	2.68	0.96	1.08	14.57	9.11	8	1.047	
4	4.500	4.03	0.237	14.14	12.65	15.90	12.73	3.18	0.85	0.95	11.31	10.79	8	1.178	
4 1/2	5.000	4.51	0.246	15.71	14.16	19.64	15.96	3.68	0.76	0.85	9.02	12.54	8	1.309	
5	5.563	5.05	0.259	17.48	15.85	24.31	19.99	4.32	0.69	0.76	7.20	14.62	8	1.456	
6	6.625	6.07	0.280	20.81	19.05	34.47	28.89	5.59	0.58	0.63	4.98	18.97	8	1.734	
7	7.625	7.02	0.301	23.96	22.06	45.66	38.74	6.92	0.50	0.54	3.72	23.54	8	1.996	
8	8.625	8.07	0.276	27.10	25.35	58.43	51.15	7.28	0.44	0.47	2.82	24.69	8	2.257	
8	8.625	7.98	0.322	27.10	25.07	58.43	50.02	8.41	0.44	0.48	2.88	28.55	8	2.257	
9	9.625	8.94	0.344	30.24	28.08	72.76	62.72	10.04	0.40	0.43	2.29	33.91	8	2.519	
10	10.750	10.19	0.278	33.77	32.01	90.76	81.55	9.21	0.36	0.37	1.76	31.20	8	2.817	
10	10.750	10.14	0.306	33.77	31.86	90.76	80.75	10.01	0.36	0.38	1.78	34.24	8	2.817	
10	10.750	10.02	0.366	33.77	31.47	90.76	78.82	11.94	0.36	0.38	1.82	40.48	8	2.817	
11	11.750	11.00	0.375	36.91	34.56	108.43	95.03	13.40	0.33	0.35	1.51	45.56	8	3.073	
12	12.750	12.09	0.328	40.06	37.98	127.68	114.80	12.88	0.30	0.32	1.25	43.77	8	3.337	
12	12.750	12.00	0.375	40.06	37.70	127.68	113.10	14.59	0.30	0.32	1.27	49.56	8	3.338	
14OD	14.000	13.25	0.375	43.96	41.60	153.86	137.81	16.05	0.27	0.29	1.04	54.57	8	3.663	
15OD	15.000	14.25	0.375	47.10	44.70	176.62	159.39	17.23	0.25	0.27	0.90	58.57	8	3.927	
16OD	16.000	15.25	0.375	50.27	47.90	200.96	182.55	18.41	0.24	0.25	0.75	62.58	8	4.188	

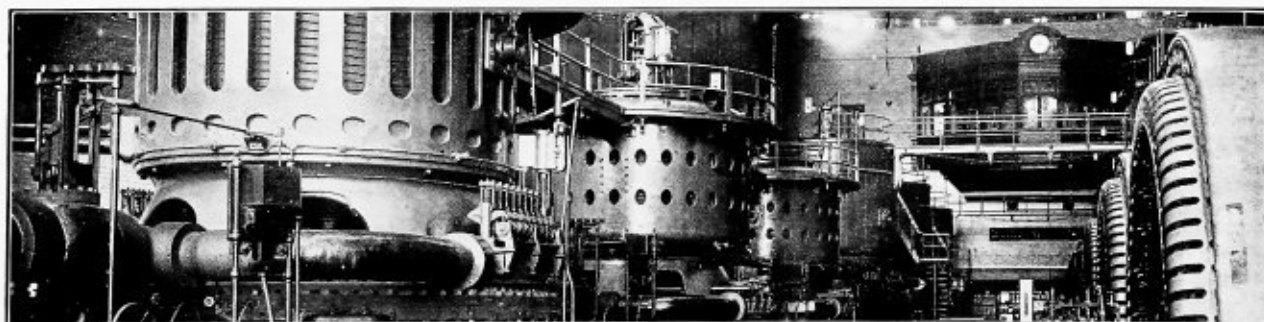



## Total Radiation Areas and Equivalents of Standard Flanged Fittings

Including the accompanying flanges bolted to the fitting

Figures in columns under "Area" give surface areas in SQUARE FEET.  
Figures in columns under "Pipe Lengths" give the number of feet of pipe which has an area equivalent to the area of the fittings.

Standard Pipe Size I. D.	Flanged Coupling		90° Ell		Long Radius Ell		Tee		Cross	
	Area	Pipe Lengths	Area	Pipe Lengths	Area	Pipe Lengths	Area	Pipe Lengths	Area	Pipe Lengths
1"	.320	.93	.795	2.31	.892	2.59	1.235	3.59	1.622	4.72
1 1/4"	.383	.88	.957	2.20	1.084	2.49	1.481	3.40	1.943	4.47
1 1/2"	.477	.95	1.174	2.35	1.337	2.68	1.815	3.64	2.38	4.78
2"	.672	1.08	1.65	2.65	1.84	2.96	2.54	4.08	3.32	5.34
2 1/2"	.841	1.12	2.09	2.78	2.32	3.08	3.21	4.26	4.19	5.56
3"	.945	1.03	2.38	2.60	2.68	2.93	3.66	3.99	4.77	5.70
3 1/2"	1.122	1.07	2.98	2.85	3.28	3.13	4.48	4.28	5.83	5.56
4"	1.344	1.14	3.53	2.90	3.96	3.36	5.41	4.59	7.03	5.97
4 1/2"	1.474	1.13	3.95	3.01	4.43	3.38	6.07	4.63	7.87	6.01
5"	1.622	1.11	4.44	3.049	5.00	3.43	6.81	4.67	8.82	6.06
6"	1.82	1.049	5.13	2.95	5.99	3.45	7.84	4.53	10.08	5.81
7"	2.17	1.097	6.17	3.09	7.38	3.697	9.37	4.69	12.00	6.01
8"	2.41	1.067	6.98	3.09	8.56	3.79	10.55	4.67	13.44	5.96
9"	3.00	1.19	8.71	3.457	10.57	4.20	13.18	5.23	16.78	6.66
10"	3.43	1.22	10.18	3.61	12.35	4.38	15.41	4.47	19.58	6.95
12"	4.41	1.32	13.08	3.92	16.35	4.90	19.67	5.89	24.87	7.45
14" O.D.	5.39	1.465	16.38	4.47	20.17	5.47	24.81	6.78	31.48	8.60
15" O.D.	6.18	1.572	18.50	4.72	22.92	5.83	27.91	7.10	35.48	9.04
16" O.D.	6.69	1.60	20.17	4.82	25.41	6.07	30.32	7.23	38.34	9.15

## Total Radiation Areas and Equivalents of Extra Heavy Flanged Fittings

Including the accompanying flanges bolted to the fitting

Figures in columns under "Area" give surface areas in SQUARE FEET.  
Figures in columns under "Pipe Lengths" give the number of feet of pipe which has an area equivalent to the area of the fittings.

Standard Pipe Size I. D.	Flanged Coupling		90° Ell		Long Radius Ell		Tee		Cross	
	Area	Pipe Lengths	Area	Pipe Lengths	Area	Pipe Lengths	Area	Pipe Lengths	Area	Pipe Lengths
1"	.438	1.273	1.015	2.95	1.083	3.148	1.575	4.578	2.07	6.02
1 1/4"	.510	1.172	1.098	2.524	1.340	3.08	1.925	4.425	2.53	5.816
1 1/2"	.727	1.459	1.332	2.674	1.874	3.762	2.68	5.381	3.54	7.108
2"	.848	1.363	2.01	3.23	2.16	3.473	3.09	4.968	4.06	6.528
2 1/2"	1.107	1.463	2.57	3.41	2.76	3.665	4.05	5.378	5.17	6.865
3"	1.484	1.619	3.49	3.807	3.74	4.08	5.33	5.815	6.95	7.582
3 1/2"	1.644	1.57	3.96	3.782	4.28	4.087	6.04	5.768	7.89	7.535
4"	1.914	1.624	4.64	3.938	4.99	4.236	7.07	6.001	9.24	7.843
4 1/2"	2.04	1.558	5.02	3.834	5.46	4.170	7.72	5.897	10.07	7.692
5"	2.18	1.497	5.47	3.756	6.02	4.134	8.52	5.851	10.97	7.534
6"	2.78	1.603	6.99	4.031	7.76	4.475	10.64	6.136	13.75	7.929
7"	3.46	1.733	8.62	4.318	9.73	4.874	12.33	6.177	16.83	8.431
8"	3.77	1.670	9.76	4.324	11.09	4.913	14.74	6.531	18.97	8.405
9"	4.44	1.762	11.44	4.541	13.17	5.228	17.23	6.84	22.10	8.773
10"	5.20	1.846	13.58	4.82	15.60	5.538	20.41	7.245	26.26	9.322
12"	6.71	2.01	17.73	5.31	18.76	5.622	26.65	7.987	34.11	10.222
14" O.D.	8.30	2.26	22.31	6.08	25.70	7.02	33.63	9.18	43.15	11.75
15" O.D.	9.52	2.43	25.28	6.43	29.34	7.47	38.04	9.68	48.79	12.4
16" O.D.	10.05	2.4	27.18	6.475	31.73	7.575	40.94	9.775	52.35	12.5



## Table of Decimal Equivalents

OF MILLIMETERS AND FRACTIONS OF MILLIMETERS

OF 8THS, 16THS, 32DS, AND 64THS OF AN INCH

$\frac{1}{100} = .0003937$

mm. Inches	mm. Inches	mm. Inches	mm. Inches
$\frac{1}{100} = .00079$	$\frac{29}{100} = .03071$	27 = 1.06299	64 = 2.51968
$\frac{2}{100} = .00157$	$\frac{30}{100} = .03150$	28 = 1.10236	65 = 2.55905
$\frac{3}{100} = .00236$	$\frac{31}{100} = .03228$	29 = 1.14173	66 = 2.59842
$\frac{4}{100} = .00315$	$\frac{32}{100} = .03307$	30 = 1.18110	67 = 2.63779
$\frac{5}{100} = .00394$	$\frac{33}{100} = .03386$	31 = 1.22047	68 = 2.67716
$\frac{6}{100} = .00472$	$\frac{34}{100} = .03465$	32 = 1.25984	69 = 2.71653
$\frac{7}{100} = .00551$	$\frac{35}{100} = .03543$	33 = 1.29921	70 = 2.75590
$\frac{8}{100} = .00630$	$\frac{36}{100} = .03622$	34 = 1.33858	71 = 2.79527
$\frac{9}{100} = .00709$	$\frac{37}{100} = .03701$	35 = 1.37795	72 = 2.83464
$\frac{10}{100} = .00787$	$\frac{38}{100} = .03780$	36 = 1.41732	73 = 2.87401
$\frac{11}{100} = .00866$	$\frac{39}{100} = .03858$	37 = 1.45669	74 = 2.91338
$\frac{12}{100} = .00945$	1 = .03937	38 = 1.49606	75 = 2.95275
$\frac{13}{100} = .01024$	2 = .07874	39 = 1.53543	76 = 2.99212
$\frac{14}{100} = .01102$	3 = .11811	40 = 1.57480	77 = 3.03149
$\frac{15}{100} = .01181$	4 = .15748	41 = 1.61417	78 = 3.07086
$\frac{16}{100} = .01260$	5 = .19685	42 = 1.65354	79 = 3.11023
$\frac{17}{100} = .01339$	6 = .23622	43 = 1.69291	80 = 3.14960
$\frac{18}{100} = .01417$	7 = .27559	44 = 1.73228	81 = 3.18897
$\frac{19}{100} = .01496$	8 = .31496	45 = 1.77165	82 = 3.22834
$\frac{20}{100} = .01575$	9 = .35433	46 = 1.81102	83 = 3.26771
$\frac{21}{100} = .01654$	10 = .39370	47 = 1.85039	84 = 3.30708
$\frac{22}{100} = .01732$	11 = .43307	48 = 1.88976	85 = 3.34645
$\frac{23}{100} = .01811$	12 = .47244	49 = 1.92913	86 = 3.38582
$\frac{24}{100} = .01890$	13 = .51181	50 = 1.96850	87 = 3.42519
$\frac{25}{100} = .01969$	14 = .55118	51 = 2.00787	88 = 3.46456
$\frac{26}{100} = .02047$	15 = .59055	52 = 2.04724	89 = 3.50393
$\frac{27}{100} = .02126$	16 = .62992	53 = 2.08661	90 = 3.54330
$\frac{28}{100} = .02205$	17 = .66929	54 = 2.12598	91 = 3.58267
$\frac{29}{100} = .02283$	18 = .70866	55 = 2.16535	92 = 3.62204
$\frac{30}{100} = .02362$	19 = .74803	56 = 2.20472	93 = 3.66141
$\frac{31}{100} = .02441$	20 = .78740	57 = 2.24409	94 = 3.70078
$\frac{32}{100} = .02520$	21 = .82677	58 = 2.28346	95 = 3.74015
$\frac{33}{100} = .02598$	22 = .86614	59 = 2.32283	96 = 3.77952
$\frac{34}{100} = .02677$	23 = .90551	60 = 2.36220	97 = 3.81889
$\frac{35}{100} = .02756$	24 = .94488	61 = 2.40157	98 = 3.85826
$\frac{36}{100} = .02835$	25 = .98425	62 = 2.44094	99 = 3.89763
$\frac{37}{100} = .02913$	26 = 1.02362	63 = 2.48031	100 = 3.93700

10 mm. = 1 Centimeter = 0.3937 inches  
 10 cm. = 1 Decimeter = 3.937 inches  
 10 dm. = 1 Meter = 39.37 inches  
 25.4 mm. = 1 English inch

<b>8ths</b>	$\frac{5}{32} = .15625$	$\frac{17}{64} = .265625$
$\frac{1}{8} = .125$	$\frac{7}{32} = .21875$	$\frac{19}{64} = .296875$
$\frac{1}{4} = .250$	$\frac{9}{32} = .28125$	$\frac{21}{64} = .328125$
$\frac{3}{8} = .375$	$\frac{11}{32} = .34375$	$\frac{23}{64} = .359375$
$\frac{1}{2} = .500$	$\frac{13}{32} = .40625$	$\frac{25}{64} = .390625$
$\frac{5}{8} = .625$	$\frac{15}{32} = .46875$	$\frac{27}{64} = .421875$
$\frac{3}{4} = .750$	$\frac{17}{32} = .53125$	$\frac{29}{64} = .453125$
$\frac{7}{8} = .875$	$\frac{19}{32} = .59375$	$\frac{31}{64} = .484375$
	$\frac{21}{32} = .65625$	$\frac{33}{64} = .515625$
	$\frac{23}{32} = .71875$	$\frac{35}{64} = .546875$
<b>16ths</b>	$\frac{25}{32} = .78125$	$\frac{37}{64} = .578125$
$\frac{1}{16} = .0625$	$\frac{27}{32} = .84375$	$\frac{39}{64} = .609375$
$\frac{3}{16} = .1875$	$\frac{29}{32} = .90625$	$\frac{41}{64} = .640625$
$\frac{5}{16} = .3125$	$\frac{31}{32} = .96875$	$\frac{43}{64} = .671875$
$\frac{7}{16} = .4375$		$\frac{45}{64} = .703125$
$\frac{9}{16} = .5625$	<b>64ths</b>	$\frac{47}{64} = .734375$
$\frac{11}{16} = .6875$	$\frac{1}{64} = .015625$	$\frac{49}{64} = .765625$
$\frac{13}{16} = .8125$	$\frac{3}{64} = .046875$	$\frac{51}{64} = .796875$
$\frac{15}{16} = .9375$	$\frac{5}{64} = .078125$	$\frac{53}{64} = .828125$
	$\frac{7}{64} = .109375$	$\frac{55}{64} = .859375$
	$\frac{9}{64} = .140625$	$\frac{57}{64} = .890625$
<b>32ds</b>	$\frac{11}{64} = .171875$	$\frac{59}{64} = .921875$
$\frac{1}{32} = .03125$	$\frac{13}{64} = .203125$	$\frac{61}{64} = .953125$
$\frac{3}{32} = .09375$	$\frac{15}{64} = .234375$	$\frac{63}{64} = .984375$

## Circumferences and Areas of Circles

Diam.	Circ.	Area	Diam.	Circ.	Area	Diam.	Circ.	Area	Diam.	Circ.	Area	Diam.	Circ.	Area	Diam.	Circ.	Area
3	9.424	7.068	7	21.99	38.484	11	34.55	95.033	15	47.12	176.71	19	59.69	283.52			
3 1/8	9.817	7.669	7 1/8	22.38	39.871	11 1/8	34.95	97.205	15 1/8	47.51	179.67	19 1/8	60.08	287.27			
3 1/4	10.21	8.295	7 1/4	22.77	41.282	11 1/4	35.34	99.402	15 1/4	47.90	182.72	19 1/4	60.47	291.03			
3 3/8	10.60	8.946	7 3/8	23.16	42.718	11 3/8	35.73	101.62	15 3/8	48.30	185.66	19 3/8	60.86	294.83			
3 1/2	10.99	9.621	7 1/2	23.56	44.178	11 1/2	36.12	103.86	15 1/2	48.69	188.69	19 1/2	61.26	298.64			
3 5/8	11.38	10.320	7 5/8	23.95	45.663	11 5/8	36.52	106.13	15 5/8	49.08	191.74	19 5/8	61.65	302.48			
3 3/4	11.78	11.044	7 3/4	24.34	47.173	11 3/4	36.91	108.43	15 3/4	49.48	194.82	19 3/4	62.04	306.35			
3 7/8	12.17	11.793	7 7/8	24.74	48.707	11 7/8	37.30	110.75	15 7/8	49.87	197.93	19 7/8	62.43	310.24			
4	12.56	12.566	8	25.13	50.265	12	37.69	113.09	16	50.26	201.06	20	62.83	314.16			
4 1/8	12.95	13.364	8 1/8	25.52	51.848	12 1/8	38.09	115.46	16 1/8	50.65	204.21	20 1/8	63.22	318.09			
4 1/4	13.35	14.186	8 1/4	25.91	53.456	12 1/4	38.48	117.85	16 1/4	51.05	207.39	20 1/4	63.61	322.06			
4 3/8	13.74	15.033	8 3/8	26.31	55.088	12 3/8	38.87	120.27	16 3/8	51.44	210.59	20 3/8	64.01	326.05			
4 1/2	14.13	15.904	8 1/2	26.70	56.745	12 1/2	39.27	122.71	16 1/2	51.83	213.82	20 1/2	64.40	330.06			
4 5/8	14.52	16.800	8 5/8	27.09	58.426	12 5/8	39.66	125.18	16 5/8	52.22	217.07	20 5/8	64.79	334.10			
4 3/4	14.92	17.720	8 3/4	27.48	60.132	12 3/4	40.05	127.67	16 3/4	52.62	220.35	20 3/4	65.18	338.16			
4 7/8	15.31	18.665	8 7/8	27.88	61.862	12 7/8	40.44	130.19	16 7/8	53.01	223.65	20 7/8	65.58	342.25			
5	15.70	19.635	9	28.27	63.617	13	40.84	132.73	17	53.40	226.98	21	65.97	346.36			
5 1/8	16.10	20.629	9 1/8	28.66	65.396	13 1/8	41.23	135.29	17 1/8	53.79	230.33	21 1/8	66.36	350.49			
5 1/4	16.49	21.647	9 1/4	29.05	67.200	13 1/4	41.62	137.88	17 1/4	54.19	233.70	21 1/4	66.75	354.65			
5 3/8	16.88	22.690	9 3/8	29.45	69.029	13 3/8	42.01	140.50	17 3/8	54.58	237.10	21 3/8	67.15	358.84			
5 1/2	17.27	23.758	9 1/2	29.84	70.882	13 1/2	42.41	143.13	17 1/2	54.97	240.52	21 1/2	67.54	363.05			
5 5/8	17.67	24.850	9 5/8	30.23	72.759	13 5/8	42.80	145.80	17 5/8	55.37	243.97	21 5/8	67.93	367.28			
5 3/4	18.06	25.967	9 3/4	30.63	74.662	13 3/4	43.19	148.48	17 3/4	55.76	247.45	21 3/4	68.32	371.54			
5 7/8	18.45	27.108	9 7/8	31.02	76.588	13 7/8	43.58	151.20	17 7/8	56.16	250.94	21 7/8	68.72	375.82			
6	18.84	28.274	10	31.41	78.539	14	43.98	153.93	18	56.54	254.46	22	69.11	380.13			
6 1/8	19.24	29.464	10 1/8	31.80	80.515	14 1/8	44.37	156.69	18 1/8	56.94	258.01	22 1/8	69.50	384.46			
6 1/4	19.63	30.679	10 1/4	32.20	82.516	14 1/4	44.76	159.48	18 1/4	57.33	261.58	22 1/4	69.90	388.82			
6 3/8	20.02	31.919	10 3/8	32.59	84.540	14 3/8	45.16	162.29	18 3/8	57.72	265.18	22 3/8	70.29	393.20			
6 1/2	20.42	33.183	10 1/2	32.98	86.590	14 1/2	45.55	165.13	18 1/2	58.11	268.80	22 1/2	70.68	397.60			
6 5/8	20.81	34.471	10 5/8	33.37	88.664	14 5/8	45.94	167.98	18 5/8	58.51	272.44	22 5/8	71.07	402.03			
6 3/4	21.20	35.784	10 3/4	33.77	90.762	14 3/4	46.33	170.87	18 3/4	58.90	276.11	22 3/4	71.47	406.49			
6 7/8	21.57	37.122	10 7/8	34.16	92.885	14 7/8	46.73	173.78	18 7/8	59.29	279.81	22 7/8	71.86	410.97			





# Johns-Manville Service to Industry



## Circumferences and Areas of Circles

Diam.	Circ.	Area	Diam.	Circ.	Area	Diam.	Circ.	Area	Diam.	Circ.	Area	Diam.	Circ.	Area	Diam.	Circ.	Area
23	72.25	415.47	34	106.8	907.92	45	141.3	1590.4	56	175.9	2463.0	67	210.4	3525.6	78	245.9	4808.1
	72.64	420.00		107.2	914.61		141.7	1599.2		176.3	2474.0		210.9	3538.8		246.3	4821.9
	73.04	424.55		107.5	921.32		142.1	1608.1		176.7	2485.0		211.2	3552.0		246.7	4835.8
	73.43	429.13		107.9	928.06		142.5	1617.0		177.1	2496.1		211.6	3565.2		247.1	4849.7
	73.82	433.73		108.3	934.82		142.9	1625.9		177.5	2507.1		212.0	3578.4		247.5	4863.6
	74.21	438.30		108.7	941.60		143.3	1634.9		177.8	2518.2		212.4	3591.7		247.9	4877.5
	74.61	443.01		109.1	948.41		143.7	1643.8		178.2	2529.4		212.8	3605.0		248.3	4891.4
	75.00	447.69		109.5	955.25		144.1	1652.8		178.6	2540.5		213.2	3618.3		248.7	4905.3
24	75.39	452.39	35	109.9	962.11	46	144.5	1661.9	57	179.0	2551.7	68	213.6	3631.6	79	249.1	4919.2
	75.79	457.11		110.3	968.99		144.9	1670.9		179.4	2562.9		214.0	3645.0		249.5	4933.1
	76.18	461.86		110.7	975.90		145.2	1680.0		179.8	2574.1		214.4	3658.4		249.9	4947.0
	76.57	466.63		111.1	982.84		145.6	1689.1		180.2	2585.4		214.8	3671.8		250.3	4960.9
	76.96	471.43		111.5	989.80		146.0	1698.2		180.6	2596.7		215.2	3685.2		250.7	4974.8
	77.36	476.25		111.9	996.78		146.4	1707.3		181.0	2608.0		215.6	3698.7		251.1	4988.7
	77.75	481.10		112.3	1003.78		146.8	1716.5		181.4	2619.3		216.0	3712.2		251.5	5002.6
	78.14	485.97		112.7	1010.8		147.2	1725.7		181.8	2630.7		216.4	3725.7		251.9	5016.5
25	78.54	490.87	36	113.0	1017.8	47	147.6	1734.0	58	182.2	2642.0	69	216.8	3739.2	80	252.3	5030.4
	78.93	495.79		113.4	1024.9		148.0	1744.1		182.6	2653.4		217.2	3752.8		252.7	5044.3
	79.32	500.74		113.8	1032.0		148.4	1754.3		183.0	2664.8		217.6	3766.4		253.1	5058.2
	79.71	505.71		114.2	1039.1		148.8	1764.7		183.4	2676.3		218.0	3780.0		253.5	5072.1
	80.10	510.70		114.6	1046.3		149.2	1775.2		183.8	2687.8		218.4	3793.6		253.9	5086.0
	80.50	515.72		115.0	1053.5		149.6	1785.8		184.2	2699.3		218.8	3807.3		254.3	5100.0
	80.89	520.70		115.4	1060.7		150.0	1796.5		184.6	2710.8		219.2	3821.0		254.7	5113.9
	81.28	525.83		115.8	1067.9		150.4	1800.1		185.0	2722.4		219.6	3834.7		255.1	5127.8
26	81.68	530.93	37	116.2	1075.2	48	150.7	1809.5	59	185.3	2733.9	70	219.9	3848.4	81	255.5	5141.7
	82.07	536.04		116.6	1082.4		151.1	1818.1		185.7	2745.5		220.3	3862.2		255.9	5155.6
	82.46	541.18		117.0	1089.7		151.5	1828.4		186.1	2757.1		220.7	3875.9		256.3	5169.5
	82.85	546.35		117.4	1097.1		151.9	1837.9		186.5	2768.8		221.1	3889.8		256.7	5183.4
	83.25	551.54		117.8	1104.4		152.3	1847.4		186.9	2780.5		221.5	3903.6		257.1	5197.3
	83.64	556.76		118.2	1111.8		152.7	1856.9		187.3	2792.2		221.9	3917.4		257.5	5211.2
	84.03	562.00		118.6	1119.2		153.1	1866.5		187.7	2803.9		222.3	3931.3		257.9	5225.1
	84.43	567.26		118.9	1126.6		153.5	1876.1		188.1	2815.6		222.7	3945.2		258.3	5239.0
27	84.82	572.55	38	119.3	1134.1	49	153.9	1885.7	60	188.4	2827.4	71	223.0	3959.2	82	258.7	5252.9
	85.21	577.87		119.7	1141.5		154.3	1895.3		188.8	2839.2		223.4	3973.1		259.1	5266.8
	85.60	583.20		120.1	1149.0		154.7	1905.0		189.2	2851.0		223.8	3987.1		259.5	5280.7
	86.00	588.57		120.5	1156.6		155.1	1914.7		189.6	2862.8		224.2	4001.1		259.9	5294.6
	86.39	593.95		120.9	1164.1		155.5	1924.4		190.0	2874.7		224.6	4015.1		260.3	5308.5
	86.78	599.37		121.3	1171.7		155.9	1934.1		190.4	2886.6		225.0	4029.2		260.7	5322.4
	87.17	604.80		121.7	1179.3		156.2	1943.9		190.8	2898.5		225.4	4043.2		261.1	5336.3
	87.57	610.26		122.1	1186.9		156.6	1953.6		191.2	2910.5		225.8	4057.3		261.5	5350.2
28	87.96	615.75	39	122.5	1194.5	50	157.0	1963.5	61	191.6	2922.4	72	226.1	4071.5	83	261.9	5364.1
	88.35	621.26		122.9	1202.2		157.4	1973.3		192.0	2934.4		226.5	4085.6		262.3	5378.0
	88.75	626.79		123.3	1209.9		157.8	1983.1		192.4	2946.4		226.9	4099.8		262.7	5391.9
	89.14	632.35		123.7	1217.6		158.2	1993.0		192.8	2958.5		227.3	4114.0		263.1	5405.8
	89.53	637.94		124.0	1225.4		158.6	2002.9		193.2	2970.5		227.7	4128.2		263.5	5419.7
	89.92	643.54		124.4	1233.1		159.0	2012.8		193.6	2982.6		228.1	4142.5		263.9	5433.6
	90.32	649.18		124.8	1240.9		159.4	2022.8		193.9	2994.7		228.5	4156.7		264.3	5447.5
	90.71	654.83		125.2	1248.7		159.8	2032.8		194.3	3006.9		228.9	4171.0		264.7	5461.4
29	91.10	660.52	40	125.6	1256.6	51	160.2	2042.8	62	194.7	3019.0	73	229.3	4185.3	84	265.1	5475.3
	91.49	666.22		126.0	1264.5		160.6	2052.8		195.1	3031.2		229.7	4199.7		265.5	5489.2
	91.89	671.95		126.4	1272.3		161.0	2062.9		195.5	3043.4		230.1	4214.1		265.9	5503.1
	92.28	677.71		126.8	1280.3		161.3	2072.9		195.9	3055.7		230.5	4228.5		266.3	5517.0
	92.67	683.49		127.2	1288.2		161.7	2083.0		196.3	3067.9		230.9	4242.9		266.7	5530.9
	93.06	689.29		127.6	1296.2		162.1	2093.2		196.7	3080.2		231.3	4257.3		267.1	5544.8
	93.46	695.12		128.0	1304.2		162.5	2103.3		197.1	3092.5		231.7	4271.8		267.5	5558.7
	93.85	700.98		128.4	1312.2		162.9	2113.5		197.5	3104.8		232.0	4286.3		267.9	5572.6
30	94.24	706.86	41	128.8	1320.2	52	163.3	2123.7	63	197.9	3117.2	74	232.4	4300.8	85	268.3	5586.5
	94.64	712.76		129.1	1328.3		163.7	2133.9		198.3	3129.6		232.8	4315.3		268.7	5600.4
	95.03	718.69		129.5	1336.4		164.1	2144.1		198.7	3142.0		233.2	4329.9		269.1	5614.3
	95.42	724.64		129.9	1344.5		164.5	2154.4		199.0	3154.4		233.6	4344.5		269.5	5628.2
	95.81	730.61		130.3	1352.6		164.9	2164.7		199.4	3166.9		234.0	4359.1		269.9	5642.1
	96.21	736.61		130.7	1360.8		165.3	2175.0		199.8	3179.4		234.4	4373.8		270.3	5656.0
	96.60	742.64		131.1	1369.0		165.7	2185.4		200.2	3191.9		234.8	4388.4		270.7	5669.9
	96.99	748.69		131.5	1377.2		166.1	2195.7		200.6	3204.4		235.2	4403.1		271.1	5683.8
31	97.38	754.76	42	131.9	1385.4	53	166.5	2206.1	64	201.0	3216.9	75	235.6	4417.8	86	271.5	5697.7
	97.78	760.86		132.3	1393.7		166.8	2216.6		201.4	3229.5		236.0	4432.6		271.9	5711.6
	98.17	766.99		132.7	1401.9		167.2	2227.0		201.8	3242.1		236.4	4447.3		272.3	5725.5
	98.56	773.14		133.1	1410.2		167.6	2237.5		202.2	3254.8		236.				





## Fahrenheit and Centigrade Conversion Table

Cent.	Fahr.	Cent.	Fahr.	Cent.	Fahr.	Cent.	Fahr.	Cent.	Fahr.	Cent.	Fahr.	Cent.	Fahr.
0	32	230	446	460	860	690	1274	920	1688	1150	2102	1380	2516
5	41	235	455	465	869	695	1283	925	1697	1155	2111	1385	2525
10	50	240	464	470	878	700	1292	930	1706	1160	2120	1390	2534
15	59	245	473	475	887	705	1301	935	1715	1165	2129	1395	2543
20	68	250	482	480	896	710	1310	940	1724	1170	2138	1400	2552
25	77	255	491	485	905	715	1319	945	1733	1175	2147	1405	2561
30	86	260	500	490	914	720	1328	950	1742	1180	2156	1410	2570
35	95	265	509	495	923	725	1337	955	1751	1185	2165	1415	2579
40	104	270	518	500	932	730	1346	960	1760	1190	2174	1420	2588
45	113	275	527	505	941	735	1355	965	1769	1195	2183	1425	2597
50	122	280	536	510	950	740	1364	970	1778	1200	2192	1430	2606
55	131	285	545	515	959	745	1373	975	1787	1205	2201	1435	2615
60	140	290	554	520	968	750	1382	980	1796	1210	2210	1440	2624
65	149	295	563	525	977	755	1391	985	1805	1215	2219	1445	2633
70	158	300	572	530	986	760	1400	990	1814	1220	2228	1450	2642
75	167	305	581	535	995	765	1409	995	1823	1225	2237	1455	2651
80	176	310	590	540	1004	770	1418	1000	1832	1230	2246	1460	2660
85	185	315	599	545	1013	775	1427	1005	1841	1235	2255	1465	2669
90	194	320	608	550	1022	780	1436	1010	1850	1240	2264	1470	2678
95	203	325	617	555	1031	785	1445	1015	1859	1245	2273	1475	2687
100	212	330	626	560	1040	790	1454	1020	1868	1250	2282	1480	2696
105	221	335	635	565	1049	795	1463	1025	1877	1255	2291	1485	2705
110	230	340	644	570	1058	800	1472	1030	1886	1260	2300	1490	2714
115	239	345	653	575	1067	805	1481	1035	1895	1265	2309	1495	2723
120	248	350	662	580	1076	810	1490	1040	1904	1270	2318	1500	2732
125	257	355	671	585	1085	815	1499	1045	1913	1275	2327	1505	2741
130	266	360	680	590	1094	820	1508	1050	1922	1280	2336	1510	2750
135	275	365	689	595	1103	825	1517	1055	1931	1285	2345	1515	2759
140	284	370	698	600	1112	830	1526	1060	1940	1290	2354	1520	2768
145	293	375	707	605	1121	835	1535	1065	1949	1295	2363	1525	2777
150	302	380	716	610	1130	840	1544	1070	1958	1300	2372	1530	2786
155	311	385	725	615	1139	845	1553	1075	1967	1305	2381	1535	2795
160	320	390	734	620	1148	850	1562	1080	1976	1310	2390	1540	2804
165	329	395	743	625	1157	855	1571	1085	1985	1315	2399	1545	2813
170	338	400	752	630	1166	860	1580	1090	1994	1320	2408	1550	2822
175	347	405	761	635	1175	865	1589	1095	2003	1325	2417	1555	2831
180	356	410	770	640	1184	870	1598	1100	2012	1330	2426	1560	2840
185	365	415	779	645	1193	875	1607	1105	2021	1335	2435	1565	2849
190	374	420	788	650	1202	880	1616	1110	2030	1340	2444	1570	2858
195	383	425	797	655	1211	885	1625	1115	2039	1345	2453	1575	2867
200	392	430	806	660	1220	890	1634	1120	2048	1350	2462	1580	2876
205	401	435	815	665	1229	895	1643	1125	2057	1355	2471	1585	2885
210	410	440	824	670	1238	900	1652	1130	2066	1360	2480	1590	2894
215	419	445	833	675	1247	905	1661	1135	2075	1365	2489	1595	2903
220	428	450	842	680	1256	910	1670	1140	2084	1370	2498	1600	2912
225	437	455	851	685	1265	915	1679	1145	2093	1375	2507		

## Metric Conversion Table

Millimetres  $\times .03937$  = inches.  
 Millimetres  $\div 25.4$  = inches.  
 Centimetres  $\times .3937$  = inches.  
 Centimetres  $\div 2.54$  = inches.  
 Metres  $\times 39.37$  = inches. (Act of Congress.)  
 Metres  $\times 3.281$  = feet.  
 Metres  $\times 1.094$  = yards.  
 Kilometres  $\times .621$  = miles.  
 Kilometres  $\div 1.6093$  = miles.  
 Kilometres  $\times 3280.8693$  = feet.  
 Square Millimetres  $\times .00155$  = sq. inches.  
 Square Millimetres  $\div 645.1$  = sq. inches.  
 Square Centimetres  $\times .155$  = sq. inches.  
 Square Centimetres  $\div 6.451$  = sq. inches.  
 Square Metres  $\times 10.764$  = sq. feet.  
 Square Kilometres  $\times 247.1$  = acres.  
 Hectare  $\times 2.471$  = acres.  
 Cubic Centimetres  $\div 16.383$  = cubic inches.  
 Cubic Centimetres  $\div 3.69$  = fl. drams (U.S.P.)

Cubic Centimetres  $\div 29.57$  = fluid ounce (U.S.P.)  
 Cubic Metres  $\times 35.315$  = cubic feet.  
 Cubic Metres  $\times 1.308$  = cubic yards.  
 Cubic Metres  $\times 264.2$  = gallons (231 cubic inches.)  
 Litres  $\times 61.022$  = cu. in. (Act of Congress.)  
 Litres  $\times 33.84$  = fluid ounces (U.S.P.)  
 Litres  $\times 264.2$  = gallons (231 cu. in.)  
 Litres  $\div 3.78$  = gallons (231 cu. in.)  
 Litres  $\div 28.316$  = cubic feet.  
 Hectolitres  $\times 3.531$  = cubic feet.  
 Hectolitres  $\times 2.84$  = bushels (2150.42 cu. inches.)  
 Hectolitres  $\times .131$  = cubic yards.  
 Hectolitres  $\div 26.42$  = gallons (231 cu. in.)  
 Grammes  $\times 15.432$  = grains. (Act of Congress.)  
 Grammes  $\times 981$  = dynes.  
 Grammes (water)  $\div 29.57$  = fluid ounces.  
 Grammes  $\div 28.35$  = ounces avoirdupois.

Grammes per cu. cent.  $\div 27.7$  = lbs. per cubic inches.  
 Joule  $\times .7373$  = foot pounds.  
 Kilo-grammes  $\times 2.2046$  = pounds.  
 Kilo-grammes  $\times 35.3$  = oz. avoirdupois.  
 Kilo-grammes  $\div 907.2$  = tons (2,000 lbs.)  
 Kilo-grammes per sq. cent.  $\times 14.223$  = lbs. per sq. in.  
 Kilo-gram-metres  $\times 7.233$  = foot lbs.  
 Kilo-gr. per Metre  $\times .672$  = lbs. per foot.  
 Kilo-gr. per Cu. Metre  $\times .062$  = lbs. per cubic feet.  
 Tonneau  $\times 1.1023$  = tons (2,000 lbs.)  
 Kilo-Watts  $\times 1.34$  = Horse Power.  
 Watts  $\div 746$  = Horse Power.  
 Watts  $\times .7373$  = foot pounds per second.  
 Calorie  $\times 3.968$  = B. t. u.  
 Cheval vapeur  $\div .9863$  = Horse Power.  
 (Centigrade  $\times 1.8$ )  $\div 32$  = degree Fahr.  
 Gravity Paris = 980.94 centimetres per sec.





	Page		Page
Block & Sheet Insulation,		Clutch Facings, Asbestos Woven.....	236
—Asbestocel, Flexible Roll Form.....	41	Coating,	
—Asbestocel, Improved .....	40	—Aertite Boiler Wall .....	57
—Asbesto-Sponge Felted .....	35	—Liquid Waterproof .....	199
—Asbestos Fire Felt .....	37	Coil Packing, Mogul .....	67
—85% Magnesia .....	36	Cold Water Paint .....	168
—List Prices .....	45	"Colorblende" and Standard Asbestos Shingles	
—Millboard, Asbestos .....	43	(rigid) .....	149
—Thermo Fire-Felt .....	38	Combination Air Pump Packing, Special.....	74
—Vitribestos .....	39	Combination Steam Hammer Packing, Universal...	69
—Vitro Fire Felt .....	38	Compound, Leak-no Metallic .....	58
—Weights and Standard Sizes.....	45	Compound, Rubber Splicing.....	219
Board (Roll and Paper, Asbestos).....	43	Concrete Primer .....	197
Boat Deck Covering.....	194	Conduit, Orangeburg Fibre .....	208
Boiler Manhole Gaskets, Kearsarge Asbestos-Metallic	82	Conversion Table, Centigrade & Fahrenheit.....	253
Boiler Wall Coating, Aertite .....	57	Conversion Table, Metric .....	253
Booth, Motion Picture Projection, Asbestos Wood..	230	Cord, Asbestos .....	72
Brake Elocks, Asbestos-Metallic .....	88	Correction of Architectural Acoustics.....	202
Brake Lining, Non-Burn Asbestos, Automotive....	234	Corrugated Asbestos Protected Metal Roofing and	
Brake Lining, Non-Burn Asbestos, Industrial.....	91	Siding .....	141
Brine and Ammonia, Insulation Built-up.....	23	Corrugated Asbestos Roofing and Siding, Transite.	133
Brooks Brand (White Top) Asbestos Ready-to-lay		Covering, Third Rail.....	223
Roofing .....	127	Cups, Moulded Packing.....	85
Building Insulation (Housline) .....	177	Cut Stone Backing .....	199
Built-up Asbestos Roofing .....	112		
Built-up Brine and Ammonia Insulation.....	23	<b>D</b>	
Built-up Hair Felt Insulation.....	42	Dampproofing.....	198
<b>C</b>		Data on Wrought Iron and Steel Pipe.....	249
Cable Insulation, Niagrite Asbestoment Fireproof..	220	Decimals, Equivalents of .....	251
<b>CEMENTS</b>		Disc Clutch Facings, Asbestos Friction.....	237
—Asbestos Insulating, Nos. 302, 400, 352, 364....	46	Double Coated Asbestos Ready-to-lay Roofing,	
—Asphalt Roofing .....	167	Flexstone .....	126
—Asphalt Waterproofing .....	197	Duct, Underfloor, Orangeburg System of.....	213
—85% Magnesia, Insulating .....	46	Duplex Rod & Plunger Packing.....	66
—Ferrotite .....	58		
—Fire Felt, No. 302 .....	46	<b>E</b>	
—Fireite Asbestos Furnace .....	58	Ebony Asbestos Wood .....	204
—H-O Pipe Joint .....	58	—Technical data .....	205
—Insulating .....	46	Ebony Moulded Insulation.....	206
—Pickling Tank .....	198	Efficiencies,	
—Plastic No. 29 .....	53	—Asbesto-Sponge Felted Pipe Insulation.....	13-14
—Plastic P R-15 .....	53	—Asbesto-Sponge Felted Sheets and Blocks.....	44
—Refractory or High Temperature,		—85% Magnesia Blocks .....	44
Nos. 20, 25, 30, 31, 32, 33 & 35.....	47-56	—85% Magnesia Sectional Pipe Insulation.....	17-18
—Retort.....	53	—Thermo Fire Felt, Sheets & Blocks.....	44
—Self-Healing, Waterproofing .....	198	Efficiency Tables, How to Use.....	243
—Special.....	54	85% Magnesia Blocks, Weights of.....	45
—Super-refractory, Nos. 33 & 35.....	51	85% Magnesia Sectional Pipe Insulation.....	15
—Waterproofing, Asphalt .....	197	85% Magnesia Sheet & Block Insulation.....	36
Centigrade and Fahrenheit Conversion Tables....	253	85% Magnesia Cement.....	46
Chemical Fire Extinguisher, Success.....	231	Electrobestos .....	224
Circles, Areas and Circumferences .....	251	Enamel, Asbestos Fibrous .....	167
Cloth, Asbestos .....	229	Equivalents and Radiation Areas of Standard	
Clothing, Asbestos .....	226	Flanged Fittings .....	250
Clutch Facings, Asbestos Friction Disc.....	237	Equivalents of Decimals, Table of.....	251
		Expansion Joint Filler .....	198





	Page
Express Brand, Wool Felt Pipe Insulation.....	27
Extinguishers, Fire, Success Chemical.....	231

## F

Fabric, Asphalt Saturated .....	197
Facings, Asbestos Friction Disc Clutch.....	237
Facings, Clutch, Asbestos Woven.....	235
Fahrenheit and Centigrade Conversion Tables.....	253
Fasteners, Roofing, Pyramid Kap.....	127
Felt, Asbestos Slater's.....	157
Felt, Asbestos Waterproofing.....	197
Felt, Hair, Standard .....	42
Ferrotite Cement .....	58
Fibre Conduit, Orangeburg .....	208
Fibroid Asbestos Paper Tape.....	221
Fibrous Enamel, Asbestos .....	167
Filler, Expansion Joint .....	198
Fire Extinguisher,	
—Success Chemical .....	231
—Success Non-Freezing .....	231
Fire Felt,	
—Asbestos Insulating Cement, No. 302.....	45
—Asbestos Pipe Insulation .....	22
—Asbestos Roll, Plain or Indented.....	41
—Asbestos Sheet & Block Insulation.....	37
—Thermo Sheets and Blocks.....	38
—Vitro, Sheets and Blocks .....	38
Fireite Asbestos Furnace Cement .....	58
Fireproof Cable Insulation, Niagrite.....	220
Flange Joint Gaskets, Service and Seigelite.....	84
Flanged Fittings, Radiation areas and equivalents..	250
Flexstone Asbestos Ready-to-lay Roofing .....	125
Flexstone Asbestos Shingles (Slate Surface).....	161
Flexstone Double Coated Asbestos Ready-to-lay Roofing .....	125
Flooring,	
—Industrial .....	186
Ford Cars, Transmission Lining for.....	235
400, No. Insulating Cement.....	46
Friction Blocks, Asbesto-Metallic.....	88
Friction Disc Clutch Facings, Asbestos.....	237
Friction Tapes .....	218
Furnace Cement, Fireite Asbestos .....	58

## G

Gasketing, Kearsarge Asbesto-Metallic, Tubular ..	83
Gasketing, Tape, Kearsarge Asbesto-Metallic.....	83
Gaskets,	
—Air Pump, Top Head and Bottom Head.....	86
—Jointless Tube Plate, Kearsarge.....	82
—Kearsarge Asbesto-Metallic Boiler Manhole, Handhole & Tube Plate .....	82
—Service and Seigelite Flange Joint.....	84
—Top Head and Bottom Head.....	86

## H

	Page
Hair Felt Insulation,	
—Built-up, pipe .....	42
—Standard .....	42
—For Buildings (Housline) .....	177
Handhole, Manhole and Tube Plate Gaskets, Kearsarge Asbesto-Metallic .....	82
Heat Losses from Uninsulated Hot Surfaces.....	248
Heat Losses per Lineal Foot of Bare Pipes, etc.....	244
High Temperature or Refractory Cements, Nos. 20, 25, 30, 31, 32, 33 and 35.....	47-56
High Temperature Packing, Asbestos.....	73
H-O Pipe Joint Cement.....	58
Hot Surfaces, Heat Losses from Uninsulated.....	248
How to Use Tables of Insulation Efficiencies.....	243

## I

Industrial Brake Band Lining, Non-Burn Asbestos..	91
Industrial Flooring .....	185
Insulated Roof Decks.....	114
INSULATING CEMENTS	
—Asbestos, Nos. 302, 352, 364 and 400, & Fire Felt	46
—85% Magnesia .....	46
Insulation, Moulded Ebony.....	206
Insulation, Object of .....	9
Insulation Efficiency Tables, How to use.....	243
INSULATIONS	
—Anti-Sweat Sectional Pipe .....	25
—Asbesto-Sponge Felted Sectional Pipe .....	10
—Asbesto-Sponge Felted Sheets & Blocks.....	35
—Asbestocel Flexible Roll Form.....	41
—Asbestos Fire Felt Roll.....	41
—Asbestos Fire Felt, Sectional.....	22
—Asbestos Fire Felt Sheets and Blocks.....	37
—Asbestos Paper & Roll Board .....	43
—Building Insulation (Housline).....	177
—Built-up Brine and Ammonia.....	23
—Built-up Hair Felt .....	42
—85% Magnesia Blocks .....	36
—85% Magnesia Sectional Pipe .....	15
—Improved Asbestocel, Fine Corrugated, Sec- tional .....	20
—Improved Asbestocel Sectional Pipe .....	19
—Improved Asbestocel, Sheets and Blocks.....	40
—List Prices, Sectional.....	28
—List Prices, Sheets and Blocks.....	45
—Minimum thicknesses for various services.....	248
—Niagrite Fireproof Cable Insulation.....	220
—Roll Fire Felt .....	41
—Standard Hair Felt Insulation.....	42
—Steam Pipe Insulation, Minimum Thicknesses for various services .....	248
—Thermo Fire Felt Sheet & Block Insulation....	38





	Page		Page
<b>INSULATIONS (Continued)</b>			
—Underground System of Insulation .....	29	Losses from Bare Pipes and Other Bare Surfaces, etc. ....	244
—Vitribestos Sheet & Block.....	39	Losses, Heat, from Uninsulated Hot Surfaces.....	248
—Vitre Fire Felt .....	38	<b>M</b>	
—Weights of Sectional Pipe Insulations.....	28	Magnesia, 85% Block Insulation .....	36
—Weights of Sheet & Block Insulations.....	45	Magnesia, 85% Cement .....	46
—Wool Felt Insulation .....	27	Magnesia, 85% Sectional Pipe Insulation.....	15
—Zero Sectional Pipe Insulation.....	27	Manhole, Handhole and Tube Plate, Gaskets, Kearsarge Asbesto-Metallic .....	82
Insulator, Housline .....	177	Metallic Compound, Leak-No.....	58
Integral Waterproofing .....	196	Metric Conversion Table .....	253
Iron and Steel Pipe, Data on.....	249	Millboard, Asbestos Sheet .....	43
Iron Preservative.....	168	Millimeters and Fractions of Millimeters, Decimal Equivalents of .....	251
<b>J</b>			
Jewett Ring Packing.....	70	Mineral Surfaced Roofing, Asbestos Ready-to-lay, Flexstone .....	126
Jewett Ring Packing, Automotive.....	240	Minimum Thicknesses of Steam Pipe Insulation...	249
Joint Filler, Expansion .....	198	Mobilene Sheet Packing .....	81
Joint, Flange Gaskets, Service and Seigelite.....	84	Mogul Coil Packing.....	67
Joint Runner, Asbestos Lead.....	232	Mogul Twisted Packing, Automotive.....	240
Jointless Tube Plate Gaskets, Kearsarge.....	82	Monolithic Baffle Walls .....	55
Junior Steam Traps.....	97	Motion Picture Projection Booth, Asbestos Wood..	230
<b>K</b>			
Kaps, Pyramid .....	127	Moulded Air Pump Packing .....	75
Kearsarge Air Pump Packing.....	65	Moulded Ebony Insulation.....	206
Kearsarge Ammonia, No. 15.....	65	Moulded Packing Cups.....	85
Kearsarge Asbesto-Metallic Gasketing Tape.....	83	<b>N</b>	
Kearsarge Asbesto-Metallic Manhole, Handhole and Tube Plate Gaskets .....	82	New York Air Pumps, Packing for.....	76
Kearsarge Asbesto-Metallic Sheet Packing.....	81	Niagrite and Asbestoment Fireproof Cable Insulation .....	220
Kearsarge Asbesto-Metallic Tubular Gasketing.....	83	Non-Burn Asbestos Automotive Brake Lining.....	234
Kearsarge Jointless Tube Plate Gaskets.....	82	Non-Burn Asbestos Brake Lining, Industrial.....	91
Kearsarge Locomotive Throttle Packing.....	77	Non-Freezing Fire Extinguishers, Success.....	231
Kearsarge Rod Packing .....	64	<b>O</b>	
Keystone Air Pump Packing.....	75	Orangeburg Fibre Conduit .....	208
<b>L</b>			
Lead Joint Runner, Asbestos .....	232	Orangeburg Underfloor Duct System .....	213
Leak-no Metallic Compound .....	58	<b>P</b>	
Liberty Red Rubber Sheet Packing.....	81	<b>PACKINGS</b>	
Lining, Asbestos Stove, Phoenix.....	58	—Air Pump, Kearsarge .....	65
Lining, Non-Burn Asbestos, Automotive.....	234	—Air Pump, Keystone .....	75
Lining, Non-Burn Asbestos Brake Band, Industrial	91	—Air Pump, Moulded .....	75
Lining, Transmission, for Ford cars.....	235	—Air Pump, Special Combination .....	74
Liquid Waterproof Coating .....	199	—Air Pump, Top Head and Bottom Head Gaskets.....	86
Listing, Asbestos.....	222	—Asbesto-Metallic Gasketing Tape .....	83
<b>LIST PRICES</b>			
—Ebony Asbestos Wood .....	205	—Asbesto-Metallic Gaskets, Kearsarge .....	82
—Non-Burn Asbestos Automotive Brake Lining	234	—Asbesto-Metallic Sheet, Kearsarge .....	81
—Non-Burn Asbestos Industrial Brake Band Lining.....	91	—Asbesto-Metallic Tubular, Kearsarge .....	83
—Orangeburg Fibre Conduit.....	211	—Asbestos Braided Rope .....	72
—Sectional Pipe Insulation .....	28	—Asbestos Wick .....	72
—Sheet & Block Insulation .....	45	—Coil, Mogul .....	67
—Transite Asbestos Wood .....	207	—Combination Air Pump, Special.....	74
Locomotive Throttle Packing, Kearsarge.....	77	—Duplex Rod & Plunger.....	66
Losses due to Steam Leakage .....	247	—Gasketing, Asbesto-Metallic Tape .....	83



	Page		Page
<b>PACKINGS (Continued)</b>		<b>Pilot Brand (Rag-felt) Roofing</b> .....	165
—Gasketing, Asbesto-Metallic Tubular .....	83	<b>Pipe Insulation Efficiency Tables, How to Use</b> ...	243
—Gaskets, Kearsarge, Asbesto-Metallic .....	82	<b>PIPE INSULATIONS</b>	
—Gaskets, Kearsarge, Jointless .....	82	—Anti-Sweat Sectional .....	25
—High Temperature .....	73	—Asbesto-Sponge Felted Sectional .....	10
—Jewett Ring .....	70	—Asbestos Fire Felt, Sectional .....	22
—Jewett Rings, Automotive .....	240	—Built-up Brine and Ammonia .....	23
—Kearsarge Air Pump .....	65	—85% Magnesia Sectional .....	15
—Kearsarge Asbesto-Metallic Boiler, Manhole, Handhole & Tube Plate Gaskets .....	82	—Fire Felt Sectional .....	22
—Kearsarge Asbesto-Metallic Gasketing Tape .....	83	—Improved Asbestocel Fine Corrugated, Sectional .....	20
—Kearsarge Asbesto-Metallic Gasketing, Tubular .....	83	—Improved Asbestocel, Sectional .....	19
—Kearsarge Asbesto-Metallic Gaskets, Jointless .....	82	—List Prices .....	28
—Kearsarge Asbesto-Metallic Sheet Packing .....	81	—Minimum Thicknesses of, for Various Services .....	248
—Kearsarge Rod Packing .....	64	—Underground System of .....	29
—Kearsarge Rod Packing, for Ammonia .....	65	—Weights of Sectional .....	28
—Keystone Air Pump .....	75	—Wool Felt, Sectional .....	27
—Liberty Red Rubber Sheet .....	81	—Zero, Sectional .....	27
—Locomotive Throttle, Kearsarge .....	77	<b>Pipe, Data on Wrought Iron and Steel</b> .....	249
—Mobilene Sheet .....	81	<b>Pipe Joint Cement, H-O</b> .....	58
—Mogul Coil .....	67	<b>Piston Packing, Universal</b> .....	68
—Mogul Twisted, Automotive .....	240	<b>Plunger &amp; Rod Packing</b>	
—Moulded Air Pump .....	75	—Duplex .....	66
—Moulded Packing Cups .....	85	—Kearsarge .....	64
—Piston, Universal .....	68	—Universal .....	71
—Plunger & Rod, Duplex .....	66	<b>Preservative, Iron</b> .....	168
—Plunger & Rod, Universal .....	71	<b>Price List, Non-Burn Asbestos Brake Band Lining, Industrial</b> .....	91-92
—Pump Packing Recommendations .....	78	—Orangeburg Fibre Conduit .....	211
—Pump Valves Moulded, No. 206 .....	86	—Sectional Pipe Insulations .....	28
—Pump Valves Rubber .....	86	—and Weights, Ebony Asbestos Wood .....	205
—Red Rubber Sheet, Liberty .....	81	—and Weights, Sheet and Block Insulations .....	45
—Rod & Plunger, Duplex .....	65	—and Weights, Transite Asbestos Wood .....	207
—Rod & Plunger, Universal .....	71	<b>Primer, Concrete</b> .....	197
—Rod, Kearsarge .....	64	<b>Projection Booth, Motion Picture, Asbestos Wood</b> .....	230
—Rope & Wick .....	72	<b>Pump Packing Recommendations</b> .....	78
—Rubber Pump Valves .....	85	<b>Pump Valves, Rubber</b> .....	86
—Sea Ring .....	60	—Moulded, No. 206 .....	86
—Seigelite Gaskets, Style No. 712 .....	84	<b>Putty, Asbestos Roof</b> .....	168
—Seigelite Sheet (Automotive) .....	239	<b>Putty, Bituminous</b> .....	198
—Seigelite Sheet, Style No. 711 .....	80	<b>Pyramid Kaps, Roofing Fasteners</b> .....	127
—Service Gaskets, Style No. 61 .....	84		
—Service Sheet (Automotive) .....	238	<b>R</b>	
—Service Sheet, Style No. 60 .....	79	<b>Radiation Areas and Equivalents of Flanged Fittings</b> .....	250
—Special Combination Air Pump .....	74	<b>Radiator Trap</b> .....	98
—Union Washers .....	86	<b>Rag-Felt Ready-to-lay Roofings &amp; Shingles</b> .....	165
—Universal Combination Steam Hammer .....	69	<b>Rail Covering (Third Rail)</b> .....	223
—Universal Piston .....	68	<b>READY-TO-LAY ASBESTOS ROOFINGS</b>	
—Universal Rod & Plunger .....	71	—Flexstone (smooth or slate surfaced) .....	125
—Valves, Pump, Moulded, No. 206 .....	86	—White Top .....	127
—Valves, Pump, Rubber .....	86	<b>Red Rubber Sheet Packing, Liberty</b> .....	81
—Wick & Rope .....	72	<b>Refractory Cements, Nos. 20, 26, 30, 31, 32, 33 and 35</b> .....	47-56
<b>Paint, Cold Water</b> .....	168	—Plastic No. 15 .....	53
<b>Paper &amp; Roll Board, Asbestos</b> .....	43	—Plastic No. 29 .....	53
<b>Paper Tape, Armature Asbestos</b> .....	221	—Retort .....	53
<b>Paper Tape, Fibroid Asbestos</b> .....	221	—Special .....	54
<b>Phoenix Asbestos Stove Lining</b> .....	58	<b>Registration, Roof</b> .....	110
<b>Pickling Tank Cement</b> .....	198		







	Page		Page
Steam Leakage, Losses due to.....	247	Twisted Mogul Automotive Packing.....	240
Steam Pipe Insulation, Minimum Thicknesses of..	248	<b>U</b>	
Steam Tables (Marks') .....	244	Underfloor Duct System, Orangeburg.....	213
Steam Traps .....	94	Underground System of Insulation.....	29
Steel and Wrought Iron Pipe, Data on.....	249	Underwriters Approval of Roofings.....	103
Stone Backing, Cut .....	199	Uninsulated Hot Surfaces, Losses from.....	248
Story of Asbestos .....	6	Union Washers .....	86
Stove Lining, Phoenix Asbestos.....	58	Universal Piston Packing.....	68
Strip Shingles, Flexstone Asbestos.....	162	—Combination Steam Hammer Packing.....	69
Strip Shingles, Slatekote (Rag-felt).....	166	—Rod and Plunger.....	71
Success Fire Extinguisher, Automatic Type.....	231	<b>V</b>	
Success Fire Extinguisher, Non-Freezing .....	231	Valves, Rubber Pump.....	86
Super-Refractory Cements, Nos. 33 and 35.....	51	—Moulded, No. 206.....	86
<b>T</b>			
Table of Data on Wrought Iron and Steel Pipe....	249	Ventilators, Transite Asbestos Wood.....	175
—Decimal Equivalents .....	251	Vitribestos Sheets and Blocks.....	39
—Fahrenheit and Centigrade Conversions.....	253	Vitro Fire Felt Sheets and Blocks.....	38
—Losses due to Steam Leakage.....	247	Volume Meter .....	100
—Losses from Bare Surfaces.....	244	Volume of Water at Various Pressures.....	248
—Metric Conversion .....	253	<b>W</b>	
—Steam .....	244	Wall Coating, Boiler, Aertite.....	57
Tank Cement, Pickling.....	198	Wall, Monolithic Baffle .....	55
Tape, Armature Asbestos.....	221	Wall Siding, Asbestoside .....	130
Tape, Automotive.....	239	Washers, Union .....	86
Tape, Fibroid Asbestos Paper.....	221	Waterproof Coating, Liquid .....	199
Tape, Friction .....	218	Waterproofing.....	196
Tape, Kearsarge Asbesto-Metallic Gasketing.....	83	—Cement, Asphalt .....	197
Technical Data, Refractory Cements.....	54	—Felt, Asbestos .....	197
Temperature Conversion Tables.....	253	—Self-Healing .....	198
Test on Roofing, Underwriters.....	103	Water Volume at Various Pressures .....	248
Thermo Fire Felt Sheets and Blocks.....	38	Weights and List Prices	
—Efficiencies of .....	44	—Ebony Asbestos Wood .....	205
—List Prices .....	45	—Sectional Pipe Insulation .....	28
Thickness of Steam Pipe Insulation, Minimum....	248	—Sheet & Block Insulation.....	45
Third Rail Covering .....	223	—Transite Asbestos Wood.....	207
Throttle Packing, Kearsarge .....	77	Westinghouse Air Pumps, Packing for.....	76
Top Head and Bottom Head Gaskets for Air Pumps	86	White Top Asbestos Ready-to-lay Roofing.....	127
Transite Asbestos Wood		Wick and Rope Packing, Asbestos.....	72
—Roofing (corrugated).....	133	Wood, Asbestos, Motion Picture Projection Booth.	230
—Ventilators .....	175	Wood, Ebony Asbestos .....	204
Transite Asbestos Wood (flat)		Wood, Transite Asbestos (flat).....	170
—Caps and Stacks .....	175	—for Electrical purposes .....	207
—Building Purposes.....	170	—Stacks and Caps .....	175
—Electrical Purposes.....	207	—Ventilators .....	175
—List Prices.....	207	Wool Felt Sectional Pipe Insulation.....	27
Transite Corrugated Asbestos Roofing & Siding..	133	Woven Clutch Facings, Asbestos.....	235
Transmission Lining for Ford cars.....	235	Wrought Iron and Steel Pipe, Data on.....	249
Traps, Junior Steam .....	97	<b>Y</b>	
Traps, Radiator.....	98	Yarns, Asbestos.....	229
Traps, Steam .....	94	<b>Z</b>	
Tube Plate Gaskets, Kearsarge Asbesto-Metallic..	82	Zero Sectional Pipe Insulation.....	27
—Kearsarge Jointless .....	82		
Tubing, Asbestos Braided .....	219		
Tubular Gasketing, Kearsarge Asbesto-Metallic..	83		
Twisted Asbestos Rope Packing.....	72		









CARNEGIE LIBRARY OF PITTSBURGH



3 1812 04075 5374

