

Labor Saving Looms

Third Edition
1907

presented by
Draper Company
Hopedale, Mass.

CARNEGIE LIBRARY
PITTSBURGH, PA.

CARNEGIE LIBRARY
PITTSBURGH, PA.



DRAPER COMPANY WORKS AT HOPEDALE, MASS., U. S. A.

PITTSBURGH, PA.
LABOR-SAVING LOOMS.

(THIRD EDITION.)

A BRIEF TREATISE ON

PLAIN WEAVING

AND THE

RECENT IMPROVEMENTS IN
THAT LINE WITH SPECIAL
REFERENCE TO THE . . .

NORTHROP LOOMS

MANUFACTURED BY

DRAPER COMPANY,

HOPEDALE, MASS.,

U. S. A.

1907

409

COPYRIGHT 1907,
BY DRAPER COMPANY.

WRITTEN AND COMPILED BY
GEORGE OTIS DRAPER,
SECRETARY OF DRAPER COMPANY.

PRINTED BY
MILFORD JOURNAL CO., MILFORD, MASS.

PREFACE.

In view of the time taken in preparation and the necessary lapse between editions, it is impossible for a catalogue of this nature to always keep pace with the improvements which we introduce. While this is the third edition of *Labor Saving Looms*, it is our sixth regular loom catalogue, there having been three with other titles, the first of which appeared in April, 1895. This early issue was so optimistic in spirit, as to create a certain degree of amusement amongst those who failed to foresee the possibilities in automatic weaving. Now that its early assertions can be viewed in the light of historic fact, they are found to be comparatively modest and unassuming. The inventions have proved fully as important as anticipated. They have won emphatic recognition in foreign countries, and have been largely responsible for the upbuilding of the textile industry in one great section of our own country. These catalogues have had enormous editions, considering there are only about one thousand weaving mills in this country where the Northrop loom could be used. We supply them on request to men occupying responsible positions under corporations directly connected with the weaving art.

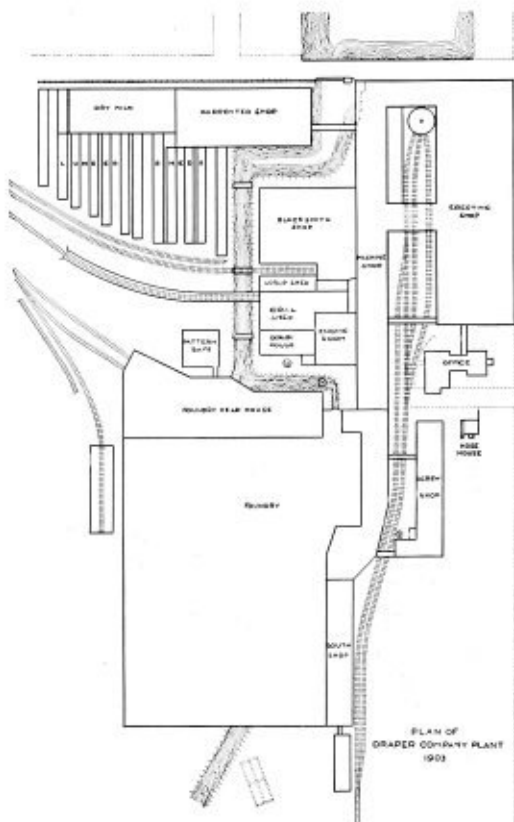

OUR HOPEDALE PLANT IN 1907.

Scale, 315 feet to the inch.

About 27 acres of floor space in all.

Telegrams are telephoned to us from the Milford office of the Western Union Co. If addressed to Hopedale they will reach us properly. Our long distance telephone call is Milford 26-13, 3 and 14.

OUR LOCATION.

Our works are situated in the country village of Hopedale, Mass., adjoining the large town of Milford, of which we were formerly a part. A straight line between Boston and New York would bisect us at a point less than thirty miles from the former city. While off of the main line of railroad we have branch connections to Boston from Milford via South Framingham on the Boston & Albany, (N. Y. Central) route and via Franklin to Boston on the N. Y., N. H. & H. route. **Purchase tickets at South Station, Boston, for Milford, Mass.,** and take hack from Milford to our office, or walk up Central Street, Milford, and take trolley to Hopedale. Parties coming from New York can change at South Framingham for Milford, if taking the B. & A. route on such trains as stop at South Framingham. Connections can be made by other trains and other routes through Boston, Providence or Worcester. The Grafton & Upton R. R. connects Hopedale with Worcester (19 miles), through North Grafton on the B. & A., and while it handles our freight at night, it runs a trolley service during the day. Connections are also made with trolley for Worcester at North Grafton. Providence (26 miles) connections are made either through Franklin by the N. Y., N. H. & H. route or by Woonsocket via Bellingham Junction on the Boston & Pascoag route, or by trolley either to Uxbridge or Woonsocket, where connections are made on the Providence and Worcester division of the N. Y., N. H. & H. R. R. Trolley cars passing our office run directly to South Framingham, (13 miles), in one direction and to Uxbridge (6 miles), Upton (5 miles), Grafton (10 miles) and North Grafton (13 miles) in the other, and connect at Milford with trolley lines to Woonsocket (13 miles), Franklin (10 miles), Medway (7 miles), Hopkinton (5 miles) and points beyond.

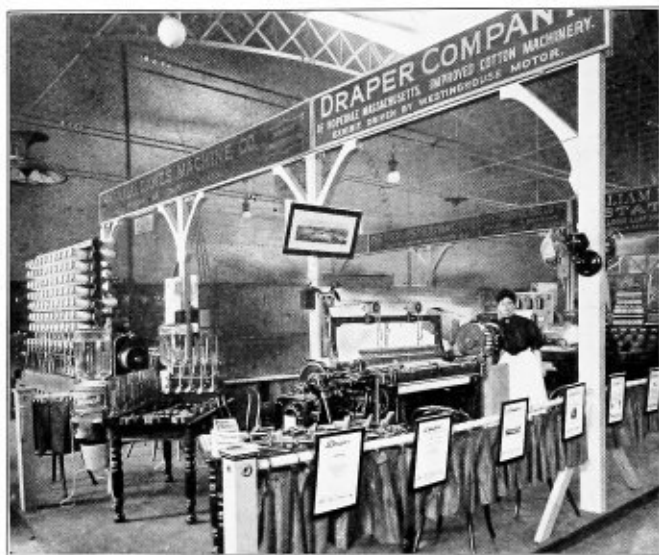

EXHIBIT OF DRAPER COMPANY
AT PHILADELPHIA, MAY, 1907.

This was in many respects, the most successful exhibition of Cotton Machinery ever presented since it attracted interested parties alone. The convention of the American Cotton Manufacturers' Association being held during the week brought practical men—possible purchasers, and the local city industries sent hundreds of intelligent visitors. The loom shown was weaving fine goods, 80s warp and 120s cop filling. So many doubts had been expressed as to the feasibility of cops for Northrop looms, we thought it well to show that such use was entirely practical.

CONCERNING DRAPER COMPANY.

In our complete catalogue, *Textile Texts*,—which does not, however, give a full detail of our loom department—we detail our own history at some length. For the benefit of those mainly interested in our loom and not perhaps acquainted with our former lines, it may be well to say that our business started with the invention of the self-acting loom temple by Ira Draper, in 1816, although the Drapers had been connected with the cloth industry ever since the name of “Draper” itself was originally chosen, or given. For over fifty years the business of the sons of Ira Draper and their associates, was largely confined to loom improvements, such as Patent temples, let-offs, shuttle guides, etc. The important spinning improvements of Carroll, Sawyer, Doyle, Rabbeth, and others, changed the main line of effort for a long period, the predecessors of Draper Company being primarily responsible for the introduction of high speed spinning.

Although looms are now our main product, we still continue the largest manufacturers of many other lines of cotton machinery. We sell spindles, spinning rings, separators and lever screws for spinning frames. We sell loom temples for all makes of loom, a complete line of twistors, warpers, balling machines, spoolers and reels. We make chain warpers, and introduce a special dyeing process. We manufacture bobbins for Northrop looms, apply filling changers and warp-stop-motions to certain other makes of loom; also shuttle-guards and thin-place preventers. We apply stop-motions to twistors of other makes, and sell bobbin-holders and spooler guides for spoolers of others' manufacture. We sell a new patent slasher comb, a patent dryer feed, oil cans, belt-hole guards, cotton-bale shears, etc. Send for our complete catalogue if interested in these lines.

FORMER LITERATURE ON THE NORTHROP LOOM.

1895.

Circular—*The Advent of the Northrop Loom*, issued April, 1895.

Essay, *The Present Development of the Northrop Loom*, delivered by George Otis Draper at the meeting of the N. E. Cotton Manufacturers' Association at Atlanta, Ga., Oct. 24, 1895. Printed in Vol. 59 of the Transactions.

1896.

Papers on *The Northrop Loom*, by F. M. Messenger, John H. Hines, H. D. Wheat, and discussion by Wm. F. Draper, Arthur H. Lowe, George F. Whittam and W. J. Kent, April 29, 1896, printed in Vol. 60 of the Transactions of the N. E. Cotton Manufacturers' Association.

Chapter in *Facts and Figures*, on the Northrop Loom, published by George Draper & Sons, in the spring of 1896.

Pamphlet—*The Looms of the South*, by F. B. de Berard, issued March, 1896, containing detail of savings from use of the Northrop Loom in Southern mills.

Speech of Hon. Wm. C. Lovering, published in the *Scientific American* of May 2, 1896, and other papers, containing pertinent reference to the loom.

Speech of Hon. Charles Warren Lippitt, published in the *Manufacturers' Record* of June 19, and papers generally throughout the country, giving the history of the Northrop loom development as illustrative of the educational influence of manufacturing.

Jubilee number of *The Dry Goods Economist*, contained an

article on American Textile Machinery in which the Northrop Loom was prominently featured.

1897.

Pamphlet—*Instructions for Running Northrop Looms*, issued by George Draper & Sons, January, 1897.

Pamphlet—*Instructions Pour la Conduite de Metiers Northrop*, issued by the Draper Company, 1897.

Circular—*Our Common Loom*, issued by the Draper Company, June, 1897.

Circular—*The Triumph of the Northrop Loom*, November, 1897.

Circular referring to the *Arkwright Club Report* issued December 28, 1897.

1898.

Circular—*Our Connection with the Art of Weaving*, issued by the Draper Company, April, 1898.

Circular—*Take-up Mechanism*, issued by the Draper Company, 1898.

Article—*Industrial investigations*, by Jacob Schoenhof, in *The Forum* for October, 1898. Referred to the great savings of the "Automatic loom," as affecting differences in cost of production.

1899.

Pamphlet—*Instructions for Running Northrop Looms*, (Revised Edition) issued by the Draper Company, January, 1899.

Pamphlet—*Machinery and Labor Displacement*, by George Gunton, issued by the Gunton Institute, containing pertinent reference to the Northrop Loom as a labor-saving invention.

1900.

Circular—*The Advance of the Northrop Loom*, January, 1900.

Pamphlet—*Factory Conditions in the South*, January 20,

1900, by George Gunton, in Gunton's Lecture Bureau course.

Paper on *Method of Cost Finding*, by Wm. G. Nichols, delivered at a meeting of the N. E. Cotton Manufacturers' Association at Boston, April 26, 1900. Printed in Vol. 68 of the Transactions.

Essay on *Improvements in American Cotton Machinery*, by George Otis Draper, delivered at a meeting of the Southern Cotton Spinners' Association at Charlotte, N. C., May 18, 1900. Printed in the Association records and various periodicals.

1901.

Chapter in *Textile Texts*, published by the Draper Company, spring of 1901.

Various articles in publication, *Cotton Chats*, started in July, 1901, and continued since.

Circular on *Important Discovery*, relating to method of spinning to prevent bunches in cloth, August, 1901.

1902.

Circular on *The Keene Drawing-in Machine*, January, 1902. References in Census Bulletin No. 215, June 28, 1902.

1903.

Circular on *The Northrop Loom*, issued by the British Northrop Loom Co., January, 1903.

Essay on *Continued Development of the Northrop Loom*, delivered by General Draper at a meeting of the N. E. Cotton Manufacturers' Association in Boston, April 23, 1903, printed in Vol. 74 of the Transactions.

Various references in a book, *The American Cotton Industry*, by T. M. Young, published by Charles Scribners' Sons, 1903.

Chapter on Northrop Loom in *Textile Texts*, second edition, issued December, 1903.

Essay on *The Development of the Northrop Loom*, delivered

before the Providence Society of Mechanical Engineers by George Otis Draper, printed in Providence Journal, Dec. 28, 1903, and other trade Journals.

1904.

Circular on *List of Northrop Looms Sold*, issued January, 1904.

Article on *Evolution of the Cotton Industry*, published in Gunton's Magazine for February, 1904.

Pamphlet—*Labor Saving Looms*, (First Edition).

Circular on *Long Bobbin Experiments*, issued May, 1904.

Article on *Is there a limit to rising wages?* published in Gunton's Magazine for July, 1904.

Reference in article on *The Cotton Industry* in the Cosmopolitan Magazine for July, 1904.

Address of President Herbert E. Walmsley to the New England Cotton Manufacturers' Association, published in Vol. 77 of the Transactions.

Article on *The Northrop Loom in England*, by H. P. Greg, published in British papers Dec. 31.

1905.

Varied press comment on labor conditions as affected by automatic weaving.

References in *Cotton Manufactures in Massachusetts and the Southern States*, published by the Massachusetts Bureau of Statistics of Labor, 1905.

Second Edition of *Labor Saving Looms*.

1906.

Chapter in *Reference Library of International Correspondence School of Scranton, Pa.*

Circular on *Stafford Company Bonds*, issued September, 1906.

1907.

Chapter in *The Mechanism of Weaving* Third Edition, by T. W. Fox.

Chapter on Northrop Looms in *Textile Texts*, Third Edition, issued in April.

Present Edition of *Labor Saving Looms*.

"There has been expended in experiments, in investigation and for patents some \$300,000. The result is a reduction of one-half in the cost of weaving cotton cloth. The cost of weaving constitutes one-half the cost of labor required to produce cotton cloth. Consequently the saving secured by the loom is approximately one-quarter of the labor of producing the cloth. Experts have estimated that in 1895, \$80,000,000 was paid for labor in the cotton manufacture in the United States. Assume that the improved loom had been thoroughly introduced, the saving secured thereby would have been approximately \$20,000,000. The interest on the national debt of the United States in 1892, the last year of Republican control, was \$22,893,000. The possible saving of the new loom, therefore, would be about seven-eighths of this interest."—[*Hon. Charles Warren Lippitt, ex-Governor of Rhode Island.*]

"Constant progress has been the watchword of the last quarter of a century, and will lead in the next, so near at hand. Mr. Draper puts the Northrop loom, the latest production of his model shop, into your mill today and starts it with amazing success, but while this pattern, the product of many years of hard work of the inventor, with the added talents of many mechanics, has been in course of construction, a new and better way has been devised to accomplish desired results or to overcome some slight defect obvious in your lot of looms. And you are told that in the next lot of looms built these defects will be remedied, and too late you regret that you had not waited before giving your order.

The difficulty, however, is inevitable. Evolution is constant in everything to which the mind devotes itself earnestly, honestly, and persistently—and each lot of looms turned out will naturally be superior in some respect to that which preceded it."—[*Pres. Frederick E. Clarke at Montreal meeting of the N. E. Cot. Man. Asso., Oct. 5, 1899.*]

"As regards the labor cost of production, we all know that the labor cost of weaving is in the neighborhood of one-half the total labor cost in the entire process of manufacturing cotton cloth. It is necessary, therefore, and admittedly so, in our efforts which must ever and always be unremitting in legitimately bringing down the cost of manufacture, to pay the closest attention to this particular department of cost, and, in this connection, it would appear pertinent to inquire whether or not we have in New England as a whole, taken sufficient advantage of the warp-stop motion, and of a certain wonderful, automatic, almost human, labor-

saving machine, invented and built right in our midst, known as the Northrop loom. I speak plainly. Or have we permitted our Southern friends, as a whole, to get the better of us in adopting this machine more readily than we ourselves have done? I fear many of us must admit that such is the case. Nothing is more certain than that it will have to be reckoned with and of which the least observant among us must be convinced. It behooves us, therefore, to see to it that we put our houses in order with as little delay as possible, and if there are any of us whose financial condition is such that we are unable to install this loom, we must either go to the wall or so rearrange our financial affairs so as to enable us to equip ourselves equal to the best in every particular. If there was ever a time in the history of the cotton trade when alone it was 'the survival of the fittest,' that time is right now. This phase of our inquiry, and the remedy, where remedy is called for and needed, is plainly apparent and will admit of no evasion or delay."—[*President Herbert E. Walmsley at meeting of N. E. Cot. Man. Assn., Sept. 21, 1904.*]

"The Northrop loom, by increasing the capacity of the operative 300 per cent., has brought the manufacture of cotton up to a point that is considered practically perfect. In its most highly developed form this loom now enables one man to do the work of a thousand men at the beginning of the cotton industry, working by hand."—[*From article on "Evolution of the Cotton Industry," in Gunton's Magazine for Feb., 1904.*]

"In New England today the price of weaving on the ordinary looms, with the last ten per cent. that has just been given, is nineteen and eight-tenths cents—say twenty cents—per cut, that is, for fifty yards. A new loom has been invented by which the weaver can mind about twice as many, and therefore the price per cut is reduced about one-half. These are what are called the Draper looms. . . . In the South they have hardly any other kind of looms; they have the best. I saw one woman minding twenty-four looms. . . . The price they pay for fifty yards in South Carolina is six and one-quarter cents. The operatives of course, even at this rate, are earning more than they ever earned before." *George Gunton.*

"So far as the equipment of the Southern mills in the matter of looms is concerned, they are certainly more advanced than any other part of the country, Massachusetts not by any means excepted. Nearly all the Southern mills are equipped with the Northrop loom, which is considered the most improved and supplied with the latest inventions. The great advantage, so far as the South is concerned, lies in the fact that one operative can attend to from 16 to 20 of these looms, and therefore the Southern mills look upon the Northrop as a means of salvation in their present shortage of help."—[*Annual Report Mass. Bureau of Statistics of Labor for 1905.*]

"With the exception of the Northrop loom, British subjects have been the world's benefactors in regard to textile machines."—[*Bulletin No. 63, Dept. Commerce & Labor.*]

“ . . . the Northrop loom is more and more being adopted for all single shuttle work.”

“A girl brought up in the lonely hill country of Tennessee or Alabama can run twenty Northrop looms in a very short time, as though she had been born and bred in the weaving shed.”—[*Report of Lancashire Private Cotton Investigation Commission.*]

“At the time of writing spool-changing devices are less numerous than shuttle-changers, but they are more extensively used, probably because it is less objectionable to change the contents of a shuttle than to change a shuttle, for shuttles are specially liable to injury during the changing operation; it is also more difficult to adjust shuttle boxes to many shuttles than to one.”—[*T. W. Fox in The Mechanism of Weaving.*]

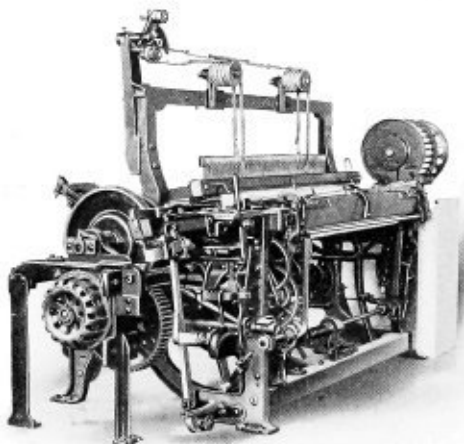

NORTHROP LOOM AS EXHIBITED
AT PHILADELPHIA.



Spinners and Weavers of America

By Edward W. Perry

COPYRIGHT BY E. W. PERRY.

IN the beginning Dame Nature set a pattern as a weaver, for she wrapped snugly in brown cloth the spathes of the palms, and bandaged the stalks of the banana with a web, uncounted ages before men had wit to interweave stakes and bushes and poles to make fence and wall. This was long before men or women learned to twine twigs, reeds or grasses together to make mat or tent, or to weave the fibers from leaf or from stalk, or the hair from animal into blanket or sheet.

Mother Nature wove other cloth of threads closely laced, and hid it in the bark of the tuno tree; and to this hour her children who live the simple life in Central America cut from such trees long sheets of their bark; and women anchor these pieces to soak in the warm rivers there. Later those women pound that bark long and diligently, with carved hammers of stone and with clubs of rosewood or ebony or of other dense wood neatly carved. In time the pulp is beaten out, and the tough fibers become clean and soft, ready for bleaching on the hot sandbar by the river. When whitened enough, the blankets are adorned by designs done in red or brown, or black stains, and then are ready to make bed or hammock.

No one can truly say when or where man first began to weave cloth. Nor can any tell us surely whether this art spread from a common center, or was invented by many who dwelt in widely separated parts of the world. Ages would have been required to carry news of such invention around the world by the slow and infrequent journeyings of barbarous workmen from the native home of the invention to the far corners of the earth; but in primitive devices for spinning and for weaving there is, in regions separated by wide oceans, a sameness that is held by some men of science as proof that the art of making and using such devices must have come from a single source.

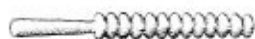

One such early device is the spindle-whorl that was used at least as early as the later stone age, say about the time when our grandfathers lived in villages perched on piles driven into Swiss lakes, or in stockaded

homes on the islands of Britain, and knew weaving and spinning as common household duties.



Centuries before the Spanish conquistador sailed into the Far West in search of the treasures of the Indies, Aztec and Maya, and doubtless many another mother of old American families, taught their girls to spin threads pulled from the leaves of the maguey, the long and silky fibers of the wild pineapple, and the cotton from the trees

which bore blossom and ripe boll at the same moment through all the months. And to do their spinning they used spindles and whorls that were almost identical in shape, as they were in the manner of their use, with the whorls of that far away stone age of Europe, when the lake dwellers of Switzerland twisted threads as they watched for the coming of the canoes that would bring fish for the dinner.

And similar whorls, patiently ground out of stone or moulded from clay, were used by the Muskokis and other Indians of our own Southern States for spinning the fibers of the wild hemp that grew, much higher than a man's head, in the fertile bottom lands and gave tough thread from which to weave carpets and blankets many a generation ago. But their work was as of yesterday, compared with that weaving of which shreds and patches, and perhaps older imprints in the earth, have been uncovered in the ancient mounds, discovered in long forgotten tombs, and found set out in the comparatively recent books of the pictured history of pre-Columbian America. For, long before the coming of Christian to the New World, fabrics that to the weavers must have seemed fine and beautiful, were spun and woven of the wool of the An-



des, and of other materials, as far to the north as California. How many ages must have passed after the invention of the weaver's art before the snowy raiment of the vestals of the Sun, and the royal robes of the Incas, children of the glowing God of Day and of Life, could be made.

Before Columbus set foot on this continent he saw the fruit of the loom of America; for when his little ship rounded to under the lee of the isle of Guanaja in 1502, he found there a big canoe loaded with goods of Yucatan. Among these were thick jackets of quilted cotton, used as armor to shield from thrust of spear, prick of arrow and blow from club, and wooden sword edged with jagged bits of volcanic glass.

That quilted cotton armor was almost identical in appearance with the jackets worn not long ago—maybe yesterday—by Chinese soldiers—which fact suggests that the making of such things may have been first taught in America by those missionaries who came from China to teach the lore of the gentle Buddha, five centuries before Christ came on earth, and nearly a thousand years before Columbus first saw the shores of the Western continent.

Before white men ravaged the empire of Peru the wool of the vicuna and the cotton gathered by the people of that great domain, were distributed among weavers whose occupation had come down to them through the centuries, from father to son, from mother to daughter. Confined to certain families, this work of spinning and of weaving developed great deftness, which was by observation, by precept and by practice developed into notable skill in using the simple devices they had with which to do their tasks.

But these people have learned little from their white conquerors, in all the four hundred years that have passed since civilization fell like a blight on all they held dear. To this day descendants of those olden Americans use the same old inventions, in the ancient way, to make goods of the same patterns that were made centuries ago. And to this day the Indian of the vast forests of the Amazon, the Carib of the seashore, the Waika of the Mosquito Coast, and the remnants of the Maya tribes of the mountain valleys spin coarse cords of bark or of

cotton, and of them weave their hammocks, or make blankets with looms that are little more than simple frames of poles. Sometimes these looms are but two posts planted firmly in the blackened earth that is the only floor of the leaf-thatched home of the weaver, and having two poles lashed horizontally across these uprights. The warp is wound, one continuous thread, around and round, over the upper and under the lower pole until the warp is as wide as the fabric is to be.

Instead of a harness, a thin stick is used to separate the threads of the warp, and the thread of the wool or filling is thrust across the web by a shuttle that is often little more than a long, smooth stick, cleft at one end to hold the end of the filling.

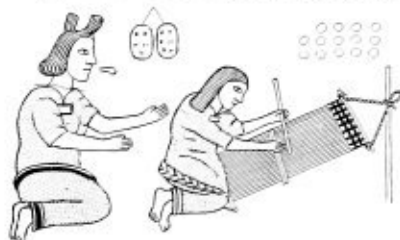

Simpler still seems to have been the loom of the Aztec and the Maya mother who taught her daughter to weave. As the illustration, copied from a picture story of the time, shows us, the girl was then fourteen years old, and as a reward for well doing at her task was allowed two full tortillas or cakes of corn.

The weaving of the Navajo and other Indians of the Southwest has no doubt been affected somewhat by the influence of their Spanish-Mexican neighbors, but it is still remarkable for its strange and striking, if not barbaric beauty. Such work has been highly prized by generations that are gone, but probably never brought so high prices as are paid now by those who appreciate art in forms unlike those which are conventionally regarded as correct, therefore beautiful.

All this spinning and weaving can be called purely native American. It was at least pre-historic American art. But the Pilgrims and others who settled on the Atlantic shore north of

the Gulf brought the first spinning wheels the New World ever saw, and with these came skill to spin fine linen and wool, and to weave honest cloth and beautiful napery. In those days every farmhouse, and many another home, held its spinning wheel, but not every pioneer mother owned her own loom. Many a good spinner was content to trust the weaving of her woolen yarn, her tow thread, and even her finest flaxen fibers to her neighbor who possessed a good loom with which to show her proud skill.

Such pride, and that spirit of eager industry which was born of limitless opportunity to do, urged men here to the invention and use of better devices for spinning, and better looms. Strange and beautiful fabrics were brought from the very ends of the earth, even from India and Cathay; at least from the land of the Turk or other pagan, and more often from the Netherlands and from France and England to gladden the heart and nourish the vanity of those having pelts, or tobacco, or grain to barter for such fineries; and to stir the envy of those many others who had none of those native goods to spare, therefore could not well have the velvets and the laces their hearts desired.

Naturally it came from such longings that the American textile industry has been created and its mills equipped with ingenious devices, often originating with American inventors whose ideas are copied in every civilized country of the world. Some of our looms are weaving silken ribbons so delicate that they could go through the eye of a needle, while others weave doormats inches thick; some weave tapes a mere fraction of a barleycorn in width, while others make rugs wide enough to cover floor of cottage parlor or mansion hall. Some weave veilings so light that a breath might blow them away, even while other looms are making canvas strong enough to hold the hurricane until it tears out the heart of the stout ship.



The early history of the textile industry thus interestingly told has been chosen as a fitting introduction to our own historical record. Mr. Perry has made his investigations and selected his illustrations for this special work.



The primitive methods of weaving are fairly illustrated by the vertical frame, in which the weft is introduced by a hand shuttle, as clearly shown.

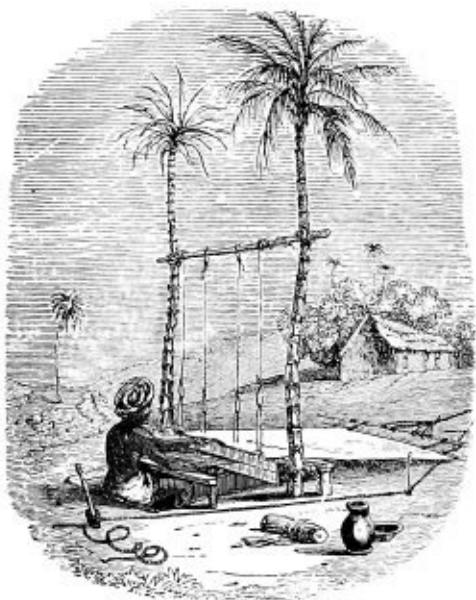

The Hindoo weaver uses a similarly primitive principle at the present day. Persian and Turkish rugs are woven with upright warps, the weft being inserted in small tufts by hand.



The next illustration, shows a Flemish weaver of the middle ages, also manipulating the shuttle by hand, and the harnesses by foot treadles. There is no record to show just when the warps were first led separately through heddle eyes and reciprocated with mechanical devices.

The next notable mechanical change was due to the invention of the fly shuttle by John Kay, in 1733. At this

time, in weaving broad cloth, it was necessary to have two weavers at least, one at each end of the lay to throw the shuttle to the other. By Kay's invention, one of the two men was dispensed with, and even on narrow weaving a weaver could produce at least twice as much cloth per day.

By 1750, the fly shuttle was in very general use in England. In 1760, the drop-box was invented by Robert Kay, son of John. In 1785, Dr. Cartwright took out his celebrated patent on the power loom, which had a slow introduction, for as late as 1813 there were but 2400 power looms in all Great Britain. The possibilities of power weaving, however, were well appreciated, and Francis C. Lowell, who saw the loom in England, returned to America and successfully produced a practical machine with the assistance of Patrick Jackson and Paul Moody. This was witnessed in operation during 1814, and the Waltham Co. was incorporated on the strength of its showing.

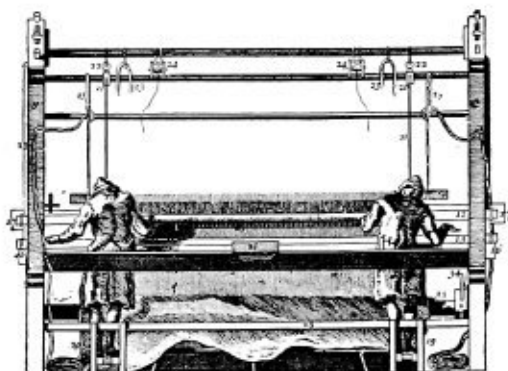

LOOM AS USED BEFORE KAY.

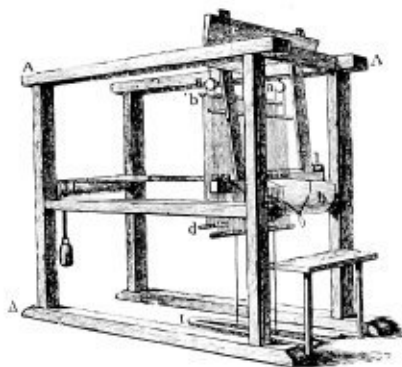

EARLY FLY SHUTTLE LOOM.

small pieces, and shipped here by way of France, as "small metal ware," requiring much of patience and perseverance to reconstruct the parts from the pieces.

William Gilmour brought patterns of the crank driven power loom to this country, and looms were constructed by him and operated at Lymanville in 1817. The manufacture of these looms was continued by David Wilkinson. The original patterns were surreptitiously sent out of England in

The price of cloth manufactured at Waltham in 1816 was 30 cents a yard, the price of the same cloth being reduced to 6 1-2 cents a yard about 1843. The early mills at Lowell were organized by those interested in the Waltham Corporation. The early interest excited by these Waltham looms, gave rise to the invention of the first practical self-acting temple by Ira Draper, in 1816. This invention, when perfected, doubled the capacity of the operative by allowing one weaver to tend two looms instead of one, on plain goods. Before the self-acting temple, the weaver had to intermittently move forward the clamps which kept the cloth stretched at the selvage. The temple business thus originated has remained with the descendants of Ira Draper to this day, our Draper Company furnishing practically all of the loom temples used in the United States at the present time.

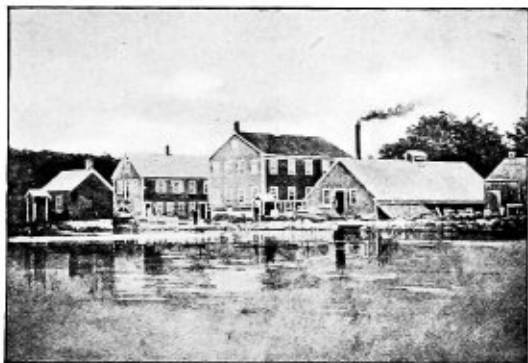

The central shop shows where temples were regularly manufactured in Hopedale after acquiring an interest in the reciprocating temple of Elihu and Warren W. Dutcher. The small building at the right was the early foundry for the Hopedale industries. The pond in front is now covered by Draper Company buildings.

SIDE ILLUSTRATION OF THE ROBERTS LOOM.
 A Typical English Product as Marketed About 1830.

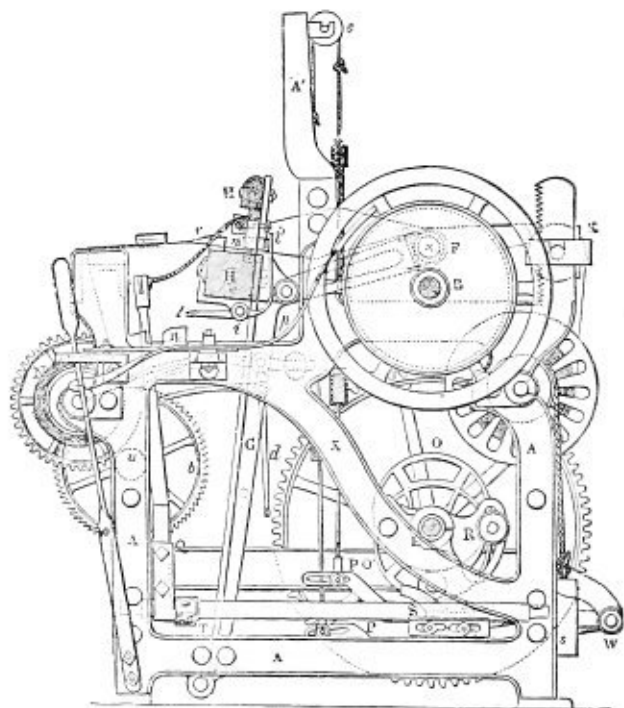

Although by 1830 power looms were widely used, they had no filling stop-motion, requiring active oversight of the weaver to note when the filling broke or ran out. They had no automatic let-off motions and the take-ups were not of a positive character, the whole machine being therefore ill adapted to produce even goods without continual adjustment by the operative or overseer.

Power looms were built at Taunton by William Mason, as early as 1829. None of the other earlier builders have continued in the trade. Many mills of the early period built their own machinery in small shops connected with the establishments. The early progress of the art of weaving is nowhere better illustrated than in the work of Clinton G. Gilroy, published in 1844. It is hardly safe to trust the early history there depicted, as Gilroy was something of a humorist; but it is evident from his clear description of machinery then in use, that at this time there existed power looms capable of producing all sorts of intricate patterns, together with carpet looms, embroidery machines, etc.

William Crompton, of Taunton, invented a pattern surface fancy loom in 1837. George Crompton made important inventions in this field and continued development in this line has been effected in the Crompton and Knowles works, of Worcester.



The Japanese weaver with hand shuttle shows a method still in use in spite of modern improvements.

After the adaptation of the weft fork, automatic let-off motions and parallel shuttle-motions, which were all applied before 1860, the plain loom remained practically stationary and unimproved up to the date of the Northrop inventions. Automatic change of filling was no new idea in the art, an attempt having been made by John Patterson Reid and Thomas Johnson, as early as 1834, with continuous other attempted solutions of the problem by various foreign and domestic inventors during the interim. The possibilities of automatic weaving, as now thoroughly established, are well illustrated by comparison with the product per operative at intermediate stages in the history of the entire art. It is possible that the crudest looms of pre-historic time required one minute to lay each pick, considering that no harnesses were used to separate the warp sheds. We have reason to suppose that the hand loom before Kay produced at the rate of about 20 picks per minute, doubling to 40 picks after the introduction of the fly shuttle. With improved construction and possibly greater skill, the product of hand looms has been increased until a speed of 60 picks per minute has been averaged

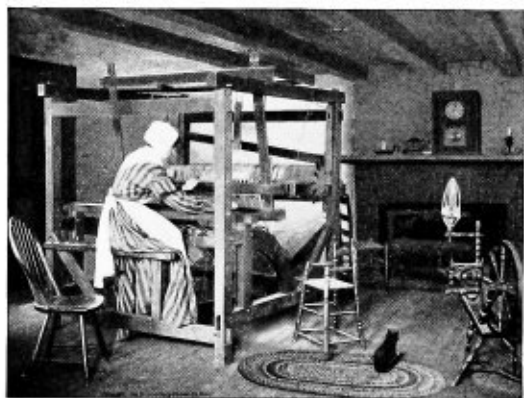

in recent times. The early power looms probably started about 100-picks per minute, gradually increasing till by 1850, in America, print looms were running at a speed of 150 picks per minute, with operatives tending four looms. Possibly they ran even faster in England, but the operatives there only tended two looms. Today, English operatives run four looms each, at speeds of 220 picks per minute, and American weavers from 6 to 10 on plain goods, at speeds for narrow looms of from 190 to 200 picks. With the Northrop looms, it is easily possible for a weaver to run 24 looms on similar goods, showing that the improvements represented in the Northrop loom give much more advantage, as measured by product per operative, than all the other loom inventions of history put together.

There are four primary inventions, which in turn have doubled, or more than doubled, the product per weaver—the fly shuttle, the self-acting temple, the weft fork and the filling-changer. There are several claimants for the weft fork, but two of the four are clearly American in origin.

“The Northrop-Draper loom has had many tests and made many records. We will now chronicle one that, in romance, surpasses the loom of this make at Tucapau mills, Wellford, S. C., which ran nearly 24 hours without stopping a second:

—Young couple engaged—against wishes father—hurried consultation—wedding party gathered in the dynamo-room—returned—the bride finding all her Northrop looms running along as merrily as ever.”
—[*Textile Excelsior*.

“A few nights ago the night watchman of the mill told of seeing strange sights and hearing queer noises during the small hours of the morning. He is a sober man of middle age and in perfect health, so it was hard to find reason for not believing his story.

He says that shortly after midnight he heard a noise in a remote corner of the mill like the running of weaving looms. He went there and found six looms running at full speed without any apparent motive power and cloth was being woven without any guidance.”—[*From dispatch to the New York World, Nov. 17, 1900.*

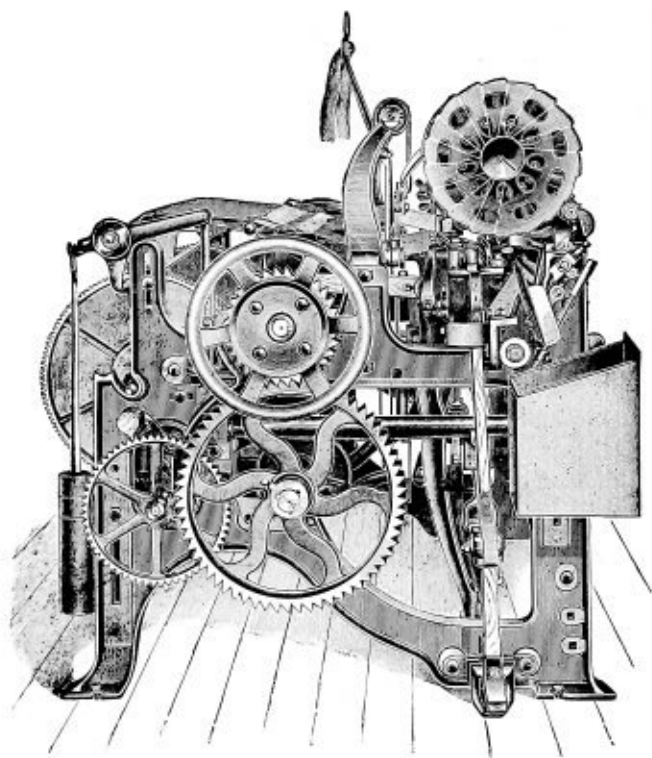

END VIEW OF A MODEL LOOM.

Not now built. This was the loom sent out on the Queen City, Tucapau, and other early orders. We built this model with right and left hoppers, not having then adopted our one-hand loom construction.

Steel Harness, Saw-tooth Gearing, Shepard Let-off, Mason Take-up, Movable Bobbin-chute and other details as originally presented.

HISTORY OF THE NORTHROP LOOM.

In order to avoid the usually inevitable misstatements made years afterward concerning the early conception and introduction of important inventions, we will briefly record the pertinent facts concerning the early history of the Northrop loom.

On July 26, 1888, Mr. William F. Draper, Jr., then member of our firm of George Draper & Sons, heard of a loom invention in Providence, and saw the inventors and their device, which was an automatic shuttle-changer. He reported at home that the general idea was interesting, but the device not practical, in his opinion. We then had an exhaustive investigation of the patent situation made through competent counsel. The report seemed to show that there was little novelty in this special application of the idea, but the firm had become sufficiently interested to risk a further trial of the general principle, and on December 10th voted a sum of \$10,000 for experiments, and started an inventor, Mr. Alonzo E. Rhoades, on the task of devising a practical shuttle-changing loom. That Mr. Rhoades lost no time is proved by the fact that he had an operative loom ready to be started, with warp and filling, by February 28th of 1889. This loom, after being reconstructed with new patterns during the next few months, though not changed in principle, ran with good success. Some twelve years later, for purposes of patent litigation, it was started up and run for days under the eye of a patent expert, accomplishing its purpose so well as to draw forth his unqualified approval.

Leaving the Rhoades loom at this stage, it is necessary to retrace our history to the year 1857, when Mr. James H. Northrop was born in Keighley, England, on May 8th of that year.

After becoming an expert mechanic and factory foreman in his own country, Mr. Northrop came to this side in May, 1881, soon drifting to Hopedale, where he became employed as an expert on metal patterns. His invention of the Northrop Spooler Guide brought him to the notice of his employers, and he was selected by them to work out the idea of an automatic knot-tyer for spoolers. Although showing great ingenuity, the devices as devised did not appear commercially practical, and the inventor became sufficiently discouraged to abandon the shop and devote his time to farming. Not finding this occupation congenial, he applied for employment some years later, in the fall of 1888, but the only opening then present was a job as mechanic at \$2 per day. In February, Northrop, who had noted the progress of the Rhoades idea, spoke to Mr. George Otis Draper, who had just entered the firm, stating that if given a chance he could put a shuttle changer on a loom in one week's time, that could be made in quantities for a cost of \$1 each. On March 5th, Mr. Draper drove to his farm and saw a rough wooden model of his idea, which was set up in his hen house. At Mr. Draper's recommendation, the firm ordered another loom for experiments, and after its arrival Mr. Northrop was started on April 8th to work out his scheme. By May 20th he had concluded that his first idea was not practical, and having meanwhile thought out a new plan, he asked for an extension of time until the fourth of July in which to perfect it. On July 5th, the completed loom was running at speed, and as it seemed to involve more advantages than the Rhoades pattern, the weaver was taken off of the Rhoades loom and transferred to the Northrop. On October 24th a loom with new construction, from revised patterns, was running at the Seaconnet Mill in Fall River, and more looms of the same kind were started up there at intervals. Mr. Northrop had, however, meanwhile thought out his idea of changing filling in the shuttle, some of the parts of such a mech-

anism taking shape as early as October. The development at our works continued so favorably that by April of 1890 several filling-changing looms were started in the same Seaconnet Mill, the shuttle-changing looms having been changed back to common looms, in view of the additional advantages of the filling-changing pattern.

Anticipating the great importance of the new inventions and the inevitable attempt at competition by shuttle-changing devices, we made an early and exhaustive investigation, both in this country and in Europe, to determine just what had been accomplished by all the inventors of record who had formerly tried to solve the problem of automatic weaving. It was found that many of the patents merely illustrated ideas worked out on paper, but never applied to looms, for they were absolutely inoperative as shown. Of the actual attempts, all had been complete failures. One of the inventors prominently connected with the art died in a poorhouse, and others lost material funds. In a recent law-suit, although it was asserted by our opponents that some of these looms were practical, **they did not present one particle of verbal, written, or printed evidence to show that any of these experimental looms had ever been witnessed in operation.**

Our early experiments showed us clearly that it would not be generally feasible to apply our attachments to looms as then constructed, since the ordinary plain looms were not uniform in size, shape, or fitting. We therefore began the design of a complete new loom and prepared for its manufacture. Several years of delay now intervened by reason of the necessity for perfecting the inventions and arranging for detail of manufacture, also since it was found advisable to incorporate a warp stop-motion with the filling-changer. Although patents had disclosed warp stop-motion mechanism for over 100 years, there were no known practical operating devices which could be adopted, so

our inventors had to start afresh and design the necessary mechanism. We were not inclined to put the labor and expense of testing the early mechanisms on the cotton mills themselves, so equipped a complete weave room of 80 looms and ran it continuously for many months. In June, 1894, we began the taking of orders, and early in '95 complete Northrop looms were started in our customers' mills. During the summer of '95, looms were exhibited in London by General Draper, and in October, '95, looms were also exhibited at the Atlanta Exposition. Orders for several thousand looms had been taken, based entirely on the showing of our own weave room, and during this year looms were started by the Queen City Cotton Mill, the Pacific, the Merrimac, the Grosvenor Dale, the Social Company, the Tucapau, the Lawrence Company, the Cocheco Company, Pelzer Mfg. Co., etc. It is interesting to note that **every one of these early mills has since given us large repeat orders.** The country was slowly recovering from the panic of '93, and mills were hardly in a condition to spend large outlay for new machinery, but the demands of the trade forced us into great enlargement of plant and facilities.

During 1896, an important test of our looms was made in Russia, where a complete set was run for many months with perfect satisfaction, so far as the mechanical performance of the looms themselves was concerned. A curious appreciation of the ingenuity of our mechanism was shown by the fact that the help could not understand how mere mechanism could produce such marvelous results, and they would not touch the machines until a priest had looked them over and sprinkled holy water upon them. During this year, an important and expensive investigation of our patents was made by large prospective customers, who later gave us large orders, being thoroughly satisfied that we were strongly protected by our patent claims. In 1897, important licenses were given several foreign manufac-

turers. During the year, the Amoskeag Company made a contract with us for warp stop-motions for some 12,000 looms. In 1898, a new plant was built at Valleyfield, Canada, to supply Northrop looms to Canadian customers.

The wide interest caused by the introduction of our epoch-making invention naturally started others to considering the possibility of competition. The Hunt loom had been brought on from California, the Emery vertical loom had been advertised to the trade, and the Crompton Loom Works had brought out a shuttle-changer. In 1899, shuttle-changing looms were sent out from Readville. The Bryan inventions were being exploited in the South, and the Perham loom was being shown at Lowell. The electrical filling-changing feeler of Malcolm G. Chase was also exciting more or less interest. The Hunt loom had an erratic and unimportant career. The Emery vertical loom hardly merited the enthusiasm of its promoters. The Crompton loom was withdrawn from the market. The Bryan loom never reached a market, the Perham loom quickly demised, although a large plant was bought and equipped to meet the expected demand. The Chase invention was acquired by ourselves, leaving the Harriman loom as the only survivor of this special aggregation at the present day.

In 1900, we were visited by a delegation of Japanese manufacturers, who left large orders with us. During this year, we started suit against the American Loom Company, then introducing the Harriman inventions. Our looms were shown at the Paris Exposition by several of our Foreign licensees. We had been making large additions to our plant to take care of the increased demand; in fact, we had entirely changed our manufacturing facilities. By 1901 we were employing more hands than had ever worked in an American Cotton Machinery shop and were occupying more floor space than any other similar concern. We were then shipping looms at the rate of 2000 per month.

During 1901, we acquired important ownership in a large range of patents then owned by Messrs. Baker and Kip and Coldwell and Gildard, giving us the exclusive rights for use of all the Baker and Kip patents, except those particularly relating to warp stop-motions, and giving us exclusive rights for use of the Coldwell and Gildard inventions on mechanical warp stop-motions. We were at this time bringing out our large hopper, which has since proved to be a notable improvement, allowing a much larger reserve supply of bobbins. During this year, suit was entered against us by Henry M. Hewes, on a shuttle patent of J. H. Nason, Hewes assuming that the shuttle used with our looms infringed the hand-threading Nason patent. In the final trial and decision, we were held not to infringe. At this period, the Lewiston Loom Works were advertising to equip their looms with the Harriman attachments. Many English shuttle-changing inventions were being exploited in that territory. The Thissell shuttle-changing loom was being exhibited at Lowell.

During 1902, the British Northrop Loom Co. was organized. During this year, we took our largest order, namely; that of the Grosvenor Dale Company, which thus definitely decided to equip all its plants with Northrop looms. In view of the fine character of the goods, and the reputation of the Company, this sale had great significance. On July 1st, 1902, our unfilled orders for complete Northrop looms, figured 21,586. Delegations of foreign business men, operatives, and labor unions, were visiting this country, to investigate the claimed advantages of the Northrop loom. We were forced to again make large additions, increasing our foundry alone to cover six acres of ground.

During 1903, there was considerable comment on the trials of long bobbins and warp stop-motions on common looms, in the attempt to make the common loom compete more success-

fully with the automatic. The help made stubborn protest against the change, and in looking back from the present period, it is seen that the results finally accomplished hardly warrant the early excitement. The warp stop-motions could not lessen the warp breakage and the long bobbins caused more stops through broken filling. Certain mills did discover that good weavers had not reached their limit with eight looms but in trying to force the average weaver to greater exertion they aroused an antagonism that was in part responsible for the most noted strike in cotton mill annals.

In the next few years, the introduction of our looms steadily continued. We took up the manufacture of bobbins, enlarging our works again to include a complete bobbin-making establishment. Fresh supplies of capital and persistent introduction, brought about the sale of certain lots of shuttle-changing looms during 1906; the introducers having again taken up the old shuttle-changing principle after a brief trial with removable filling-cases. We were by this time giving more attention to broadening the field of the Northrop devices, successfully using the Northrop looms on certain grades of woollen and worsted goods. We had already met with great success in the broad loom field, were selling many dobby looms and proving that our loom could be successfully used with jacquard motions. We were also entering the fine goods field with marked success, and also proving that our loom was perfectly adapted for cop filling. Our foreign licensees continued to increase the use of the Northrop loom abroad, the British Company especially making interesting progress. At the time of writing, the Northrop loom principles are more firmly established than ever, and more generally recognized. There is no question today in the minds of unprejudiced men, but that automatic looms are going to continuously and persistently displace the common loom.

THE NORTHROP INNOVATIONS.

The Northrop loom, as known to the trade, is distinctive in being the **first** commercial loom to ever supply filling automatically; the **first** loom to automatically supply a bobbin or cop-skewer to a shuttle and automatically thread the same, either commercially or experimentally; the **first** loom to ever incorporate a practical warp stop-motion for general weaving application and the **first** loom to automatically supply itself with filling before exhaustion of the running supply. As a whole, it is also distinct in the trade as being the **first** to do away with the old right and left hand system, the **first** to generally adopt the high-roll take-up, and the **first** of American manufacture to have a machined frame. For the benefit of those who have not seen the mechanism, we reproduce an illustration showing a section of our earliest commercial type, in which the transfer of a bobbin to the shuttle from a circular hopper, is fairly well illustrated. The empty bobbin is seen descending on a chute into a bobbin receptacle. The details of the mechanism now used are entirely different, but the fundamental principle of detecting the absence of filling by a filling fork, and thus causing a forward motion of the lay to rock a transferrer, or pusher, forcing the lowermost bobbin from the hopper into the shuttle, where it is retained by springs which grip the rings on the base of the bobbin, simultaneously displacing the empty bobbin, is clearly illustrated. The thread from the end of the bobbin is seen leading to the hopper itself. As the shuttle is picked, this thread is automatically led into its self-threading eye. Although the cut shows the hopper on the left side of the loom, our present looms are all made with the hopper on the right hand side, except when we change over old looms of other make, in which case both-hand hoppers are necessary.

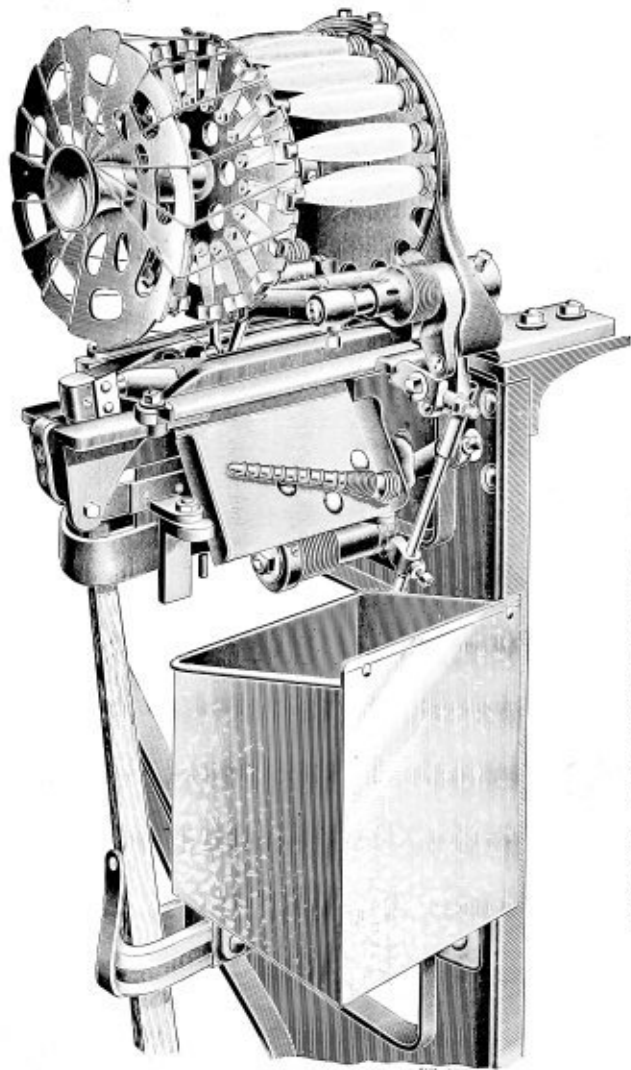

DETAIL OF HOPPER MECHANISM ON A MODEL LOOM.

(Other parts of loom erased.) Shows empty bobbin falling into box while fresh bobbin is being inserted.

Our warp stop-motions are all mechanical, depending upon the support of a thin steel drop-wire, or heddle, by an unbroken thread. If the thread breaks, the drop-wire, or heddle, drops a predetermined distance into the path of a moving detecting apparatus, the stoppage of which causes the stopping of the loom. Our looms for perfect cloth utilize a "feeler" mechanism, which introduces a detector within the shuttle, to determine when the filling is nearly exhausted, to then cause operation of the transfer to supply new filling before an empty, or partly empty shed can be left in the cloth.

The filling-changer, of itself, simply allows the weaver to let the loom run without replenishment of filling for much longer intervals; also lessening the number of hand operations necessary. By reducing the necessity of both oversight and labor, the weaver can take care of more looms. The warp stop-motion is necessary in order to protect the product from warp runs while the weaver is thus limited in chance for oversight, the combination of the two devices greatly increasing the possible product per operative.

To appreciate the great saving introduced by the filling-changer, it may be well to note the operations gone through by a weaver on a plain loom, when the filling is exhausted. They follow in the sequence now recorded, the weaver performing the following functions:

1. Releases the shipper brake.
2. Pushes the lay back.
3. Withdraws the shuttle.
4. Puts the reserve shuttle in the shuttle box on the lay.
5. Pulls the shipper handle to start the loom.
6. Rubs the cloth below the breast beam to prevent a thin place, if light goods are being woven.
7. Picks up the discarded shuttle again.
8. Pulls the shuttle spindle out on an angle.

9. Removes the empty bobbin or cop tube.
10. Puts in a new bobbin or cop.
11. Pulls off a sufficient length of filling.
12. Snaps the shuttle spindle back into place.
13. Holds the filling over the shuttle eye entrance.
14. Sucks the filling through the eye.
15. Places the shuttle in its holder, where it remains until needed.

Now, this series of performances must be gone through with **every time the filling is exhausted.** On one loom, the filling may run from one minute to twenty minutes, according to the size of the yarn and the amount of yarn in the shuttle. The average time is perhaps six minutes, especially if we count the number of times that the weaver must come to the loom to start it up when the filling breaks. With a loom having an average of six minutes between such stops, the weaver must come to the loom once every six minutes. If running eight looms, he would have such a duty oftener than once a minute. With the Northrop loom, on the contrary, the weaver can fill a hopper containing 25 bobbins, which, with the same average of running time, would last two hours and a half, without requiring attendance. A co-operating feature of great advantage with the Northrop loom is the fact that the weaver can fill the hoppers at convenient intervals, rather than be forced to come to the looms with irritating regularity.

Referring to the associate attachment, the Warp Stop-Motion, it is, of course, well known that the warp threads will break in weaving. On a common loom, the broken thread will not be raised by its heddle, and thereby leaves an open space in the cloth, more or less visible to the eye, according to the character of the goods woven. Very often the broken end gets tangled around adjacent threads between the harness and the reed, holding several of them either above or below the tip of the shuttle,

which therefore causes a defect known technically as a "float" or "overshot." If the weaver does not notice the fault promptly, the extra strain will break many of the warp threads, and in any event, a pickout is necessary. In some mills, a weaver is forced to stop all looms under his charge while attending to a pickout. It is not necessary to explain the trouble caused by these defects to any weaving expert. The temples must be pulled back, all the filling threads that have been laid since the tangle commenced removed by a tedious combing operation, the warp beam must be turned back, the tension of the cloth properly adjusted, and the loom again set in motion.

We started with the assumption that the Northrop loom would enable a weaver to produce a double product. We have actual records of mills today where weavers produce six times their former common loom output, on certain distinct classes of weaving. A triple product is by no means uncommon; and we state with positive conviction, that if there be any mill which does not today get a doubled former product from the Northrop loom, **it is because of conditions for which the loom itself is in no way responsible.** There are difficulties involved in the application of the Northrop principles to old looms which make it necessary that most of the old looms shall be replaced. We buy thousands of good common looms, which are exchanged for Northrop looms, and melt them over into Northrop loom parts. It is no slight task to practically replace the entire equipment of the most important manufacturing department of one of the greatest world industries. It cannot be done in one decade, it cannot be done in one century. The power loom itself was introduced over one hundred years ago and yet there are large countries which still make most of their cloth on hand looms; in fact, it is possible that more than one-half the people of this earth depend on hand weaving for the majority of the cloth that they use.

The natural growth of the cotton weaving industry of the United States, requires over 20,000 new looms, per year, without counting the new looms also necessary to replace worn-out machinery. Our product has averaged over 15,000 looms a year for several years, and a considerable fraction of this output replaces old machinery. To replace the entire amount of common looms that are weaving goods suitable for automatic applications, and also supply the yearly demand for similar looms, would require an output far beyond our present facilities.

There are good reasons why the introduction should be gradual. The profits made by use of improvements are only possible while there is a comparison in price of production between the users of the improvements and those who do not use them. We wish to give our early customers a sufficient profit from their machinery, and we also wish to give present purchasers proper profit. They will be assured of profit just so long as any considerable element continues to use more expensive methods of manufacture.

"The wide interest in automatic weaving which is now developing in England brings forth very interesting newspaper discussions. Our policy of breaking up second-hand looms replaced by the Northrop, for instance, calls forth the following comment:

"So what is done by one big firm who make automatic looms, when it gets an order? It takes the ordinary looms, which may be quite as good, as part payment for the new. It doesn't use them. It just smashes them into uselessness. That is, on the face of it, the throwing away of thousands of pounds. It is a thing, I fancy, no Englishman would have the courage to do. But look at the longsightedness; it is putting out of the market a huge quantity of looms, and so, partially by inducement, partially by compulsion, forcing on the time when all manufacturers will take to automatic machinery, and then will be the time when the huge harvest will be reaped."—[*Cotton Chats, Jan., '03.*

"One man who came under my personal observation was working 27 looms. He was producing a print cloth, 28 inches wide, 60x64 ends per inch, 29's warp and 37's weft. The average for the whole mill was about 19 looms per weaver. Is it possible for our manufacturers to compete with this?"—[*English expert's report on visit to America, from English paper, October, 1902.*]

"The cloth is as near perfect as can be. Weavers run, or attend, from 16 to 28 Northrop looms, and do not work any harder than I have seen them do on eight common looms, and pretty near all the weavers here are what would be called new weavers; that is, having only from two to three years' experience; and, in fact, the majority of them learned here."—[*Contributor to Wade's Fibre and Fabric.*]

"The Northrop looms at this mill are running on 60s warp and 70s to 80s filling. I have never seen looms run any better, on coarse numbers even, than these are running; in fact I do not see how any looms could do better. The weavers run 16 looms each and did not seem to have anything to do. The overseer called my attention to his loom fixers on these looms sitting down by their bench sleeping, which he said was no unusual sight. He says he gets all of 95 per cent. product."—[*Extract from Expert's Report, June 20, 1903.*]

"Mr.———said the only fault he can find with the Northrop looms today is that they use too much filling. Since he came here he has had to put two extra spinning frames on to spinning filling for these looms, and now he has just put on the third."

(In another mill). "Mr.———, the overseer of weaving, says they are getting 93 per cent. product from the Northrop looms, 26 looms to a weaver, 163 picks per minute."—[*Extract from Expert's Report, Dec. 12, 1903.*]

"The work at this mill is running very nicely indeed. They now have some weavers running 30 looms each, and with all their looms running—1292 I understand—they have only 59 weavers at the present time, and expect to spread the weavers further the coming week."—[*From Expert's Report of Jan. 16, 1904.*]

"The weavers are still running 20 looms each here, but it is hardly enough for them. There was less than 5 per cent. of the looms stopped, and the overseer thought I had made a mistake in count, as he said he was weaving 98 per cent. right along."—[*From Expert's Report of March 26, 1904.*]

"On their print looms, the weavers are running from 16 to 28 looms. Most of the weavers, however, are running 20, 24, and 26. They pay for weaving 5½ cents per cut of 52 yards."—[*From Expert's Report, of April 16, 1904.*]

"In No. 1 mill I saw one room with 216 looms in it being run by six weavers. These weavers run 36 looms each, cotton harness and double-thread stop-motion. The goods are 80x88 25s warp 33s filling. Four boys fill the batteries for this room, and they are getting as much product as when the weavers ran 24 looms each and filled their own batteries. The overseer says he expects to get a larger product than before. The weavers like this arrangement better than the former one. The overseer told me that the weavers tell him that filling the batteries is more than half of their work."—[*Expert's Report, April, 1904.*]

"They have an average of about 18 looms to the weaver, and are making prints 64x60, paying 6 1-4 cents a cut for 54 yards."—[*From Expert's Report of May 7, 1904.*]

"Called at the———Mills; found them exceedingly pleased with the Northrop looms. They are getting an average of between 26 and 27 yards per day, which is more than two yards more than they get from their common looms. They are weaving 78x80 goods, 40" wide, 52 yards, and pay 20 cents a cut against 42 cents. The weavers are running 20 looms; there are two fixers on 204 looms, and the only extra help in the room is two boys for cleaning and oiling."—[*Salesman's Report, Oct. 10, 1903.*]

"Their weaving is running extremely well, and they have on 1182 looms, which they have been running an average of about 19 1-2 looms per weaver, and Mr. _____ is sure they will be able to bring it down to an average of 22 looms to the weaver throughout."—[*Expert's Report of Nov. 14, 1903.*

"Their Northrop looms were all running very well; the weavers run 18 prints each, and on the wider looms 16 each; the fixers run 115 looms each."—[*Extract from Expert's Report, Jan. 2, 1904.*

"I have never seen the loom run as steadily as they are today. Mr. _____, overseer of weaving, tells me that he is getting 92 per cent. product right along, and has a large number of looms on 100s warp and 120s filling. The weavers run 16 looms each, and about every weaver has two looms out of the 16 running with two shuttles, cotton warp and silk filling, very light goods which they are making on the Northrop loom because they get better goods than they can on the _____ (Another make of loom.)—[*Salesman's Report in June, 1905.*

"I found one mill in the South which had 5 weavers, with 40 Northrop print looms each, getting an average of over 90 per cent. without help from filling boys; in fact, the scarcity of small help in the South has practically eliminated the use of children to assist in filling hoppers. At another mill there were 16 weavers running 30 Northrop looms each, on sheetings, without assistance, getting an average of 93 per cent.; in fact, the 30-loom weavers averaged a higher percentage of product than those with 24 or 20 looms. At another mill they averaged 22 print looms to the weaver through the whole mill, which has a very large equipment, and they get 100 per cent. production, since the looms run over time sufficient to cancel the actual loss made during the regular 11 hours. These are wonderful showings for a machine with only 11 years of introduction, which started with a basis of 16 looms to the weaver."—[*Cotton Chats, Dec., '06.*

PRICES AND PROFITS.

The price demanded for a new machine should bear a pertinent relation to the profits to be derived from its use. The machine itself may be absolutely efficient, accomplishing all that its promoters claim, and yet demand a price prohibitive by reason of the capital required. On the other hand, a new machine may be sold so cheaply as to give little encouragement to the builders to continue its improvement, through the only possible channels; namely, expensive experiment. Contrary to a popular fallacy, inventors rarely devote their time and energy entirely for the good of the world at large. Those who develop and introduce the inventions are certainly not so impractically altruistic. There is no reason why the customer should not pay a proper price for value received; and yet, in the general introduction of inventions, it is necessary to give the customer the lion's share of profit, in order to secure his approbation. The value of our spindle improvements to the world at large has recently been estimated at two hundred and fifty million dollars; and yet the return in price paid for the actual spindles themselves, sold within the period referred to, would be under twenty-five million dollars, which payment must cover the cost of the spindles themselves, the cost of the patents, the cost of expensive litigation, and all the experiments, advertising, and general expense connected with the industry.

The introduction of our spindles was comparatively easy compared with the introduction of our loom, for the early price of new spinning with high speed spindles was actually less for a given product than the slow running frames, while with our loom the price is nearly three times the price of the competing loom,

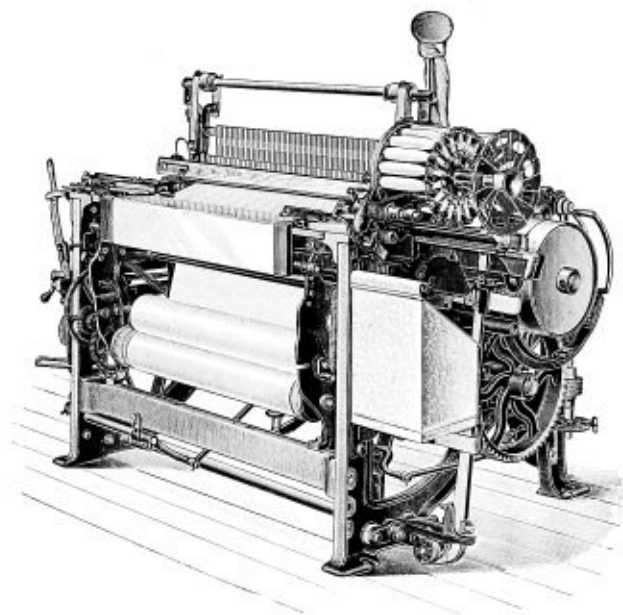

B MODEL.

Not now built. This pattern was continually improved and was our standard for prints and other light goods until 1898. It had a wider frame than the A model, longer shuttle boxes, new take-up, Stearns rocker and One Hand construction.

"There can be no doubt that the enormous expansion of the American cotton industry during recent years has been very largely owing to the Northrop loom, and the conviction is steadily gaining ground in this country that only by the general adoption of the Northrop loom can our cotton trade be put once more upon a thoroughly sound basis."—
[Letter from London correspondent to The Indian Textile Journal, printed September, 1903.]

so far as the amount of product is concerned. There is always a protest against higher prices, no matter what the advantages may be.

Looking at the introducer's side, it is evident that, having but seventeen years of patent protection, several years of which are usually used up before actual sales are made, he must make enough out of this limited period to repay all of his expenditure involved in perfecting, protecting and introducing his idea, as well as a fair bonus to repay for the risk of attempting to improve in the first place. The profits must also cover the expense of hundreds of useless experiments, thousands of disused patterns, possible litigation, extensive advertising, replacement by improved parts, etc.

The average piece-price for goods woven on Northrop looms is probably a little less than half the former weaving rate. To offset this gain we have an increased cost of the loom itself, with loss of interest on the extra investment money, and a very slight increase in repairs and fixing, although there are mills which claim that their expenses in this line are actually less with the Northrop loom. Roughly figured, the gross profit on the loom should run from \$20 per year per loom upward. It varies with the scale of wages paid, and the number of common looms formerly tended. The weaver that changes from four common looms to twelve Northrop will show a greater gain than one who changes from eight to twenty. There are many incidental advantages in the lessening of the number of operatives required. **When we take half the help out of the main department of a mill we greatly lessen the number of tenements necessary, lessen the cost of bookkeeping and paying off and less personal attention is required from the supervisors.**

Our loom, being automatic in character, requires much less

skill and training in the operative, for it is easy to learn to run Northrop looms; in fact, green help become accomplished weavers in a much shorter period than with common looms. As the loom is automatic and therefore more responsible for errors, there is less chance for trouble with the weavers over bad work and fines. Some of these matters may seem small in themselves, but they amount to considerable in the aggregate.

No labor-saving device attains its full efficiency in the first few years of use. Our later large hopper looms have certainly enlarged the scope of the weaver, and continual improvement will gradually reduce warp breakage and loom stops due to various other causes.

The problem of how to increase earnings is often solved by enlarging the plant, but less money applied to the improvement of a present plant may sometimes give far greater returns with much less inconvenience. The change from common to Northrop looms requires no addition to floor space. As above noted, it greatly decreases the number of operatives, and therefore solves a most perplexing problem in localities where weavers are scarce. If the old mills will not appreciate these facts they must face the competition of the new mills, which start with more modern equipment. We are frank to say that the hesitation of many of the older mills has been distinctly disappointing, for we should like to see them share in the benefits of our new ideas on account of the friendship founded on long and intimate associations. Failing to induce them to take the majority of our products, however, we must in justice to ourselves encourage the building of new plants. We should, if necessary, place our looms, even if we had to build and operate mills ourselves in which they were used; for we are absolutely convinced that the mills with our machinery can make profits in straight competitive lines at prices which will drive the older, poorly equipped mills, out of business. If there is demand enough to

make a profit for all, **the mills with our machinery will make the greater part of it**; and when there is no profit at all for the older mill, the newer mills can at least keep a balance on the right side of the ledger.

It is not to be supposed that the introduction of a revolutionary machine like the Northrop loom is effected without difficulty, annoyance and delay. Those who use common looms and have not immediate chance for replacing them are naturally anxious that their competitors should not adopt advantageous improvements. Those who sell common looms are averse to acknowledge the merits of their competitors and the influence of a large body of manufacturers with their salesmen and personal friends is of acknowledged weight and importance. There is also a limited class who have made unsuccessful experiments with certain lines of weaving with the new devices and who are not disposed to admit that the other mills can be more successful than themselves. All of these opposing elements together create a certain atmosphere of doubt and a disinclination to accept facts.

Some time ago we were permitted to see a record from the books of a large Northern mill using both Northrop and common looms. The figures were based on a low scale of weaving wages for the common loom. The figures showed an actual difference of \$23.52 per loom per year in favor of the Northrop loom above all extra expense for supplies, fixing, cleaning, etc. The weavers on the Northrop loom also earned \$55.12 each, per year, above the earnings of the common loom weavers. This record is based on sixteen Northrop looms to the weaver. Some mills already run twenty-eight Northrop looms to the weaver.

On noting a broker's list of Southern cotton mill stocks for sale, with prices bid and asked, the writer, as a matter of curiosity, separated out the mills which had bought Northrop looms, and figured a comparison in the value of the stock as quoted. The price **asked** was taken in each case, the price bid

being added in only where there was no asking price. The total result showed that 28 mills **without** Northrop looms averaged a stock value, as thus figured, of \$102 a share. The 37 other mills, having Northrop looms, averaged on the same basis, \$114 per share.

Prices of looms vary somewhat with cost of materials and equipment desired. They should properly vary in proportion to the expense and utility of new attachments. We do not, however, add to the price of our loom when improving its fundamental features. It has been estimated that **we have actually added \$15 of cost per loom to our complete machine since its earlier stages.** We are glad to estimate on whatever looms are desired. Old common looms are taken in exchange at fair allowance under certain conditions.

When mill-men begin to figure on automatic loom profits they have sometimes adopted serious fallacies. There is grave chance for error in dealing with the items of interest and depreciation. For instance, if we assume a Northrop loom cost of \$140 and a common loom cost of \$50 to make the same goods, there is an extra cost of \$90 to be paid out of extra earnings. If we took 5% for interest = \$4.50 and 10% for depreciation = \$9, we have \$13.50 to offset against the loom earnings; but this is not fair figuring for each year as can easily be explained. The extra \$90 should be treated as if it were a debt to be paid. Now if at the end of the first year we charge 5% interest on the \$90, we have \$4.50 out of earnings but the 10% depreciation of \$9 is a practical payment of the debt to that amount and thus reduces the debt to \$81. It is on **this** sum that the interest for the next year is to be paid = \$4.05 and the depreciation is now but \$8.10. The columns following give the totals year by year.

Interest on	\$90 =	\$4.50	Depreciation =	\$9	first year.
"	"	81	4.05	"	8.10 2nd "
"	"	72.90	3.65	"	7.29 3d "
"	"	65.61	3.28	"	6.56 4th "
"	"	59.05	2.95	"	5.90 5th "
"	"	53.15	2.66	"	5.32 6th "
"	"	47.84	2.39	"	4.78 7th "
"	"	43.06	2.15	"	4.30 8th "
"	"	38.76	1.94	"	3.88 9th "
"	"	34.89	1.74	"	3.49 10th "
"	"	31.41	1.57	"	3.14 11th "
"	"	28.27	1.41	"	2.83 12th "
"	"	25.45	1.27	"	2.55 13th "
"	"	22.91	1.15	"	2.29 14th "
"	"	20.62	1.03	"	2.06 15th "
"	"	18.56	.93	"	1.86 16th "
"	"	16.71	.84	"	1.67 17th "
"	"	15.04	.75	"	1.50 18th "
"	"	13.54	.68	"	1.35 19th "
"	"	12.19	.61	"	1.22 20th "
		20)39.55		20)79.09	
		Average = 1.98		Average = 3.95	

The average yearly interest and depreciation for twenty years is therefore \$1.98+\$3.95 or \$5.93. There is still some \$12.19 left to be paid on the original extra cost, but the extra mechanism will certainly be worth that much at that time—and considerably more.

Now, if a weaver earns \$10 a week on 8 common looms and is given \$12 a week on 24 Northrop looms with the same product per loom in each case, a perfectly feasible assumption, there will be a weekly saving on each Northrop loom of 75 cents, or \$39 per loom per year, a net saving with average interest and depreciation out, of \$33.07. If, instead of 24 Northrop looms at \$12 wages, we assume 20 Northrop looms at \$10 wages, the

saving is precisely the same, and it is certainly easier to run 20 Northrop looms than 8 common looms on the same goods. We claim that it is easier to run 24 Northrop looms, but we have conceded an extra pay on this number, to overcome the conservatism of the operative.

Now understand that the \$33.07 is **net** profit. Reduce it by every possible or unauthorized estimate and it must still be noticeable and important. Call it \$30 or \$25 or \$20 it is still \$300, \$250 or \$200 in 10 years (more, with allowance for interest on the savings) or \$600, \$500 or \$400 in 20 years.

Capitalize the saving of \$33.07 at 5% and it would show the Northrop attachments worth \$661.40 each. At 10% they are worth \$330.70 each.

In allowing a deduction of 10 per cent. depreciation we assume a cut far beyond that used by the average mill on any other class of machinery. Were] such a reduction made yearly on all machinery it would wipe out much of supposed profit and surplus.

There are many possible purchasers who have continuously postponed patronage in the hope that our prices might be reduced through competition, or because they thought we would continue to improve the mechanism and they wished to be sure of getting the very best mechanical construction. Prices might have changed—they may change—but in view of the expenses of making and introducing these looms, there will be no material change in price that should affect a customer in purchase. Some have waited twelve years or more, and lost a possible profit that would have paid for several purchases of looms.

"There are several concerns now organized which make a practice of appraising the value of equipment in establishments of various kinds. One of such recently wrote us about the value of some of our looms in a mill which they had been asked to investigate. They had been told the actual price paid, but insisted that there was some mistake, for they thought that such a complicated and well made machine should certainly be worth several times the value given. We can easily understand how appearances deceived them: for it is only by employment of the most improved processes and strictest use of economy, that we are enabled to keep our prices where they are. The foreign builders who make our looms from similar patterns, invariably charge a much higher price than we do, in spite of their cheaper labor."—[*Cotton Chats*, Oct., '04.

"Manufacturers would prefer to do away with the employment of small children, but in certain sections where parents must work, they often insist on having their children in the mill with them. There is a serious lack of sufficient good help at present, and if child labor is to be dispensed with, many mills must shut down. These conditions present an extremely difficult question; one that should be considered temperately, and with full knowledge of the subject. We believe the proper solution lies in the extended use of labor-saving machinery, and are constantly bending our efforts toward the production of a greater product per operative. The substitution of such machinery increases the labor supply, and usually increases the wages of the operative. Both limit the necessity for child labor, reducing productive costs in the most acceptable manner."—[*Cotton Chats*, March, '06.

"Mr. _____ said the last time the treasurer was there he wanted to go in and see the Northrop looms. Every loom was running and the weavers sitting down. The treasurer said that was enough, he did not care to see the rest of the weaving. The overseer told the agent in my presence that it is hard work to get weavers for his common looms, as they all want the Northrop."—[*From Expert's Report of March 26, 1904*.

"The mills now working under the disadvantage of being short in help can readily see how the Northrop loom immediately increases the number of operatives available. By putting in Northrop looms in a room where a considerable percentage of looms are now stopped, there will be plenty of weavers to run all the new looms, with a surplus of help which can help out other departments. A study of our present order list would show that many mills are following just such a system as we now propose."—[*Cotton Chats*, Oct., '06.

Some who will not acquaint themselves with the actual facts of the situation seem to think that our loom is still limited to print cloth and sheetings. As a matter of fact we weave about every class of product suitable for one shuttle looms. We have looms running with Jacquards, dobbies, cam motions, bag motions, centre-forks, centre selvage, etc. We not only weave prints, sheetings, shirtings, drills, twills and lawns, but also fine sateens, chambrays, window curtains, awning cloth, denims, duck, bags, towels, mosquito netting, table cloths and other countless varieties.

Not only do our looms weave these goods but they weave them well—give good quality with small per cent. of seconds. We know of mills that use Northrop looms for their most particular goods—in fact, some selling houses insist on having certain weaves made on Northrop looms.

“We have been running twenty-six of your Northrop looms for a little over a year and it has occurred to me that you might be interested in results obtained. Our percentage of seconds for the last three months from these looms, for all causes, such as thin places, button hole selvages, oil cords in filling, etc., is only 2.07 per cent. Goods weigh 2.85 yards to the pound, 18s warp, 15s filling. I believe this is a low figure, especially as these goods are all bleached and the bleachery reports that our grading of first quality is strict so that they have practically nothing to say to us except to hold the goods up to our standard. Conservative figures show that the looms are producing about 93 1-2 per cent. of theoretical production figured on our actual running time. We do not run them over time at all, as some mills do. Some mills may show a larger percentage than we get, but as the goods must bear rigid inspection I think the results produced are fair. . . . The looms give us little if any trouble in fixing, and repair account for them is very light. We are running them 170 picks, which is somewhat higher than you recommend for 45" reed space looms, but they give us no trouble in that respect.”—[*Letter received from customer Sept. 28, 1900.*]

“They say they have never had any complaint from the selling house in regard to the quality of their cloth, and some of the goods they are weaving in 6-cuts rolls, and sending it out even without inspecting it at the mill.”—[*Expert's Report of Dec. 12, 1903.*]

"We looked at the Draper looms, which are running extremely well, with weavers running 16 looms each on 4-shade cotton flannel, 17s warp and 9s filling. They are doing very well with the feelers and were making little waste."—[*Salesman's Report of Nov. 28, 1903.*

"I called at the——Mills: found the looms running very well. They have reduced the seconds on their plain work to 1 1-2 per cent. and on their sateens to one-half of one per cent. This is perfectly satisfactory to them."—[*Salesman's Report, Oct. 24, 1903.*

"It is always difficult to eradicate early impressions. When we started the introduction of the Northrop loom over ten years ago, we confined ourselves to prints and sheetings, using bobbin filling and 2-harness equipment. Many still think we are limited to medium or coarse filling, plain goods, and the use of bobbins rather than cops. I was in a weave room recently, however, in which over 800 Northrop looms were using cop filling, and none of the looms running with coarser than 50s warp or 60s filling. Most of the yarn was of much finer grades, running as high as 140s filling and 100s warp. One Northrop loom was equipped with a jacquard and several with dobbies. Some of the looms ran very difficult weaves, having but 72 picks of 120s filling per inch. The percentage of seconds was very low. The weavers were running from 12 to 16 looms each."—[*Cotton Chats, May, '06.*

"In a circular letter accompanying a five-per cent. semi-annual wage dividend, the treasurer of the Bourne Mills uses the following language in part:

'People pay for what pleases. Only a few weeks ago, one of the largest and shrewdest buyers in America said to me frankly, 'I would rather have your goods than any others.' It is no more than fair for you to know this because I wish you to feel that every one of you has a share in pleasing that customer. The goods speak for themselves, good or bad, and bear witness in some form of the touch of every hand that takes any part in producing them.'—[*Cotton Chats, Aug., '06.*

ATTEMPTS AT COMPETITION.

Whenever a successful and profitable device is made in any mechanical art, competition of some nature is inevitable. Those who wish to share in the profits of others' success first try to find how near they can copy without infringement of patent claims. If the departure be so radical and the patents so strong that no close imitation is possible, the only recourse of the aspirants is to take some formerly unsuccessful attempt and try to make it marketable. When introducing devices that are plainly not so good as the accepted machine, it is natural in these days of lessening regard for veracity to boldly claim that they are better. Sufficient persistence can sell certain quantities of product of any nature, especially since curiosity always promotes a trial of any idea that is well advertised. In our past experience those who asserted the superiority of differing devices, **promptly dropped their supposedly preferable product to copy ours just as soon as patent protection expired.** We believe our present competitors will similarly take backwater if they remain in business long enough to profit by patent expiration. Our competition up to the time of writing has included that of common looms, still urged on customers by their manufacturers; common looms adapted for longer filling bobbins; common looms with warp stop-motions; common looms with both long bobbin and stop-motions; and shuttle-changing looms. As to common loom competition, we think our chapter on comparison of costs sufficiently illuminating. The introduction of a long bobbin has no relevance, since **the Northrop loom will take an equally long bobbin,** and thus preserve the same comparative basis of saving. The application of a warp stop-motion to a common loom in no way diminishes the labor of the operative; in fact, it makes more labor for the

operative. There may be a percentage of saving, but such percentage in comparison with the cost of application could, even if proven, but simply emphasize the savings possible by use of **real** labor-saving attachments like the Northrop filling-changer. As to shuttle-changing looms, while exploited in many countries by dozens of interested parties, they do not meet with general popular approval, because of their excessive complication, and their inherent defects.

It is a common trick in diplomacy to anticipate criticism of defect **by over praise of the very thing open to criticism.** The very recognition of extra complication has led promoters to emphatically declare their mechanism simple by comparison. Shuttle-changers are necessarily complicated, they are necessarily limited in the amount of filling reserve, they introduce difficulties in the setting of the looms to accommodate many shuttles, and they still require the weaver to go through the operations of shuttling the bobbin and threading the eye. We do not claim that shuttle-changing looms cannot run, nor that they cannot show some saving in labor; but we do claim that they require **more** labor to run them, **more** labor to keep them in order, and **more** cost for repair than filling-changing looms.

Although we were the first to introduce warp stop-motions for general practice, we do not assume to control the entire field, although we do receive royalty from certain devices introduced by others. We believe we make the best mechanically operated warp stop-motions, and we can apply electrical stop-motions when desired.

As to the coming competition through copies of our own inventions, it is well to remember that the first commercially successful Northrop looms were not started in the mills of our customers till 1895. While certain patents issued earlier than this date, they did not illustrate the mechanisms which were commercially suitable. The patents which show the mechan-

isms used on these first looms, will not expire till 1912, or later. Attempts at competition before that time will be limited to mechanisms that will probably be much inferior to the mechanisms used by us in 1895.

Now we know of our own experience, that the loom we build and sell today is vastly better than that marketed in 1895. It is certainly worth much more than the difference between the price we charge and the price that any possible competitor could charge. By 1912, we shall undoubtedly have added further perfections, and made the distinction yet more clear. We shall promptly apply for protection from the courts if anyone attempts to duplicate our loom of 1895 before 1912.

If competitors build as good a loom as we sell and equip it with all our approved devices, they cannot sell at prices much lower than ours, **unless they are willing to lose money, or unless they can duplicate our large facilities and use our improved processes.** We confess to making satisfactory profits; but we make them by producing in great quantity, and by using every possible economy. The profit that is really due to the patent protection is less than that proportionately taken on any other important patented invention that we know of; in fact, **it is less than that often taken by manufacturers of machinery which has no patent protection and includes no patent or experimental expense.** The cotton machinery business is peculiar in its unreliability. The demands of the trade are so irregular that we are forced to provide plant and facilities for a maximum of orders, there being years when we run with half force, with general expenses undiminished. Competitors will have similar difficulties. They will also have to meet **our** competition; and it may not be assumed that we shall deliver any share of our business to others without something of a struggle.

It is not always wise for owners of important patents to try to outline their scope, since the courts retain that privilege; and the courts must be the final judicants. We may say that we believe **all** the important features of our loom to be controlled by patents, and we shall certainly assume that our patents **do** control them until the courts prove otherwise. We now have nearly 1000 loom patents available for use in litigation, the majority of which we own outright, the remainder being at our service for such use whenever necessary. The United States Government gives the introducers of inventions a chance to profit from their exclusive monopoly, for not less than 17 years. We shall endeavor to uphold the intentions of the Government by claiming the full limit for each and every one of our patents.

There may be instances in which some particular patent or other may be limited by disclosures in the prior art, or there may be proper differences of opinion as to just what its claims may cover. In such cases, we are perfectly willing to let the courts decide on the proper scope and interpretation, and we shall appeal to the courts for such decision whenever compelling circumstances arise. We have no envy of others' success; we have no desire to prevent outside inventors, or promoters, from profiting by their new and meritorious ideas; but we do resent attempts to profit from the work **which we ourselves have done**, and we shall use every legitimate means within our power to make such competition profitless for those who compete with us.

The fact that we have not been invariably successful in litigation hardly offers a chance for criticism, since we are not so cautious as to confine our attacks to the cases in which we must necessarily win. We are perfectly willing to take an even chance; we are also willing to take a **fighting** chance.

In our circular of November, 1897, we had a word to say to possible competitors, which still seems pertinent. We there-

fore reprint a portion as a few unfortunate experimenters failed to note its truth on first appearance :

"There are doubtless many bright men who will in the next few years give time and toil in the endeavor to evade the claims of our patents while producing similar mechanism. In view of the many other fields for inventive skill we ask—Is it worth the while? We are undoubtedly the first in the field and legitimately entitled to a fair reward for the expenditure of money, loss of time and consumption of brain energy. Our success is no vagary of chance or lucky stroke of fortune. Every step in advance has been gained after constant thought and experiment, with ten failures for every success. The patent office has recognized the novelty of our devices by broad basic claims. We have searched the records here and abroad, and have proof that we are pioneers in our line. We shall defend our rights in the courts with the obstinacy of conviction, if such methods are necessary. We have no wish for chance to show our strength. A lawsuit involves a waste of energy for one side at least, and an expense for both. We appreciate these facts after thirty years of continuous litigation."

"All mill men know that long bobbins weave off worse, especially in common shuttles where the bobbins are skewered on a spindle. It has been called to our attention that weavers in mills using these long bobbins on common looms, will not sometimes take the trouble to weave off a small amount of filling when it breaks near the lower end of the bobbin. They find it saves time to pocket such bobbins and use them at home to start the fire with. Of course, the loss to the mill is considerable, both in yarn and bobbins too. We would suggest that some of the mills who are trying the long bobbin experiment should keep the run of this item of loss, and see whether it does not counterbalance some of their supposed advantages."—[*Cotton Chats*, May, '05.

"We have called attention several times to the difficulty in properly boxing a large number of shuttles in shuttle-changing looms. The shuttles will necessarily vary somewhat, and when the box is set to receive the largest shuttle properly, the smaller shuttles will enter with less friction and receive more of a shock. It has been claimed that the shuttle-changing loom was vastly superior to the Northrop for cop-filling, but this bad boxing of shuttles is very liable to split cops; in fact, one of our experts noted some shuttle-changing cop looms where split cops were so numerous as to attract immediate attention. The weaver on these looms emphasized his disapproval by stating that it would take a 'hay-rake' to carry off the waste."—[*Cotton Chats*, July, '06.

LOOM MODELS.

WE DESIGNATE OUR DIFFERENT LOOM MODELS
AS FOLLOWS :

- A MODEL.—Like those sold in 1895 to the Queen City Mill, and other early customers.
 B MODEL.—Standard up to 1898.
 C MODEL.—Never put out.

Above models now obsolete.

- D MODEL.—First heavy pattern. (Now modified D.)
 E MODEL.—Standard, replacing the B Model.
 F MODEL.—Extra heavy pattern for 72 inch goods and wider, replaced by L Model.
 G MODEL.—A special pattern not to be duplicated.
 H MODEL.—Heavy pattern. Side-cam corduroy loom.
 I MODEL.—New construction for same goods as the E model.
 J MODEL.—Special light two-harness loom.
 K MODEL.—E Model widened to take 24 harness dobby.
 L MODEL.—New extra heavy wide Model.

While we have lettered twelve different models we do not illustrate them all, for some have been superseded, some are for too limited usage and some are unnecessary since other models have been revised to contain all their advantages. It is best for all concerned to limit the models so far as possible in order that a competent lot of fixers may be trained, and better for the same reason that there be no great multiplicity of devices operating for like purpose.

With this aim in view we present the modernized E Model

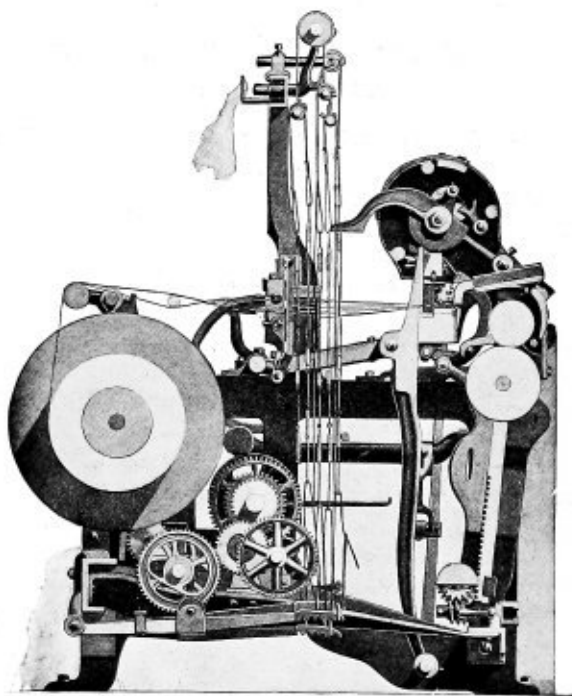

CROSS SECTION OF D MODEL LOOM.

No. 1 hopper, five harness, cotton harness, Roper warp-stop.

as our standard loom for all moderate widths and moderately heavy service. We find few customers who care for a special light loom for light weaves alone, preferring a style that has greater range of application. Our present E Model is heavier than the usual print or sheeting loom and can be used for a wide range of weaves. Since its early introduction it has received many improvements.

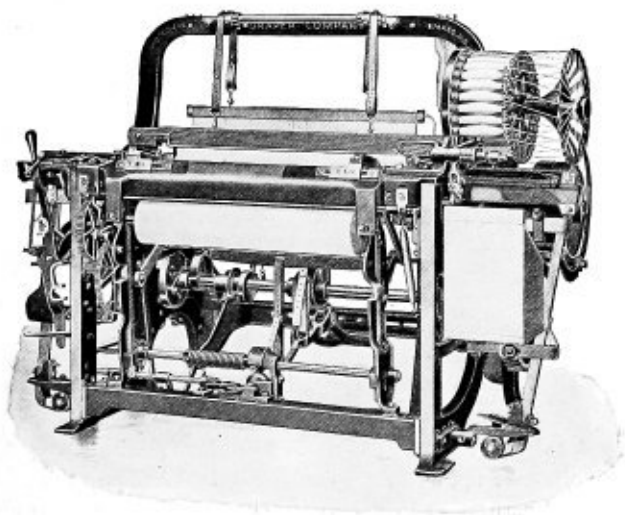

E MODEL.—AS BUILT IN 1901 AND LATER.

This is the regular standard type for general weaving used since 1898. It began to receive the large hopper, as per cut, in 1901. More looms have been sold of this model than any other that we have put out.

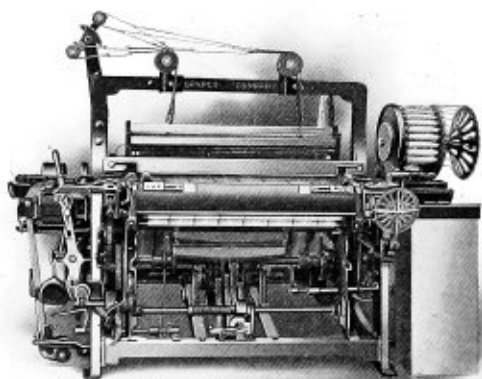

E MODEL OF 1907.

Cut shows 5 harness, wire heddle, loom, with Lacey top-rig, worm take-up, feeler and double fork. We equip this model with steel harness—2 to 5 harnesses; cotton harness ditto; common breast beam and low roll cut-motion if desired; special bag motion, centre selvage, measuring devices, pick counters and other special attachments if specified. Note new cast iron top for bobbin can, three part arch, Bolton loom seat, etc.

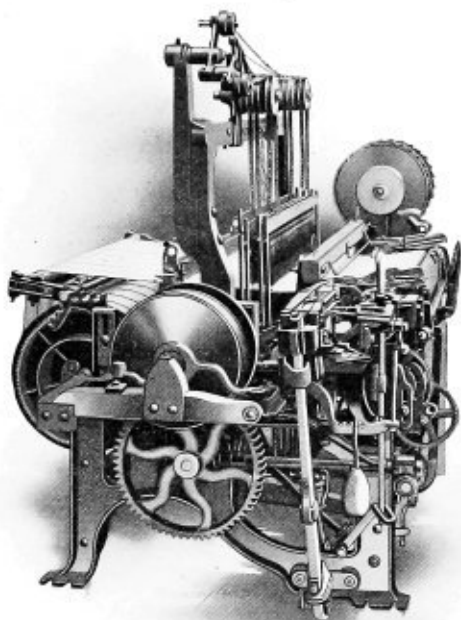

END VIEW OF E MODEL 1907 PATTERN.

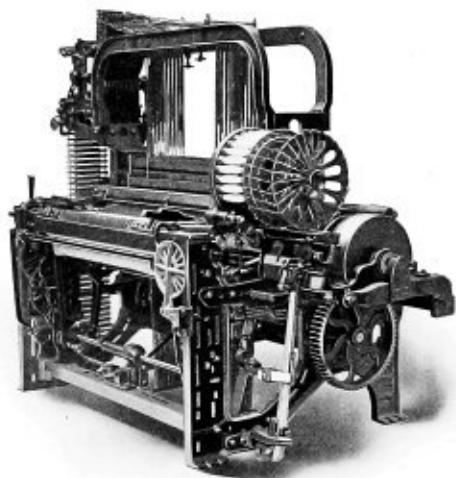

K MODEL.

Note the outside bearing for crank-shaft, double arch and dobby, etc. We have several thousand looms of this type in use, giving excellent satisfaction.

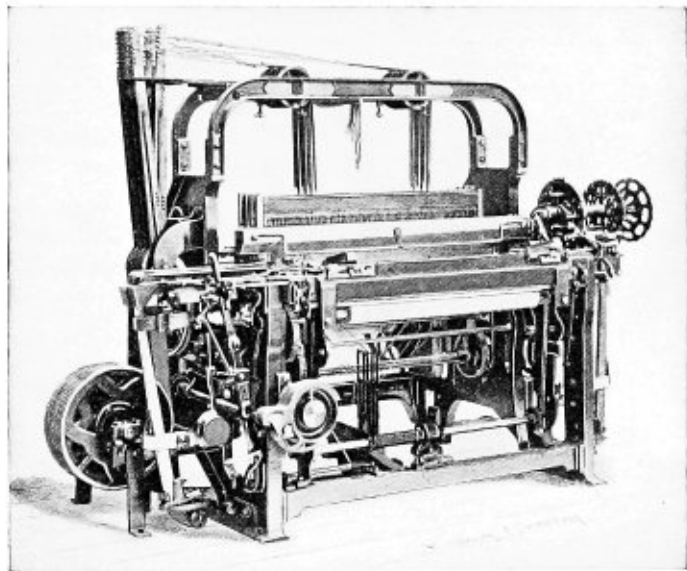

H MODEL, HEAVY SIDE CAM LOOM, 8 HARNESS.

This model has been used extensively and successfully on corduroy. We can furnish it with as many as twelve harnesses if desired.

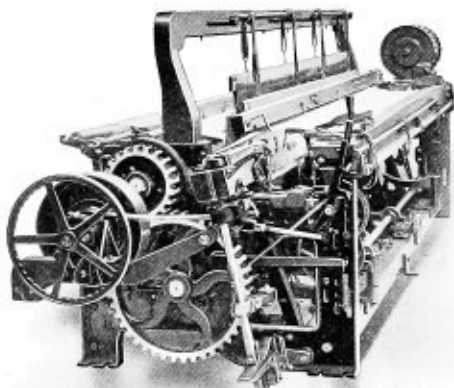

OUR "L" MODEL LOOM.

While we have had excellent success with the broad looms which we have already sold, we have felt that improvement was possible, especially in view of certain governing conditions. It seems quite important that a broad loom intended to replace old broad looms, should have the same floor space, and in this new design we have kept within the conventional limits. We build this model to weave cloth from 72 to 108 inches in width.

It will be noticed that we drive from an auxiliary shaft, with pulley geared to run at higher speed than the crank shaft, thereby producing great ease in operation; in fact, one observer said that it ran as easy as a 40 inch loom. We drive through a friction clutch pulley, and stop with a band brake, to which we call especial attention.

The pick motion on a broad loom requires careful study. We have made a long line of experiments on our rocker motion and shuttle box design with this end in view. We use a front binder on our broad looms exclusively, with long shuttle box and lengthened shuttle. When weaving two beams, we use a compensating, compound let-off. Our crank shaft is of great strength, being 2 1/4 inches in diameter. The lay and reed cap are also of extra strength. We apply an auxiliary shipper rod so that the weaver may stop or start the loom from the hopper end, without walking over to the shipper end. In broad loom weaving, this saves appreciable time. We have a new shipper mechanism which operates with great ease—one finger will move it. We also now apply swinging brackets or rests to assist in handling the large roll of cloth when removing same from the loom.

HOPPERS.

Our hopper, which is the heart of the filling-changer, has undergone quite an evolution since the first introduction of our loom. Our early No. 1 hopper is shown in several of the illustrations. The 25-bobbin hopper marked a noted advance, and the present spring-butt style will, we think, prove even more satisfactory. We have recently been introducing trial lots of an entirely novel hopper mechanism, which we think promises favorably, though which is not yet so fully tested as to become the standard equipment. While of the prevailing circular type, the bobbin tips are not held by springs, but the bobbin bases rather contact with coiled, spring-actuated pressing devices, on the theory that bobbins so held may be inserted with greater ease and held in greater security. The threading of the bob-

Our first
Large Hopper.
Holds twenty-
five extra bob-
bins. Is rotated
by reverse action
of transferrer.

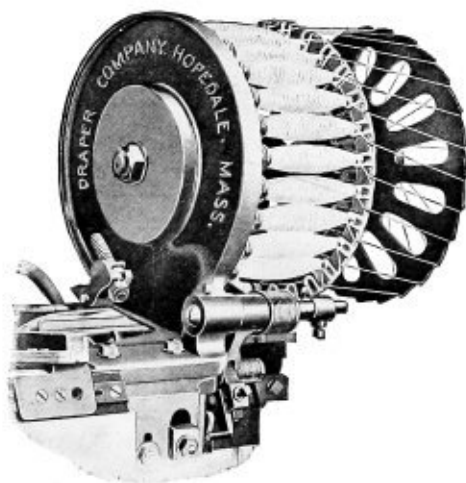
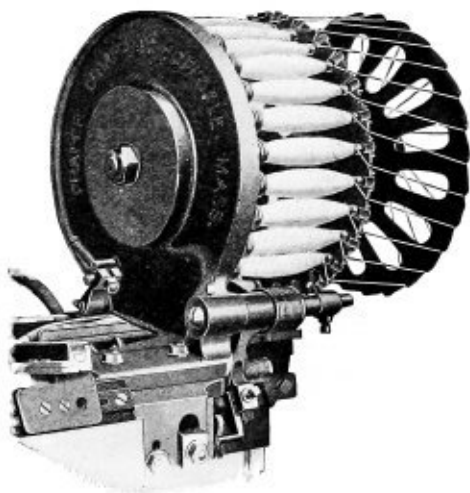

Second pattern
Large Hopper.
New end hold-
ers adapted for
either bobbins or
cop skewers. Also
new bobbin sup-
port, and thread
discs with wider
surfaces for thread
to bear against.

bins around the circles or discs, is easier, in that the threads lead naturally over a smooth bobbin tip disc, instead of having to be placed accurately at this point. Another novelty consists in the devices governing the bobbin on its way to the shuttle. We get entirely rid of the old rocking guide, which often gave trouble through catching and breaking. By turning a loom with the new hopper over by hand, and inserting a bobbin, it is at once noticed that the transfer occurs with far greater ease. With this hopper, we also apply an entirely new design of rotating mechanism, arranged so that wear will not cause back-lash. The stud on which the threads are wound is removable by hand for cleaning, the former bolt being cast solid in the end of a hand wrench, needing no extra wrench for operation. The transferrer is somewhat modified in construction. Several of the new features have already been tested on our regular pattern hopper.



NEW STYLE HOPPER.

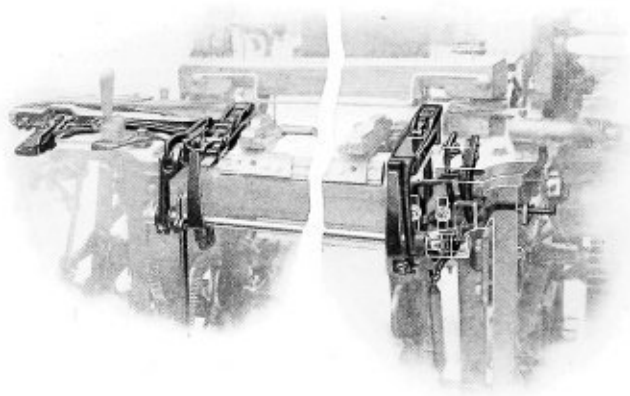

DOUBLE FORK AND FEELER COMBINATIONS.

Perfect cloth must be uniform in character, and secure from gaps and blemishes. Of course, absolute perfection is impossible, and various degrees of perfection are accepted in various classes of goods. We have tens of thousands of looms running, making commercially satisfactory goods with our common single fork loom; but in recognition of the necessity for better goods for other purposes, we supply different combinations as now specified.

Starting with the most elaborate and complex combination, we show our Feeler, Double Fork, and Feeler Thread-Cutter, in connection with the parts operating the transfer of filling from the hopper. The Feeler Thread-Cutter is always present with the Feeler, but the Double Fork is not a necessity.

Our feeler looms are all made so that they will allow the making of goods without mispicks by supplying filling just before exhaustion, stopping the loom for a break in the filling to allow the weaver to then match the pick, or they may be set to change the filling when it breaks and run the chance of a mispick at such times. With the mechanism above illustrated, the change for either purpose is possible through the moving of one piece of mechanism. When the feeler is used with the single fork, it might allow a slight thin place when the filling is changed on breakage of filling, so we use the double fork when the goods seem to demand extra care in the preventing of thin places.

The Feeler Thread-Cutter is a necessary evil, but we reduce its complication so far as possible by making it a part of our shuttle position detecting device. It may not be quite plain to all why an extra thread-cutter is necessary with a feeler mechanism, but on reflection it will be seen that a shuttle which ejects its bobbin before the filling is entirely woven, still carries the thread of that bobbin, and this thread must be cut or the shuttle may carry this same thread back into the cloth. The temple thread-cutter cannot take care of this special thread, since it is not in proper position. Were the temple thread-cutter set to engage this thread, it would also cut the running thread at every other pick. We have recently improved this feeler thread-cutter, by slight modifications which would not show in the illustration, but which do, however, greatly multiply its efficiency.

The Double Fork is very commonly used on our looms without the feeler, because the double fork not only affords a double protection against disorder, but it also has a double chance to control the take-up and prevent the slightest crack or thin place. The filling, of course, may break either going from or going to the hopper side of the loom. It may therefore call for a change of filling after having missed filling one shade, one shade

and a fraction, two shades, two shades and a fraction, or three full shades. One fork cannot possibly detect these variations.

We have greatly simplified the double fork construction since our earlier use. It is practically "fool-proof" at present, its only disadvantage being in the requiring of two inches extra width in the loom to weave the same width in the cloth.

The Feeler is intended for application with 2-shade goods where bunches from the end of filling are objectionable, but if sufficient care is taken with spinning, it ought not to be a necessity for the average run of fine goods. Many of our customers have ordered feelers on orders of looms for goods for which they thought them necessary, and afterward found the goods could be perfectly satisfactory without them. Feelers are often thought an essential on twills and drills, but the peculiar action of the single fork on 3-harness goods puts the new filling into the proper shed the majority of the time; in fact, quite as often as it is usually accomplished on common looms by average weavers. With the feeler, we can produce results impossible for a so-called "pick-matcher," which operates to hide the defect of an empty, or partially empty shed, by putting an extra thread into the same shed.

The feeler shown in the illustration is but one of several forms which we supply. We are aiming to reduce the amount of waste yarn on ejected bobbins so far as possible, and are certainly making marked progress in this line. To secure the best results from feelers, it is necessary to change the traverse motion on the spinning frame to wind a preliminary short traverse, or "bunch," as it is sometimes called, to thereby limit the amount of waste. The feeler is peculiarly adaptable to napped goods, where absence of filling shows very plainly. It is interesting to note that the British Patent Office has granted priority to our foundation feeler patent, recognizing it as the first effective device of its class.

BOBBINS.

It may not be generally known that we are now fully equipped to manufacture bobbins for our Northrop looms; in fact, have furnished them to the trade in large quantities for several months. The bobbins used with our looms are patented articles, and have always been sold directly by us to our customers, although manufactured for us elsewhere. We believe it better for our customers and ourselves to control the manufacture of this product so as to ensure more prompt filling of orders, and have personal knowledge of the difficulties which arise in meeting the conditions. We anticipated this course several years ago by buying large orders of bobbin blanks, so that we could have them properly seasoned in advance. We next decided to experiment in the line of using new and improved tools for the accurate cutting of the wood into shape, and we believe that our present plant is absolutely original in the methods employed. Most of the machinery has been built, or built over, in our own works. We intend to establish the highest possible reputation for these products, and shall spare no expense to arrive at this end. Poor bobbins make spindles vibrate, consume power, weaken the yarn spun and rise up on the spindles. Bobbins can not be made too well. We have arranged our seasoning so as to always have plenty of proper stock ahead of the machines. The illustration shows a few styles of bobbins now being manufactured, picked out at random from orders going through the department.

We have many additional contours to suit the wishes of customers, but those shown are approved by use.

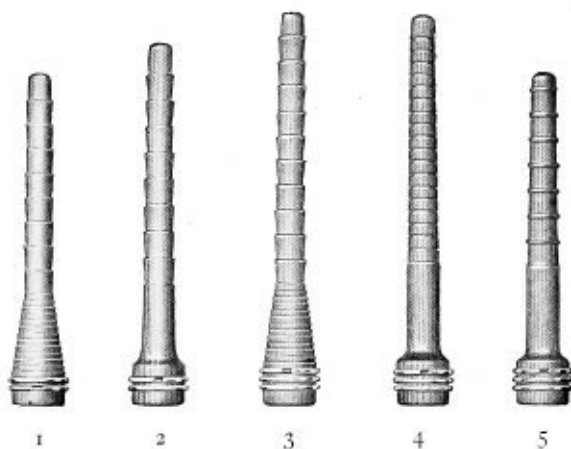

No. 1 represents a common form of short bobbin.
 No. 2 shows a longer bobbin with cylindrical base.
 No. 3 shows a yet longer pattern with 3 rings.
 Nos. 4 and 5 show different lengths and patterns of 3 ring bobbins, cylindrical base, for feeler looms.

We find 3 rings necessary on feeler bobbins to ensure a firm grip on the bobbin in the shuttle, which has to meet the contact of the feeler. Many of our customers are willing to pay the extra expense, \$1.50 per 1000, of having 3 rings on all bobbins.

Our bobbins and cop skewers are made in four lengths.

- | | | | | | | | | |
|----|-------|--------|------|-----|----------|----|-------|---------|
| 1. | 6 3-4 | inches | long | for | traverse | of | 5 1-2 | inches. |
| 2. | 7 3-8 | " | " | " | " | " | 6 1-8 | " |
| 3. | 8 | " | " | " | " | " | 6 3-4 | " |
| 4. | 8 3-4 | " | " | " | " | " | 7 1-4 | " |

The exteriors shown in the cuts are used on all four lengths.



SHUTTLES.

Our shuttles are usually desired in either of the two forms shown. That at the left is the older style with "Stimpson" eye. That at the right has the "Jonas Northrop" eye and is our regular recommendation. We use the same spring and cover with each.

The Stimpson eye shuttle happens to show a 4 notch spring. We make either shuttle with either 3 or 4 notches as desired.

We have special shuttles for special uses and when looms are ordered for such uses we select the shuttles to conform.



COP SKEWERS.

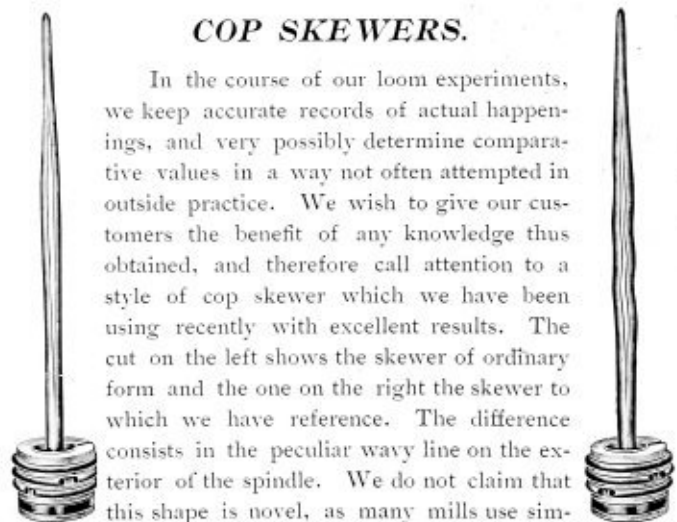

In the course of our loom experiments, we keep accurate records of actual happenings, and very possibly determine comparative values in a way not often attempted in outside practice. We wish to give our customers the benefit of any knowledge thus obtained, and therefore call attention to a style of cop skewer which we have been using recently with excellent results. The cut on the left shows the skewer of ordinary form and the one on the right the skewer to which we have reference. The difference consists in the peculiar wavy line on the exterior of the spindle. We do not claim that this shape is novel, as many mills use similar forms. We find that the cop waste on the new pattern is less than one-quarter of that with the regular skewer. We have to pay a slight advance for this extra process, but shall not make any difference in the price charged to customers. We have also improved our skewers by adding a flat band to the head below the rings to prolong wear.

Referring to another associate improvement we might mention that our cop hopper now has a neat device which prevents the rotation of the lower cop skewer in the hopper—a fault which sometimes causes the thread to wind around the skewer and break when the transfer of filling is made.

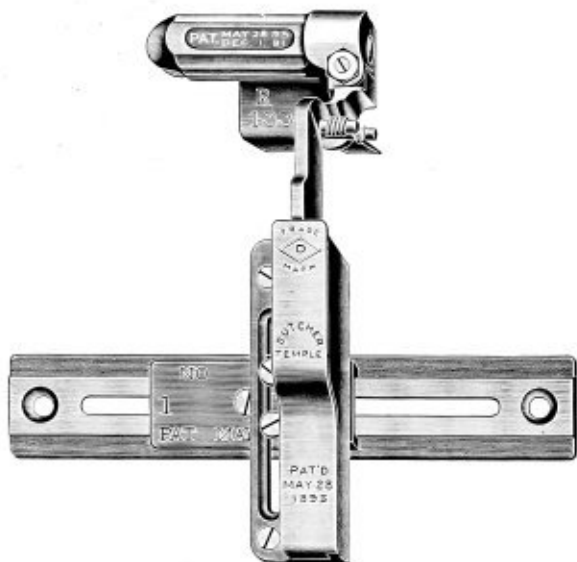

LATEST FORM OF THREAD-CUTTING TEMPLE.
NUMBER 133.

The cut shows our hump-cap style made with solid heel so that a loose heel will not bring extra strain on the cutter and cause the temple to be reciprocated through the cutter. It has extra capacity to retract so as to weave in a shuttle in front without damage.

We apply cutters to various forms of temple for special uses, adapting the pattern to the goods woven.

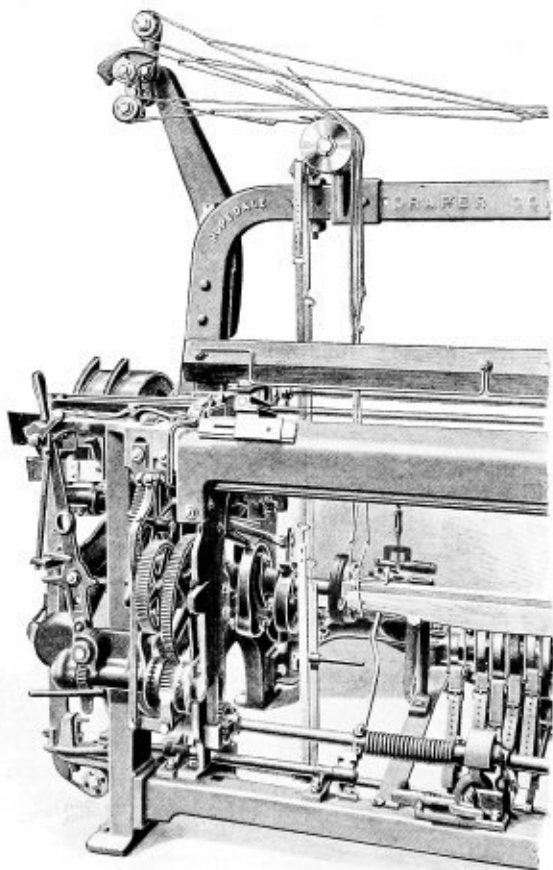

DETAIL OF LACEY TOP-RIG ON D MODEL.

We use this motion with both cotton and steel harness. Cut also shows our worm gear take-up with the let-back modification.

WARP STOP-MOTION.

Starting with a steel heddle mechanism for Print weaving we have branched out to include various types as here detailed. We are illustrating the present construction in each case showing certain novel attachments for the first time. All of our stopping mechanism operates from a cam on the lower shaft through a lever controlling the shipper. All of them include the use of serrated vibrating bars to engage dropped heddles or drops. The illustrations disclose the spring lock adjustment on the double steel harness jacks, the feeler-bar agitator to assist in finding the broken thread on the single-thread stop-motions and the new slack-thread controller for same in which a foot pedal throws the stopping devices out of operation temporarily to allow a slack thread to weave in, as it often will.

Our customers have by no means decided which class of stop-motion is superior. We have changed hundreds of looms from twine harness to steel harness and hundreds from steel harness to twine on exactly similar goods. The setting of the loom has so much to do with results, the heddles, or drops are often held liable for results over which they exert no control.

As seen on the next page our two shade steel harness motion has the heddles in each harness strung on two bars to allow greater freedom for knots to pass through. When using steel harness for three to five shades we employ the Lacey top or a spring governed top-motion as preferred. The double thread drops are used with an early type of stop-motion which is still preferred by many of our best customers. For some weaves a drop can act for more than two threads. In this cut is shown our release motion to prevent damage to the drop wires under repeated action of the feeler bar.

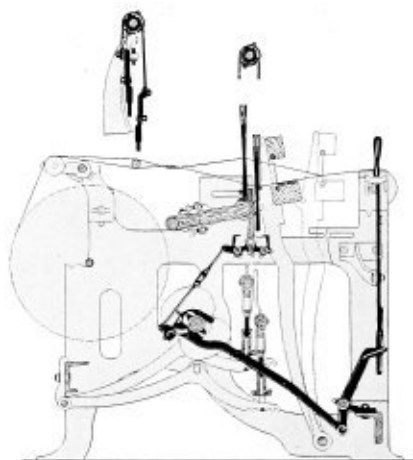

DOUBLE STEEL HARNESS.

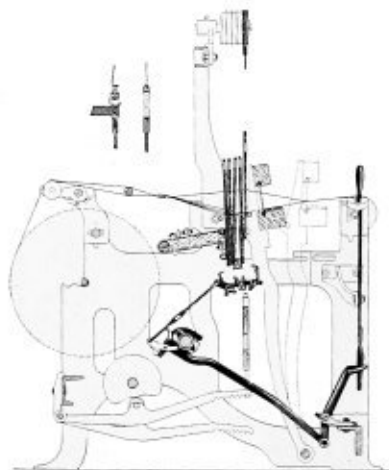

MULTIPLE STEEL HARNESS.

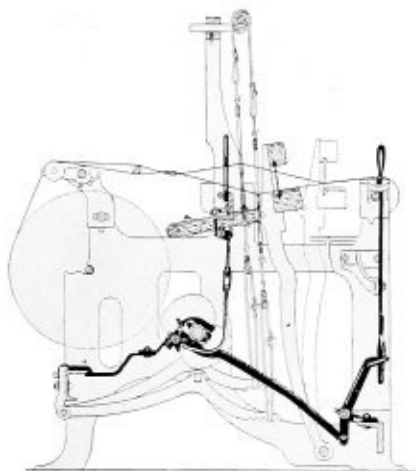

DOUBLE THREAD DROPS.

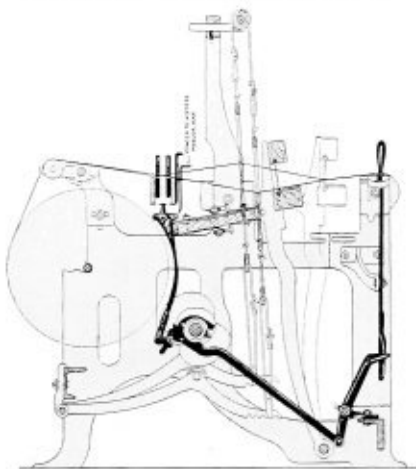

LEASING DROP WIRES.

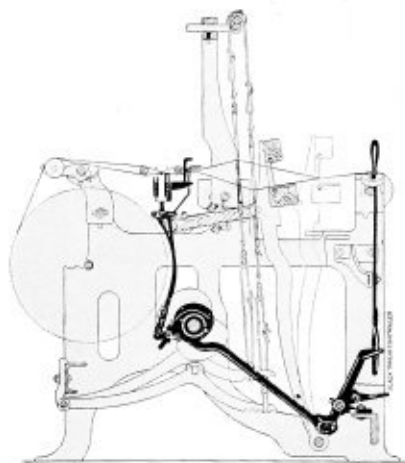

LIGHT PATTERN DROPS.

CUT-MOTION.

Although it might have been simpler to stick to standard designs in this line, copying from well known mechanisms, we have, as a matter of fact, given as much time to the Cut-Motion of the loom as any other separate feature. We started with a conventional pattern, but on finding that many of our customers desired to weave large rolls of cloth, we tried to design an arrangement which would wind any size roll desired up to 18 inches in diameter. We saw that the *High-Roll* arrangement of cut-motion seemed to offer marked advantages in this line, although the High-Roll had never gone into noticeable use in this country and was open to many objections in the forms commonly known abroad. Mr. Northrop devised our present standard construction with the exception of quite recent changes. We furnish low-roll take-ups when desired.

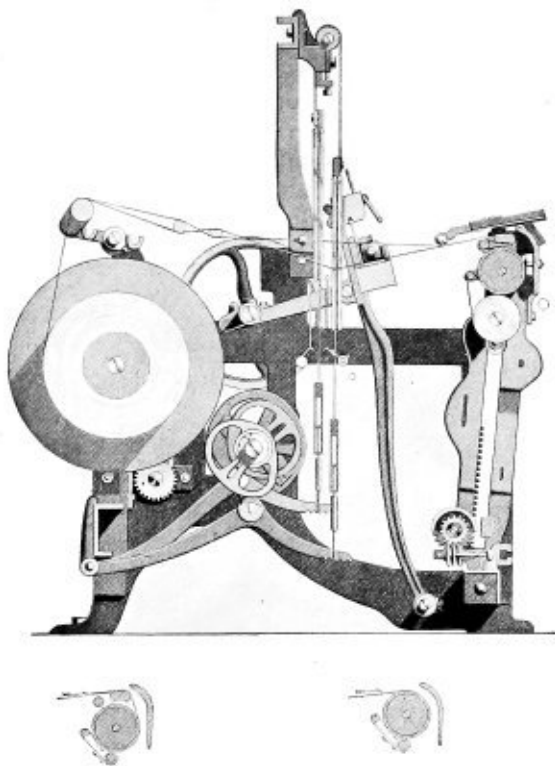

As will be noted in the cross-section of a Northrop loom, as shown in the cut, we have recently made a material modification in our Cut-Motion, in order to cover various requirements of weaving, it being found desirable in certain instances to have a greater length of cloth from the reed to the take-up roll than our former high-roll arrangement allowed. The lower cuts show two methods other than that in the cut above by which the cloth can be led to the roll.

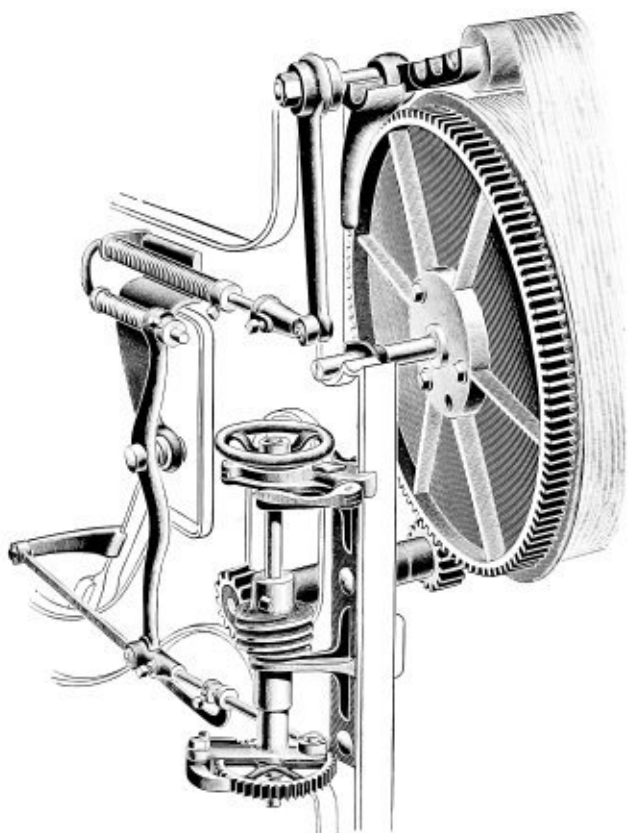

BARTLETT LET-OFF.

The Bartlett was our standard until the Draper-Roper let-off appeared. We owned the original Snell and Bartlett patent and sold over 50,000 of them for use on old and new looms before 1870.

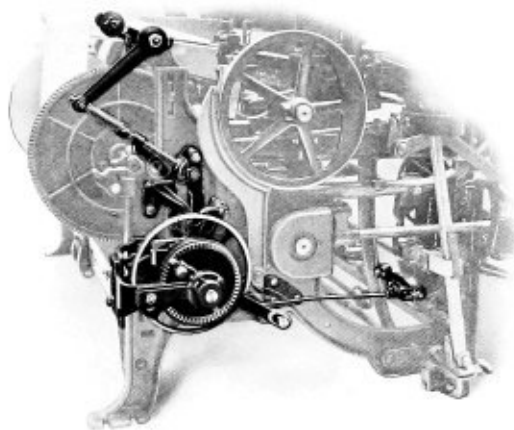

DRAPER-ROPER LET-OFF.

All let-off motions which are governed by the tension of the warp are manifestly affected in their action if the work of operating the letting-off devices increases. As the yarn weaves off the beam, and the diameter of the yarn circle on the beam grows less, the Bartlett and other let-offs of its class operate their controlling mechanism through less leverage, thereby bringing greater strain and counteracting the tension of the warp to just the extent of the increase. This requires a tighter warp to produce the same effect, and the extra tension on the warp narrows the cloth woven. The only way of counteracting this evil is to lessen the friction on the let-off, and for very accurate results the friction should be carefully adjusted at several periods during the weaving out of a beam. In attempting to perfect

let-off mechanism we have aimed to produce a device that should be fully automatic, using an even amount of strain by gradually changing the leverage as the let-off devices received greater motion. We therefore incorporated a follower or pressing-arm resting against the yarn on the beam and changing its position as the yarn circle varied. Change of position of this presser changed the fulcrum of the lever operating the let-off pawl, and practical tests have shown that we can weave with even tension, other conditions remaining the same. The let-off, of course, does not govern all conditions affecting width of cloth as this may be varied somewhat by the amount of moisture in the filling, the set of the pick, etc. By obviating the main difficulty, however, **we certainly produce much more uniform cloth than with any other competing device.**

We have profited by experiments with different gearing and have lately perfected the detail by providing an outside bearing and also by furnishing an ingenious hand-operated clutch by which the beam can be easily released for turning backwards or forward. We make no extra royalty charge for use of this let-off on our own loom, and do not apply it to looms of other make.

"The mill contains, at present, 25,000 ring spindles and 800 Northrop looms. All the cloth manufactured is for export, and consists of two kinds only, namely; China drills and sheetings or shirtings. Drills are 30 inches wide, weigh 3 yards to the pound, and have 68 ends and 48 picks to the inch. The sheetings are 36 inches wide, are of the same weight as the drills, and have 48 ends and 48 picks to the inch. In both cases the yarns are 13.65s twist and 13.80s weft, the cuts are 120 yards long, and the piece rate for weaving is 13 cents a cut. The rate for weaving similar drills in Maine, I had found but a few days before, to be 58 1-2 cents for 120 yards, and that was less than the Lancashire rate. Here, the cheapness of the Southern labor and the use of the Northrop loom has enabled the superintendent to under cut the Maine weaving price by 75 per cent. One man who was running 24 looms told me that he could earn \$1.35 per day; two other men were also running 24 looms each, and said they could make \$1.50, . . . the tacklers tend 100 looms each."—[*Correspondent of Manchester Guardian.*]

OUR COMMON LOOM.

We have at times filled several orders for common looms for parties who were not fully decided as to whether our mechanisms were applicable to their special kind of goods, with the idea that when we should have the necessary devices they could be attached to the looms. At the present time, however, our range of weaving is so broad that we rarely find a case where the common loom could be advised, and we foresee little future chance for their introduction.

Owing to our expensive experimenting and disregard for cost, we probably make the best common loom now in the market. Our common loom is simply our Northrop loom with the hopper and warp stop-motion left off and a slight change at the fork. With our make of loom it is, of course, guaranteed that our devices can be easily applied, while this is not always true of looms made by other builders.

We have given fully as much attention in late years to perfecting the conventional loom parts as we have to the betterment of our own additional devices. The common loom which we should furnish would, therefore, have all of our latest improvements in the line of let-off, take up, etc.

While we prefer to sell complete looms, we can apply our devices to certain models of old looms of others' manufacture. Such changing over is especially advisable where the common loom is too valuable to be discarded, as in the case of broad looms, dobbie looms, etc. We have changed over several thousand common looms with good results and have a special department for that work.

LOOM CONSTRUCTION.

In the early grouping of looms into twos, fours or other even numerals, it was found convenient to make them in rights and lefts, to save the weaver from taking extra steps in order to operate the necessary mechanisms. When we stretch a weaver over 16 to 24 looms, there is no possible advantage in having the looms of different hand. A mill can therefore buy our Northrop looms all made of one hand in every particular, if desired; in fact, we have filled one mill with looms of that description. If the looms are to go into an old mill where the pulleys and belt holes are already in position, it is often advisable to have a compromise in which the pulleys are placed on either side of the loom to accommodate the belts; but the belt is shifted from the left hand side of the loom **no matter how the pulleys are placed.** We have called such looms one-hand in former literature, which was not strictly accurate. We can see no reason why **new** mills should not have their looms **exactly alike**, avoiding all possible complication in repair parts.

It is well known that with the common looms as made for the trade in rights and lefts, there are many attending disadvantages. The patterns for one hand do not usually fit so well as those of the other, and the looms of one hand do not run so well as their opposites. The operative is forced to become ambidextrous, using either hand alternatively for effecting the same purpose. More skill is therefore required from the operative; in fact, it has often been proved that green help learn to operate Northrop looms much quicker than they could learn on common looms and this may be due, in part, to our one-hand system.

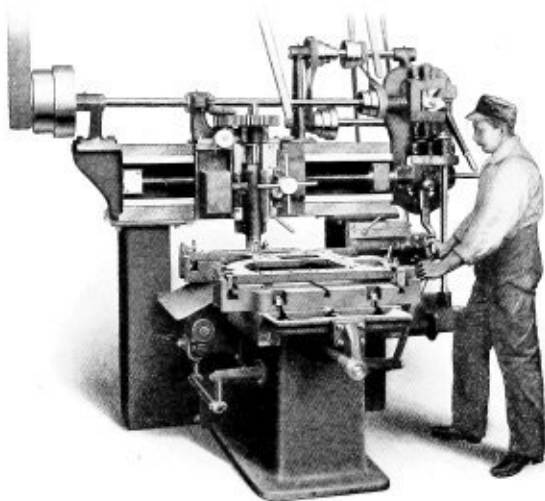

MILLING LOOM FRAMES.

The castings which are assembled into ordinary machinery, are a foundry product, and necessarily vary more or less in many important details. Difference in the heat of the melted metal, and variation in the rapidity of flow, and strains of cooling, are bound to warp and twist the finished product more or less, in spite of care. If we add to these reasons the differences intro-

duced by old foundry practice, in hand made molds with uniform patterns, the errors are necessarily multiplied. Our own foundry is equipped with the very best molding machines; in fact, they represent improvements designed in our own shops, and incorporated in trade machines through special arrangement. Our castings have won praise wherever they have gone, as we take particular pains in the selection and combination of different grades of iron to secure uniformity, and the very best possible results both in finish and adaptability to tool work. They are as good, if not better, than any made elsewhere, but still, **they are not good enough.**

Following the general American custom, we have built our looms for years by assembling the frame from the foundry castings, without machining either the sides or girts. In our aim to perfect our loom frame beyond the general practice of loom builders, we have recently introduced a full line of modern machine tools, especially designed for our own loom products. Each loom that we now send out has the sides carefully milled where other parts are attached, and the connecting girts are also milled to absolute uniformity in length. The cut shows one of our loom-side milling machines in operation. There are so many places to be cut that a considerable variety of motions is necessary. The machine for milling the girt ends is naturally more simple in detail. Our looms now approach a uniform standard of size and position of parts, and we expect that they will operate with uniformity and precision. Repair parts will naturally fit closer, and the whole machine has been raised into a higher class **by starting with a machined frame.**

We do not expect that builders of common looms will follow this practice; in fact, we would not advise them to do so. Any money spent in the further perfection of the common loom is practically wasted, for the present common loom is good enough for the few years of use ahead of it.

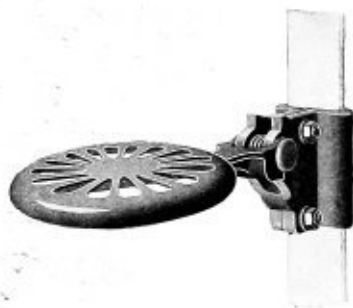

FIG. 1.



FIG. 2.

THE BOLTON LOOM-SEAT.

This novel attachment can be applied to any of our looms and is now sent out with all orders, one to each eight looms. It provides a seat for the operative that is normally held out of the way by a spring.

Fig. 1 shows the seat as held down by the weaver's weight. Fig. 2 shows it returned to position under control of its spring.

Mr. T. H. Rennie, Superintendent of the Graniteville Mfg. Co., wrote us he considered these seats an "*Indispensible adjunct to a well-regulated weave-room.*"

"An overseer recently called attention to a Northrop loom weaver, saying:—'You see that woman! She has gained 40 pounds since going on those looms and her last winter's clothes won't fit her.' Investigation showed that she formerly ran four common looms (No. 4s filling, 17 warp) and now ran twelve Northrop on the same goods. She was making better wages with less work, though ascribing some of the betterment in health to relief from sucking filling."—[*Cotton Chats*, Feb., '04.

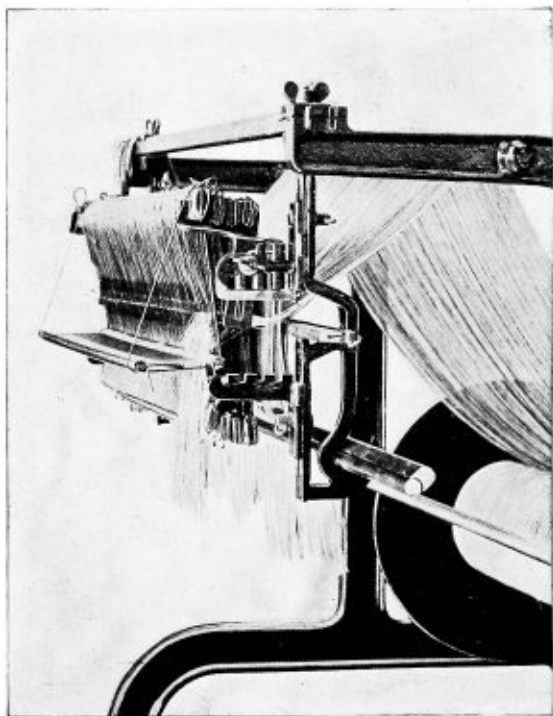

THE KEENE DRAWING-IN FRAME.

We are introducing a drawing-in frame with attachments, especially designed for holding the warp, drop wire detectors, harness, and reed in a new and convenient manner, to assist the operative in drawing in a large number of warp ends in a given time. There has been some objection to the use of warp stop-motions in that they caused extra expense for drawing-in; but this defect is largely obviated by this present invention. Its parts are adjustable, and have a range so that they are applicable to all our various forms of warp stop-motions.

SULLIVAN'S PATENT SHUTTLE GUARD.

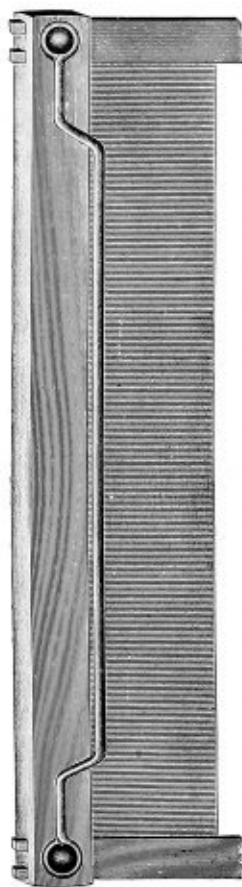

These Shuttle Guards are made of the best quality coppered wire, five-sixteenths of an inch in diameter, and are long enough to reach the entire length of the hand-rail. An eye is formed in each end, and these eyes fit over the bolts which attach the hand-rail to the swords. No other fastening is required, except for certain widths of looms, when a center support is added. The guard fits closely to the hand-rail for about three inches at each end and is then bent to hang over the race in any position desired.

This form of construction and attachment makes the most simple and durable shuttle-guard that has thus far been introduced.

The hand-rail is not cut or damaged in any way in making the attachment, nor are there any bolts, screws, or other fastening, such as have to be used with other guards, to work loose and annoy and hinder the weavers. There are no bolt ends projecting back of hand-rail to tear the harness. This guard can be applied for repairs where it would otherwise be necessary to re-

new the hand-rail, at less than half the cost of making and fitting a new hand-rail. There are thousands of them in use.



THE IMPROVED DURKIN THIN PLACE PREVENTER.

We applied thousands of these attachments to the old common looms before entering the loom field. Those who wish to get the best results out of their old looms when weaving light goods can use them to great advantage. They lessen thin and thick places, lessen the results of shuttle smashes, lessen warp breakage and increase production. We recommend them to purchasers of our Northrop Looms who intend to weave light goods on them. Every improvement that tends to lessen the breakage of warp threads is of high importance when endeavoring to increase the number of looms per operative. A slight extra cost at the start may pay for itself many times and not always receive due credit for the performance.

The construction consists of a pair of arms fastened to the usual bar across the loom which supports or forms the whip roll, and a roller held at its ends by the sliding bearings, noted in the cut by the open hole for the journal. Where Bartlett let-offs are in use the regular roll may be used without necessity for an additional warp roller.

In our first patterns there was difficulty at times in adjusting the tension of the spring to allow definite control of the movement of the whip roll. We have now overcome this trouble by using uniform spring tension and governing the movement by adjustable stops as shown. We make patterns to fit different styles of looms.

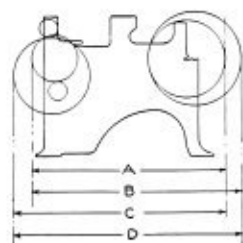
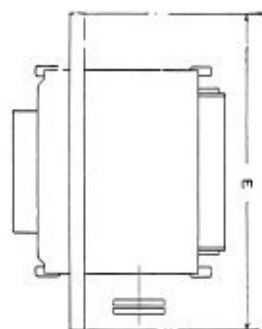

This diagram shows the space taken by an E model Northrop Loom.

Distance A is width with a full roll of cloth on low-roll take-up and 18 inch warp beam = 45 inches.

B-width with full roll of cloth on low-roll take-up and 20 inch warp beam = 48 inches.

C-width with full roll of cloth on high roll take-up and 18 inch warp beam = $47\frac{5}{16}$ inches.

D-width with full roll of cloth on high roll take-up and 20 inch warp beam = $50\frac{5}{16}$ inches.

E-width of lay on 28 inch single fork loom = $78\frac{1}{2}$ inches with 8 inch bobbin. Add two inches for every inch in name of loom. Thus 40 inch loom is 24 inches wider than 28 inch.

On many goods the cloth is never made into full rolls as shown on high-roll limit.

SPECIFICATIONS OF NORTHROP LOOMS

ORDERED FROM DRAPER COMPANY, HOPEDALE, MASS.

Make out separate specifications for each style and size of loom.

For..... Date ordered.....190.....

Address.....

Number..... Size..... Model.....

..... Right-Hand Belt from Above..... Left-Hand Belt from Above

..... Right-Hand Belt from Below..... Left-Hand Belt from Below

Kind of Cloth to be woven..... Width..... Sley.....

Number of Picks per inch..... Number of threads in Warp.....

NOTE:—We furnish one pick gear with each loom.

Number of Warp Yarn..... Number of Filling Yarn.....

Shall looms duplicate others in the mill?.....

If so, give date of previous order.....

Is filling on Bobbins or Cops?..... Total length of Bobbin or Cops.....

NOTE:—It is necessary to send several sample cops with mule spindle, or bobbin and spindle. Our regular sizes of bobbins take 5 1-2 inch traverse on a bobbin 6 3-4 inches long; 6 1-8 inches on a bobbin 7 3-8 inches long; 6 3-4 inches traverse on a bobbin 8 inches long and 7 1-2 inches traverse on a bobbin 8 3-4 inches long. Our regular cop sizes are 5 1-2, 6 1-8 and 6 3-4 Traverse. Bobbins are patented, and must be ordered through us. At least 200 per loom should be pro-

vided. When cops are used we send 30 skewers with each loom for large battery; 20 skewers with each loom for small battery. These are charged extra.

Shall we make Bobbin or Cop Heads Standard Butt?.....

Give largest diameter of full filling Bobbin or Cop measured on the Yarn.....

Large or Small Battery?..... Diameter of Spinning Ring?.....

NOTE:—Large Battery takes 25 bobbins or cops. Small battery takes 15 bobbins or cops.

What style of Take-up?.....

NOTE:—Our "High Roll" construction admits of winding any diameter Cloth Roll up to 17 inches. Embodied with this we have three separate styles of Take-up.

Our regular pattern takes up with every pick and lets back to prevent thin places.

Our Worm Take-up without the let-back feature, is a positive take-up, and is especially designed for corduroys, velvets and similar fabrics, which require 200 picks per inch and above.

Our Worm Take-up with let-back is designed for those who require a positive take-up and still desire the let-back feature.

What style of Let-off?.....

NOTE:—We furnish Roper, Bartlett, Friction, Roper and Friction, or Bartlett and Friction combined.

On "L" Model looms we furnish Compound Let-off and Compound with friction; on Corduroy looms we furnish a special let-off.

If friction Let-off shall we order Chain, Fibre, or Rope Friction?.....

What Whip Roll Combination?.....

NOTE:—Drag Rolls are used only for very heavy weaves; heavy denims and goods of this character.

We recommend for most cloths Plain Pipe Whip Rolls; for heavy weaves, not taking Drag Rolls, Vibrating Whip Rolls; for very light weaves, Durkin Thick and Thin Place Preventors. Unless Vibrating Whip Rolls, Thick and Thin Place Preventors or Drag Rolls are specified, we shall furnish with Plain Pipe Roll.

Will you have Feeler?.....

Will you have Single or Double Fork?

NOTE:—Double Fork Looms measure 2 inches more between loom sides than single fork.

Is filling for these looms to be made on new or old frames?

If new frames, call for Bunch Builders on specification for spinning frames and specify how many you want equipped.....

If old frames give maker of frames and how many Bunch Builders are wanted

NOTE:—When feeler is used an attachment on spinning frames, called the Bunch Builder, is required to wind bunch of yarn on bobbin.

What style Warp Stop-Motion is required?

NOTE:—We have three styles:

Steel harness using one steel heddle for every warp thread, adapted for 2-3-4 and 5 harness work.

Drop-wire Stop-motion for cotton harness, which requires one drop wire for every two warp threads in a two-harness loom adapted for 2-3-4 and 5 harness work.

Single Thread Lease-rod Stop-motion for cotton harness, using one drop wire for every warp thread. This stop-motion is adapted for any number of harnesses from 2 up.

Drop-wires and Heddles are extras and should be

ordered in sufficient quantities for extra drawing-in sets. It is well to order about 20 per cent. more drop-wires or heddles than the looms figure for this purpose.

How many Steel Heddles or Drop Wires?

How many looms arranged for 2 Harnesses?

How many looms arranged for 3 Harnesses?

How many up?

How many down?

How many looms arranged for 4 Harnesses?

How many up?

How many down?

How many looms arranged for 5 Harnesses?

How many up?

How many down?

What style Harness Motion?

NOTE:—We furnish the Roll and Shaft Top Harness-motion or the Lacey Top.

We adapt our looms to take the Crompton & Knowles Dobby.

We also furnish Special Side Cam Motion for Corduroys.

Are Cams on Cam Shaft or Auxiliary Shaft?

If auxiliary Shaft, shall we send gears to run 2-3-4-5 shade?

Single or Double Jack Hooks?

(Not used with Steel Harness.)

On what No. of Harnesses shall we set up looms?

How many up?

How many down?

Shall we supply Dobby?

How many harnesses?

What style?

Shall we supply Single or Double Spring Jack or Direct Springs?

Is Independent Selvage Motion required?

Plain or Tape?

What diameter and Face of Driving Pulley?

What width of Belt?

Tight and Loose or Friction Pulley?

NOTE:—Regular size 12 inches diameter, 2 1-4 inches face, for 28 inch loom. 14 inches diameter, 2 1-4 inches face, for 40 inch loom. We strongly recommend this width of face, as wider pulleys are much more troublesome in shifting belts.

For 2 1-2 inch belts and wider, we recommend friction pulleys.

We furnish 16 5-8 inch, 18 inch and 20 inch Beam Heads.

Which do you require?

NOTE:—When 20 inch heads are used looms measure 3 inches more in depth. Heads for our broad sheeting looms, are in all cases 16 inches.

Distance between Heads?

NOTE:—For proper width between Beam Heads, we recommend 4 inches more than size of loom. For those desiring extra space we supply Beams 5 1-2 inches wider than the size of the loom.

We furnish 5 inch and 6 inch diameter Yarn Beams. Which do you require?

NOTE:—We recommend 6 inch barrel for 20 inch Beam Heads, also with smaller heads if fine yarn.

How many extra Shuttles?.....(Only one per loom included without extra cost.)

What style Temple will you have, 1 3-4 or 2 1-2 Roll?

How many Bobbins shall we order for you?.....Style

Oil soaked

NOTE:—Send sample spindle to fit Bobbins to.

For what number of picks shall we set up looms?.....

Will you have Bolton Loom Seats?.....(One to each eight looms—no charge.)

NOTE:—Send us one complete reed such as you intend using on these looms. On order for 25 to 100 looms, 2

reeds, over this amount, 3. As the contraction on our High Roll Take-Up is considerably less on several classes of weaves than on other looms, it would be well to write us before ordering new reeds. The maximum reed space is 5 inches wider than the size of the loom.

Pickers must be of short pattern not projecting above shuttle box.

We furnish sample sets of strapping and pickers without extra charge.

On Side Cam looms send us copy of Chain Draft.

By what lines shall we ship?

Remarks.....

We find that several users of Northrop looms are buying wooden shuttle blanks cut to receive Northrop shuttle parts, from outside sources, taking parts from Northrop shuttles in which the wood is worn out to put in them. We call attention to the fact that we ourselves sell shuttle blanks cut to receive our parts, and charge a low price for the same, our regular charge for the ordinary Persimmon wooden blank being 25 cents each. We cannot see how anyone can afford to sell them for less and furnish a good article. There is not sufficient profit to ourselves in this price to make us very eager for the trade, but we do like to have our looms give good results, and we frankly do not believe that shuttle blanks made by other parties will hold our shuttle parts so uniformly in proper position as our own. If the bobbins in a Northrop shuttle are not centrally held they will break more filling. This might not be detected unless a careful comparison were made.

SOUTHERN SUPPLY OFFICE.

We have recently enlarged our Southern Supply department, consolidating our Southern office in the same building at 40 South Forsyth St., Atlanta, Ga. The Southern Supply Department was more or less of an experiment at the start, but has proved a great convenience to our customers. We intend to keep a full line of loom parts on hand, which can be furnished promptly to our customers, and by shipping from a point nearer to the Southern mill, we save them freight charges. There is a point, of course, at which shipments from the North are more advantageous, but our Southern Supply office handles the greater part of the business from the Carolinas down.

Since establishing this department, we have succeeded in converting many of our customers from the old habit of getting local castings for repairs. This use of crudely made parts on our machinery is distinctly disadvantageous to the user, and we, of course, can accept no responsibility for the proper running of our machinery, if parts are used which do not conform accurately to our own patterns. Where one of our parts is used as a pattern by which to get castings the new parts are necessarily imperfect on account of the shrink of the metal in the mould. We intend to keep our prices for supply parts so moderate that there is no profit to anyone in using substitutes, especially when the question of adaptability for the service intended is fitly considered.

"Green help learn to run Northrop looms with surprising quickness. A Southern example was heard from recently, who was given an 'acre of looms,' as he expressed it, about as soon as he set foot in the mill. When his first warp ran out he called to the fixer: 'Hey, mister, come here! the string's all run off that ar dam log.'"—[*Cotton Chats*, June, '05.

A NEW METHOD OF FILLING HOPPERS ON NORTHROP LOOMS.

In the early days of our loom introduction, we were told by many mill officials that the records which we were making in our own experimental room would be easily beaten after the mills had taken the looms under their own charge. This we were perfectly willing to concede, and results have proved that those who use the looms will discover many latent possibilities. We found that one mill was adopting a method of filling hoppers in which the weavers took a whole handful of bobbins from the filling box at one time, freeing the ends of filling from the bobbins with the other hand, winding off sufficient yarn, and then slipping all the bobbins into the hopper at one operation. This is made easy by the use of our latest hopper construction, having the new spring discs. Our investigator timed some of these weavers, and found they could put 24 bobbins into a hopper in a minute and a half to two minutes. The speed is facilitated, of course, by having the ends of filling left in proper position when doffing at the spinning frame. We estimate the time required to fill a hopper by the ordinary, single-bobbin method, at about three minutes.

The practical advantages of the system were shown by the results being obtained. The weavers were all running 20 looms on ticking, with no help. With common looms on similar goods, they run from 4 to 6 looms in the same mill, paying 32 cents per cut against 11 1-2 cents on the Northrop. The Northrop looms were also giving more production and better cloth, with less cost for repairs; in fact, the entire repairs, including shuttles, were not costing over 3 cents per loom per week. The matter struck us as having sufficient importance so that we

not only advised all our customers carefully about the advantages of the system, but we have hired expert weavers who understand the system, to teach weavers in various mills how to utilize the new idea. We naturally find more or less opposition from those who are set in their ways, and we also have found that other mills have made improvements of their own over the common system, some of the substitute plans having considerable merit.

A system which accustoms the weavers to placing several bobbins in the hopper at a time has another advantage, in that it uses up less of the weaver's energy in walking back and forth from loom to loom. Weavers are frequently seen putting bobbins in hoppers when there are only one or two gone. They should economize their effort by learning to wait until a large number of bobbins can be put into the hopper all at once. This latter system will allow them to tend many more looms with no increase of effort.

The fact that considerable time is taken by the weaver in finding the end of filling on the bobbin and unwinding the same has led to the suggestion that such ends could be unwound by cheap help who would arrange bobbins conveniently in the filling boxes before they were sent into the weave room.

ARRANGEMENT OF LOOMS.

We have given considerable study to the problem of arranging Northrop looms so that the weaver shall operate them with the least possible exertion. A great deal of a weaver's time and energy is taken in the moving from one loom to another. The usual weaver plans to get to every loom as it is stopped, so as to start it up as soon as possible, attending

to the duties of taking off cloth and putting bobbins in the hopper while all the looms are running. The problem was figured by taking the average distance a weaver would be obliged to go, by adding the distances from each loom to every other loom, and dividing by the product of the number of looms, multiplied by the number of looms minus one. On the single-alley system, the average distance for 16 print looms figured 19.23 feet. On a double-alley system, 16 looms, the average distance figured 15.82 feet, a saving of 17.7 per cent. With 24 looms the saving of the double-alley system is even greater, the average distance with single-alley being 29.52 and with double alley 21.19, or 28.2 per cent. saving. With a single-alley system, the average distance between looms increases directly as the number of looms; but with the double-alley system, while the looms are increased 50 per cent., the average distance from loom to loom is increased something like 35 per cent., showing it is easier for a weaver to run a given number of additional looms than it is to run an equal number of original looms. The two-alley system also allows the weaver to move in a circular path while filling batteries, and thus to be always approaching the batteries which need attention the most; whereas, in the single-alley system, when the weaver reaches the end of an alley, the loom needing attention is at the other end.

The problem was also considered in relation to arranging 24 looms in three alleys, eight to the alley. The average distance is practically the same as with two alleys, but there are disadvantages in having three separate alleys to move around in. With more than 24 looms there might be advantages in the three-alley system, but so far as our present experience goes, we are not prepared to give a definite recommendation. We do unhesitatingly recommend the two-alley system between the limits of 12 to 24 looms to the weaver unless the weavers' seat is used, when a long single-alley would be advisable.

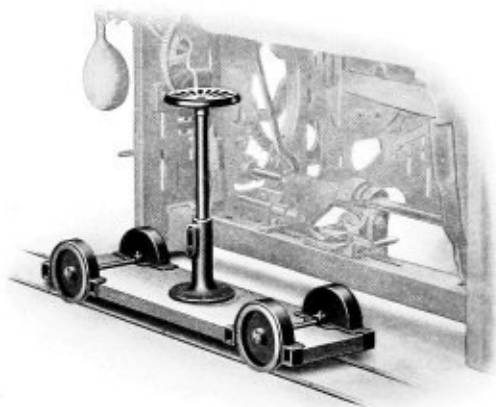

WEAVERS' SEAT.

While we have believed for several years that we should ultimately see good weavers running 50 Northrop looms each, it is possible that such a feat will not be generally accomplished unless some way is found to relieve the weaver from the extra exercise taken in covering so much of space. The actual hand operations necessary in running 50 Northrop looms are not beyond the capability of an expert weaver, if warps are well made and well sized. Neither are the operations of putting bobbins in hoppers, or drawing in warp, necessarily fatiguing. The walking now necessary and fatiguing can be practically eliminated by use of the seat illustrated in the cut. We sell these at ten dollars each, and five cents per running foot for each rail. The alley should not be too narrow and the help should not be allowed to push against the hoppers.

INSTRUCTIONS FOR RUNNING NORTHROP LOOMS.

Our experience is by no means sufficient to absolutely settle all points of discussion. We learn more about the art of weaving every week, and consider the possibilities of further knowledge and improvement practically exhaustless. Many volumes have already been written about the detail of plain weaving with common looms, so we shall limit these instructions to the new features introduced by the novel mechanisms on our own looms.

While these new devices necessarily introduce new problems, there is nothing very intricate about their operation. The fact that thousands have been running for years should give the Fixers self confidence.

BATTERY (OR HOPPER) ADJUST- MENT.

As the *battery* is thrown into operation either by the *left-hand filling-fork* or the *filling-feeler* according to the style of loom, in setting the battery it is necessary to begin with this fork or the feeler as the case may be.

If we first consider a loom without filling-feeler the various steps in the adjustment of the battery would be as follows: First see that the filling-fork is set properly relative to the *grate* or *grid*. Then place the end of the *filling-motion-finger* against the *filling-fork-slide* and tighten the finger on the *starting-rod* by means of the *set-screw* provided. Next turn the loom, allowing

the fork to engage with the *filling-motion-hook*, until the latter has moved as far forward as it will. This will turn the starting-rod into operative position, and the shuttle will now be on the battery side of the loom, in position to receive a fresh bobbin. Now raise the *feeler-finger*, which extends from the starting-rod beneath the *breast-beam*, until the *shuttle-feeler* can swing forward against a *stop* provided for it, and tighten it on the starting-rod in this position. Be sure and set the feeler-finger high enough so that the pull of the *starting-rod spring* will not prevent the shuttle-feeler from bearing against its stop. The *latch-depressor*, which is attached to the shuttle-feeler, should now be set so that the latch on the hopper will be struck by the *bunter* on the front of the lay. Bring the lay forward to the *front center*, thus causing the bunter to strike the latch and drive the bobbin into the shuttle. The shuttle should be in the center of the shuttle-box and when the *tip* of the shuttle is against the *picker* the *shuttle-spring* should be in line with the *heads* of the bobbins in the hopper. It is usually necessary to wrap a narrow piece of *leather* around the end of the lay to prevent the shuttle from going too far into the box, and on badly worn pickers it is customary to place additional pieces of leather inside this loop as required. If, now, the shuttle is in proper position the *transferrer* which inserts the bobbin should not touch the shuttle anywhere, and should be, approximately, in the center of the shuttle. If this is not true the proper position may be secured by turning the *eccentric pins*, in the *lay-swords*, upon which the *crank-arms* work. In doing this **be careful to turn the pins in both swords an equal amount**, so that the length of the *crank-arms* shall remain equal. If either *crank-arm* has become too short, from wear, to allow of this adjustment, it should be replaced by a new one. If the *head* of the transferrer comes in the center of the shuttle, but the *transferrer-fork* does not, the latter may be bent into place, but before doing this it is always

advisable to make sure that all adjustments have been properly made. The head of the transferrer should not quite touch the head of the bobbin when the former is at its lowest point, a clearance of not over 1-16 inch being desirable. This adjustment is obtained by means of the *set-screw* and *clamping-bolt* on the latch.

The shuttle-feeler will extend across the mouth of the shuttle-box, when the lay is in forward position and a bobbin is being transferred, and its end should come close to the *back box-plate*, but without touching it. If the shuttle is not in the box far enough to allow the shuttle-feeler to clear it, as the lay moves forward, the shuttle-feeler will be pushed back, and through the latch-depressor, the latch will be prevented from engaging with the bunter and a fresh bobbin will not be inserted in the shuttle. Thus the shuttle-feeler prevents the transfer of a bobbin from the hopper to the shuttle when the latter is not in the proper position to receive it, and **it should be always kept properly adjusted.** In the setting of this part a leeway of one notch in the shuttle-spring is allowed. That is, the bobbin transfer will take place when the shuttle-tip just clears the shuttle-feeler and does not push it back, and the latter is so set that when this occurs the first ring on the bobbin will go into the second notch in the shuttle-spring. If, however, the transfer is permitted by the shuttle-feeler, and the first bobbin-ring goes into the third notch in the spring, the shuttle-feeler is not close enough to the hopper and the *stand* which carries it will probably require filing to overcome the trouble.

The setting of the parts pertaining to the battery is slightly modified on feeler looms by the presence of the filling-feeler and the *feeler thread-cutter*, but many of the adjustments are not affected.

The movement of the starting-rod, on feeler looms, is transmitted from the *filling-cam follower* through the *feeler-slide*

and *starting-rod-arm*, instead of the filling-fork-slide and filling motion-finger as first described. The *filling-motion trip*, on the upper end of the cam-follower, should be set so that the notch in it would be in line with the end of the feeler-slide when the latter has been put into operative position by the filling-feeler, and they should engage one another just as the lay reaches the front center. The starting-rod will then be turned, and the shuttle-feeler and latch will be positioned the same as on non-feeler looms. The shuttle-feeler, however, will be made in the form of a *thread-cutter*, and the bunter on the lay is of special construction as it not only engages the latch but also operates the thread-cutter. The only difference which this makes in the setting of the shuttle-feeler is, that care must be taken so that it will both cut the thread at the proper time and prevent bobbin transfer when the shuttle is *not* properly placed. This can be readily done by raising or lowering the thread-cutter, or by slightly changing its angle to throw it further forward or back, as necessary.

A knowledge of the foregoing adjustments will be sufficient for any ordinary trouble not occasioned by breakage. The hopper, as a rule, gives very little trouble and requires scarcely any adjustment.

The rotation of the hopper should always bring a bobbin into proper position. The *bearings* should be kept properly oiled, care being taken not to drip oil on the bobbins. If the weavers leave *gaps* between bobbins when filling the hopper, they may have trouble. They should not allow these gaps to occur, as **it is perfectly easy to turn the hopper back and fill it properly.**

SHUTTLES.

The latest Northrop shuttle takes either bobbins or cops. It is shaped to prevent filling from throwing forward and escaping from the *eye*, or looping around the *horn*.

The *spring cover* at the rear is *inclined* so that if the shuttle is too far into the box, the bobbin, when striking the incline, can push the shuttle into place so that the bobbin can enter the spring properly.

If the *thread entrances* to the eye get jammed or closed they can be opened by knife blade, or other tool, but care should be taken not to open these entrances any wider than they were originally.

If the eye becomes clogged with cotton or lint, it should be cleaned out.

A small piece of *flannel* is placed at the throat of the shuttle for friction, which can be easily renewed. When coarse filling is used, it may be necessary to put bunches of *slasher-waste*, or *bristles*, through holes in the side of the shuttle, to make additional friction. These must be put in by the loom fixers, as we cannot send them out in this way, not knowing just what conditions arise in weaving.

If the *shuttle spring* gets loose, it should be tightened up by turning the *fastening screw*. **Shuttles should not be allowed to run with loose springs.** We believe we have made considerable improvement in this direction by our latest spring and fastening.

If trouble is found with *cut filling*, the wood near the shuttle eye may have become rough, and should be smoothed with fine sand paper, or emery. Any small slivers or sharp edges should be removed by the same means.

If warp threads should be broken out by the shuttle, it may be that the tips are blunt or rough, in which case the trouble may be remedied by polishing with emery cloth.

Outside of the usual splintering and slivering, generally caused by unfit wood, the actual breakage of shuttles on Northrop looms is probably due to the following causes:

The shuttle may get pinched between the *temple* and the *reed*, in case the *protector* fails to act. Our recent models of temples are designed to prevent breakage of the shuttle even if this happens, but of course, the fixer should follow up his work and **see that the protectors are properly operative.**

Shuttles have been split by bobbin rings wedging between the *spring grips*, but this is of rare occurrence. We grind the ends of our springs now, so as to limit the chance of their pressing against the shuttle sides. Of course, it is possible to break shuttles, if bobbins are caught during transfer, or if certain parts of the loom are broken or inoperative. In spite of all the chances, our shuttles wear very well, considering that one shuttle runs continuously, the wear not being divided between two shuttles, as in the common loom.

We furnished all the shuttles used with our looms, until a few of our customers tried the experiment of buying wooden blanks for use with old parts from our shuttles, so have an actual record of their life, which runs over, rather than under, six months on the average. Remember that our shuttles run continuously and undergo twice the wear in the same time as common loom shuttles. Excessive wear is often due to *sharp reeds*.

Shuttle wood is liable to curious variations, both from natural and artificial causes. Sometimes the stock is too severely *kiln-dried*, taking all the life out of the wood so that it breaks like sealing wax. Shuttles are sometimes treated with hot solutions of wax or oil. This may improve the surface smoothness, but if not carefully followed up, may injure the stock.

Shuttles are shaped to run true and balance as well as possible. With the weight continually changing and shifting, as the yarn weaves off, it is impossible to keep the center of gravity in a uniform position. The shuttle is also pulled out of place by the drag of the yarn, which varies in tension as the bobbin or cop winds off.

A perfect design would have the shuttle points on a line that would pass through the center of gravity, with the weight fairly well distributed on each side of the centre.

Shuttles made for *front-binder looms* have a longer back, so that the pressure of the binder in its last contact will not change the direction of the shuttle. We made all our looms with *back binders* for years, but are now having very good success with front binders on certain models.

MISTREADING.

By this is meant a failure of the shuttle to thread-up properly after the insertion of a fresh bobbin, and for convenience we may classify these failures as *real* and *hopper-mistreads*. A real misthread is one for which the shuttle-eye is responsible, the thread in this case breaking after the shuttle has gone once across the loom, and a hopper misthread is one due to breakage of the filling when the bobbin is being transferred from the hopper to the shuttle. The real misthread is the much more serious of the two as it causes a *mispick* (or shuttle mark) in the cloth, and several real mistreads in succession will result in a defect which may necessitate cutting the cloth at that point. The usual cause of real mistreads is a damaged or *clogged up* shuttle-eye.

The shuttle-eye may possibly get jammed or choked by lint

so that the thread cannot enter at all. If this happens, the fork will still be raised all right, for the thread will draw over the top of the shuttle on its first flight. When the shuttle is picked back, however, the thread will be broken, calling for a new transfer of filling and making the above mentioned defect in the cloth, as the shuttle will continue to lay threads going from the hopper and will lay none on the return. In weaving *two-shade* goods this action puts *several threads* in one shade. It may continue this operation until all the bobbins have been transferred from the hopper when the loom will be stopped by the *hopper misthread device*. A hopper misthread causes no defect in the cloth, and, moreover, we now provide our looms with the device just mentioned, which will stop the loom if two such misthreads occur in succession. This device will also stop the loom if for any reason the *left-hand filling-fork-slide* is moved forward three times in succession. It may be possible for the fixer or the weaver to intentionally disarrange this motion so as to prevent the looms from stopping, but this should not be allowed, as it might cause a bad *thin place* if the hopper became exhausted or any accident caused repeated misthreading. The fact that the loom is found stopped, even when there is not a warp break or slack thread, does not necessarily mean that the shuttle has been misthreading. It is possible that the shuttle-feeler may have prevented the shuttle from receiving a bobbin twice in succession, because of the shuttle being out of its proper position and this would cause the loom to stop just the same as if hopper misthreads had occurred twice running. If the loom is found stopped with an empty bobbin in the shuttle it is a sure sign that the shuttle-feeler has found the shuttle out of place, and this means that **the shuttle is not boxing properly.**

Men with inventive capacity often assume to improve on our shuttle eye, and we do not assume that improvement is not possible where we have made so many changes ourselves. It is

necessary, however, to recognize the requirements of the case, as a shuttle eye for universal use must be adapted not only for threading easily, but also prevent the filling from throwing ahead and getting out of the slot. It must also provide for easy passage of bunches, be practically self cleaning, give a proper friction, not weaken the wood materially, have sufficient weight to balance the metal parts at the other end, be fitted in the wood so as not to catch warp or filling, and be designed for easy molding and machine work. As to the simple problem of threading shuttles, as far back as 1894 we could transfer over 1,000 bobbins without a misthread. These records cannot be attained, however, without proper setting of the loom. We believe the boxing of the shuttle has more to do with this trouble than anything else, and recommend a *light, easy pick* with moderate pressure of the binder. We learned years ago that the amount of misthreading was affected by the moisture in the weave room. Yarn is strengthened by moisture and strong yarn will naturally break less under strain whether it is filling or warp.

BREAKING OF FILLING.

Every break in the filling causes extra labor, as the weaver must put a bobbin in the hopper twice at least in order to have its supply of filling woven off, or if the loom has a feeler it will stop, and the weaver must match the pick and again start it, which causes a loss in production. Every bobbin ought to weave off clean, except on feeler looms, but a harsh pick may cause the filling to *throw out of the shuttle eye or loop around it*. Sometimes the yarn *wraps around the point* of the bobbin or skewer while running off, and the filling sometimes catches on the picker or picker stick. Care should be taken to allow no

cracks, projections, or corners where the thread may catch when throwing out of the shuttle. With our earlier shuttles we expected breakage with No. 36 filling on at least one in ten bobbins, whereas we do not now expect more than one in twenty-five. It is easy to note how filling is running by casually glancing at the hoppers in the weave room to see how many partly filled bobbins have been put back in the hoppers. With cop filling the yarn sometimes catches in the slot of the skewer. Also trouble is occasioned by *split cops*, due either to shock in the shuttle box or poor design of spindle or skewer. This fault can be largely decreased by properly setting the pick and the use of proper *shuttle checks*. There are many checks in the market which box the shuttle properly, but a shuttle must be received *easily* to prevent cop splitting, and there are very few checks which are adapted to this requirement and also to controlling the shuttle properly.

BOBBINS.

We have received a long and varied education in the requirement of filling bobbins as we have purchased or manufactured all of those used on our Northrop Looms ever since we commenced to build them. The complaints of our customers therefore all pass through our own office. Bobbin wood is liable to serious fluctuation, especially when not *carefully selected* and *carefully dried*. We believe the greater part of the trouble with bobbins getting out of shape is due to *short seasoning*, it being necessary to carry a very large stock of blanks in order to have sufficient supply of thoroughly seasoned wood on hand. Changes in the wood itself not only require *reaming* and the weeding out of badly warped bobbins, but also cause *loosening of the rings*

before the bobbins are otherwise worn out. It is, of course, necessary for our loom that the bobbin rings should hold firmly so that the bobbin will lie properly in the shuttle. We insist on careful gauging of both wood and rings at the start, but the wood may change after the gauging process. The split rings applied to the bobbins are necessarily somewhat elliptical. In order to obviate trouble from this source the rings are applied so that the slots will not be opposite each other. The bobbins will swell if filling is dampened so that they will not fit the spindles. This necessitates reaming, but the reaming should not be done while the bobbins are wet, as too much wood will then be removed. We are now introducing spindles with a *centrifugal clutch* that allows a loose fit with the bobbin on the clutch and allows more leeway for the fit. We believe this is one of the most important improvements ever made in the art. The contour of the bobbin varies with the kind of yarn spun. Bobbins for *coarse* filling require *coarser steps* on the *conc.* With coarse yarn we use 12 steps, for print yarn 14. For coarse filling we usually recommend *grooves* on the barrel instead of *ribs*. We have made careful experiments in order to determine the proper size of barrel for filling bobbins, and our standard patterns are all of uniform diameter. To avoid trouble with damp filling we advise that the bobbins be *filled with linseed oil* and two coats of shellac applied after they are dried. Much trouble is found with filling yarn because the bobbins do not fit down properly on the spindles. We expect to obviate this trouble entirely with our new spindle, but the fault will necessarily continue in old mills. With the old pattern of spindle the bobbins should fit the *sleeve* at from one-half to five-eighths of an inch, entering the *cup* (if there be one) at about one-eighth of an inch, fitting loose at the *upper bearing*, which should be at least $\frac{3}{4}$ of an inch in length. Cups are really not necessary on our filling bobbins as the steel rings prevent splitting.

When the bobbins are reamed the reamer should be carefully watched. Not over 500 bobbins should be reamed without testing the fit. Try the spindle in the bobbin and feel if there is play at the upper bearing. If not, the reamer needs *spreading*. To spread and sharpen a reamer, the *temper* must be *drawn*, the reamer placed in a vice and the part that reams slightly spread with a light hammer and a tool made for that purpose. The reamer must then be tempered. Any good mechanic can change the reamer to the proper size. A mill with 10,000 filling bobbins should have at least six top reamers and two "pod" reamers. The upper bearing gives a great deal more trouble than the lower bearing and it is well to have a surplus. Run the reamer at least 2,000 revolutions a minute,—2,500 is better. A good man should ream from 7,000 to 10,000 bobbins a day. Every mill should have at least 20 bobbins to a spindle to each number of yarn used. To weave off in the shuttle properly the *filling wind* should be considered. We have found many mills where changes in the *traverse* would give better results.

PREVENTING BUNCHES IN CLOTH.

All weavers know that when the last end of filling winds off from a bobbin it is liable to make a *bunch* in the cloth. Careful investigation has determined that these bunches are practically always due to the bobbins **which did not start up properly** after doffing and therefore require to be wound on by hand a few turns in order to piece up. These few turns are not wound tight enough to wind off properly and very possibly all come off together, which accounts for the fault noted. There is a common method of doffing which also aggravates this difficulty, when the doffers wind the yarn on the bobbins by giving it a few

twists around the base instead of using the *socket doff*. The socket doff is certainly preferable. In order to avoid the trouble from the bunch with the bobbins not starting properly, Mr. Charles H. Arnold of Grosvenor Dale, Conn., designed a method in which the doffers are provided with bobbins having sufficient yarn spun on them so that they can be pieced up. Whenever an end does not start in doffing, the doffer removes the empty bobbin and *replaces* it with the bobbin already provided with enough yarn to piece up. In the weaving of fine goods this change reduces the seconds at once to a marked degree. The extra bobbins are of course furnished by spinning a slight amount of yarn on some extra bobbins at the frame and then removing them for use as noted. It is, of course, somewhat difficult to secure co-operation between the two departments, the spinner not often willing to go to extra work on the weaver's account. It is only, however, in this way that good results are obtained. Mr. Arnold's idea is patented, but we allow its free use to all owners of Northrop Looms.

The bunches can also be entirely obviated by use of the Feeler which will supply new filling before the end has run off the bobbin. We have put feelers on hundreds of looms for this special effect.

COP LOOMS.

In weaving with cop filling more care is necessary than with bobbins. Our skewers are made from conventional patterns by an experienced builder and are designed to fit the sample cops which are sent us. We have to fit the skewers to the cops, as it will not do to assume that all cops are alike because they are spun on similar mule spindles. Some yarn is twisted

harder than others and yarn is often spun both coarse and fine on the same spindle. Proper temper is very important, as the skewer should not only have the proper shape, but hold it and stay open. Many fixers spread skewers with a screw-driver or other tool, but this is very liable to break them. When a mill uses *steamed cops* it should be careful to send us sample cops after being steamed. Trouble with cops splitting is not necessarily due to improper shape of skewer or excessive pick at the loom. It may possibly be due to the lack of proper wind in the spinning room. Sometimes cop skewers on our looms get bent by catching in the shuttle. They should be carefully examined at intervals to see that they are perfectly true. During the transfer the empty skewer strikes into the box with something of a blow and the *cop tubes* which are removed from the skewers can be dropped in the box to make a cushion.

WARP STOP-MOTIONS. THE STEEL HARNES.

With our *steel harness warp stop-motion* the *heddles* themselves are used as detectors to effect the stopping of the loom if a warp thread breaks or becomes too slack. Originally we only applied the steel harness for two-harness weaving, but are now using it for three, four and five-shade work with success in a number of mills. The *heddles* of the steel harness are suspended by the *heddle bars* which pass through *slots* in the upper part of the *heddles*, the warp threads being drawn through the *eyes* near the center. The lower ends of the *heddles* are free from the moving frame, but are guided by stationary devices which prevent their swaying too much either forward or sideways. Between the harnesses is a long, flat casting called the

stop-motion girt, which serves two purposes; first, to separate the harnesses and hold them in position, and second, to resist the action of the *feeler bar* when a heddle drops down and is caught between it and the *girt*, as happens when a warp thread breaks. On the lower edge of this *girt* is fastened a strip of sheet steel having serrated edges, which we call the *serrated bar*. The *edges* of the feeler bars are also serrated, and this construction prevents the heddles from slipping or twisting when engaged by the feeler bars.

Upon the *cam shaft* is the *oscillator cam* upon which the *oscillator-cam-follower* works, which, through the *oscillator rod*, operates the *feeler bars*. This cam follower is held against the cam by means of the *oscillator spring*. Adjacent to this cam, and forming a part of the same casting, are two *projections*. Normally, these projections just clear the *knock-off*, which is a small casting fastened to the same stud or shaft that holds the cam follower. When the heddle drops, the feeler bar strikes it, and the cam follower is thus prevented from following the cam, and the knock-off, on the shaft with the follower, is moved out of its normal position in such a way as to be struck by one of the projections attached to the cam, thus moving the *knock-off link* on which the cam follower and the knock-off are mounted. This motion of the link is communicated to the *shipper handle*, throwing off the belt. When no heddle is down the feeler bars oscillate back and forth, and keep the knock-off out of the way of the projections or *lugs* on the hub of the *oscillator cam*, and the loom continues running.

In setting the steel harness stop-motion the first thing to do is to either throw off the belt, or remove the *key* which holds the end of the *shipper-lever* in the *shipper-handle* (the latter can now be done on all looms which we make), and place the shipper handle in the *notch* in the *shipper-lock*; this will bring the stop-motion parts into the same position as when the loom is

running. Then turn the loom until the feeler-bars are in their extreme forward position under the girt. The knock-off link should be against its bearing in the hub of the cam, and the cam-follower should bear against the cam in its lowest place. The small casting on the same stud as the cam-follower, called the *knock-off*, should be so set that it will just clear the projections on the hub of the cam as the cam revolves on the cam-shaft.

The cam on this stop-motion is very similar to that used with the cotton harness stop-motion. The position of the oscillator-cam is governed by the setting of the harness cams and should work in conjunction with them. When the harnesses are level, or passing each other, the oscillator cam should be so set that the long axis of the cam is horizontal, that is, so that the faces of the cam point directly to the front and back of the loom on a line parallel with the floor.

The cam-follower is held in position by a *spring* on the *stud* to which it is fastened; if it does not follow the cam as quickly as it should, tighten this spring. Care should be taken, however, **not to have too much tension on this spring**, but just enough to make the cam-follower work properly; otherwise the heddles may be bent by the force of the blow. The motion of this cam-follower is communicated to the feeler-shaft by means of the *oscillator-rod*, the length of which may be varied at will by means of the *oscillator-rod-coupling*.

On each side of the stop-motion girt, under the warp and just touching it, are the front and back *rods*, which hold the heddles in place so they will drop into position to be caught by the feeler-bar if a thread breaks. These rods also hold up slack threads which otherwise might allow the heddles to drop low enough to stop the loom.

Small castings called *heddle-bar collars* are placed on the heddle bars to keep the heddles in line with the yarn. There

is also a *heddle-box-block* at each end of the stop-motion girt to keep the bottom part of the heddles in line.

The harnesses are allowed to cross at various positions of the crank, on *underthrow* looms from the bottom center to the front center, and on *overthrow* looms from the top center to the front center, according to the class of goods to be woven.

On two-shade looms the harnesses are connected to what are termed *harness-rolls* at the top of the loom. Care should be used to have the *back* harness connected with the *larger* roll, and the *front* harness to the *smaller* roll, in order to work in harmony with the harness cams. The opposite to this has sometimes been done, thus interfering with the proper working of the loom.

The *front* heddle bars are smaller than the *back* bars, and must be set in their proper position.

The front and back rods should be set just high enough to touch the yarn when the yarn is in its proper position on the race-plate.

If the shade should be too high above the race-plate it can be lowered by turning down the *set screws* in the castings, at each side of the loom, upon which the *harness-roll-shaft* rests, and then tightening the connection between the *harness-yoke* and *treadle*. To do this, raise the *cap* having the *spring* on top and turn it. If the shade should be too low, loosen the connection between the harness-yoke and treadle and raise the harness. The shade should just clear the race-plate. A great advantage with the steel harness is, that after the shade is once set it requires very little or no attention, and new warps can be put in without altering the shade, and more quickly than with any other harness made. In putting in a warp, however, it is possible to get it tangled up; but this can be avoided by a little care and common sense on the part of the operative. After the warp is once placed in the loom there is no danger of tangling.

The *bottom connection* of the front harness should be placed in the *second notch* in the treadle and the *back one* in the *fourth notch*.

The heddle-bars must be straight. If the heddles bind in any way on the heddle-bar it will cause reedy cloth, and also be a serious strain on the yarn. No oil should be put on the heddles or heddle bars.

It sometimes becomes necessary to apply a heddle to the harness after the warp has been drawn in, and this is usually done by *breaking open* the slot and slipping it onto the bar. While this is all right as a temporary expedient, it is well to go over the harnesses in the drawing-in room before re-drawing, and remove such heddles, as they are liable to catch in adjacent heddles, and interfere with the proper action of the warp stop-motion.

One of the most annoying troubles formerly experienced with our steel harness looms was due to the liability of the heddles to become *magnetized*, thereby causing them to stick together and make poor sheds. Some slight changes in construction have seemed to overcome this difficulty, as we hear very little from it, except on some of our earlier looms. It is perfectly easy to remove this magnetization by passing the heddles through an *electric coil*, and we have demagnetized several lots for our customers.

Sometimes the lower ends of the heddles are seriously bent or twisted by the action of the feeler-bars. This, however, is due to improper adjustment whereby the loom continues to run when a heddle is down, the heddle thus receiving hundreds or even thousands of blows before the broken thread is discovered and pieced up.

Like every other mechanism that contacts with a cotton thread, the heddle is smoothed by use in a way which no previous mechanical method can attempt to duplicate. Our steel

heddles will therefore work much better after a few weeks' use, and cause much less warp breakage than when on their first warp. We polish the eyes in the best manner known—in fact, we use especially invented processes; but the rubbing contact of the cotton thread gives the final finish to the surface. It is impossible for this wear to ever make a sharp edge, as the thread turns its corner in such a way as to continually round the edge.

So far as our experience goes we see no reason why steel heddles **should not last indefinitely**. We have had sets running for ten years that are better than when made. Of course they may get bent or damaged by carelessness, but there is nothing in the normal operation to injure them.

In our great variety of experiments with various designs of steel harnesses, we have arrived at the conclusion that in order to secure the best results the heddles must be left with freedom to adjust themselves to conditions. With certain weaves, however, it has been noticed that the heddles will sway or bend to excess, and where this becomes serious we have found it advisable to use *separators*, which keep the heddles from swaying.

COTTON HARNESS STOP-MOTION, ROPER TYPE.

With this attachment, the ordinary *twine* or *cotton harness* is used, the stop-motion being applied *between* the harnesses and the lease rods, *two* or more threads being drawn through *each drop wire*. The threads in this stop-motion pass through *long slots* in the wires instead of *round eyes*, there being *two* such slots,—one for the passage of the threads, and the other for the passage of the *drop wire bar*. We sometimes use a separate *free bar* or *weight* passed through the *lower slot* and resting on the *drop-wires*

to keep them *vertical* in action. The *stop-motion girt, knock-off*, etc., are similar to those already described. We also use a *back rod* or *warp support*, as with the steel harness. The *stop-motion girt* can be raised or lowered and should be set in position for the *feeler bar* to *clear* the drop wires when the shade is wide open and no warp threads broken. It should also be set high enough so that when the shade is wide open it will not pull the drop wires up to their full limit on the drop wire bar. This can also be adjusted backward or forward so as to give room for additional harnesses. The *feeler bar*, which is the piece of sheet steel bent at right angles, with teeth in the edge, should be set so that when it has reached the end of its forward movement, it will be *under the girt* and close to it. While this form of stop-motion will apply for many forms of three, four and five harness weaves, there are special classes of shedding to which it will not apply. We have therefore introduced the *third* form, the *single thread* stop-motion, which can be used with any style of weaving, including *dobbies* and *jacquards*.

SINGLE THREAD STOP-MOTION.

With this construction, there is *one detector* or drop-wire for *each thread*. We apply it in several ways, our more common method being to arrange the drop-wires in *two banks*, using them to also do the *leasing* in place of the ordinary lease rods. We can use *three banks* if necessary. When using two banks, there are *front* and *back box plates* instead of a center girt. The *feeler bar* is different; it being *flat* instead of bent at right-angles, and it oscillates between the two banks. To prevent the drop-wires from slipping or twisting when engaged by the *feeler-bar*, we place *serrated bars* on the bottoms of the box plates. The top

edges of the box plates serve as *warp supports*. The feeler bar having double action requires *two knock-offs* and *two oscillator rods* between the *cam* and the *feeler-shaft*.

In setting this stop-motion, throw off belt or remove key as before, placing the shipper handle in its notch in the shipper lock. Set the *knock-off link*, (the long casting forming connection to the shipper handle,) against its *bearing* on the *cam hub* so as to have no back lash. Then place the feeler bar in the center between the box plates and adjust the *two small castings* on the feeler shaft which we call the *tight* and *loose oscillator fingers*. These should project, or hang evenly, on each side of the shaft. Now loosen the *set screw* which holds the *stop-motion cam* on the *cam shaft* so as to be able to revolve the stop-motion cam by hand and set the *tight knock-off*, the small casting fastened to the stud in the *knock-off link* by a set screw, so that it will clear the point of the cam hub 1-16 to 1-8 of an inch. Turn the cam by hand until the cam follower rests on the lowest point of the cam and the feeler bar is near the back plate. Then connect the *loose oscillator finger*, that is on the feeler shaft, with the cam follower by means of its oscillator rod, and adjust the rod so that as the cam revolves the feeler bar will be moved from side to side equally. When this has been done, connect the *tight oscillator finger* that is on the feeler shaft with the loose knock-off by means of its oscillator rod and *adjust the rod* so that the knock-off will clear the projection on the cam hub as the cam revolves. If, when these connections and adjustments are made, the feeler bar should not move an equal distance each side of the shaft, the trouble may be overcome by further adjusting the oscillator rods. The *spring* on the *stud* which carries the *knock-off* and *cam follower* should be set just tight enough so that the cam follower will follow the cam properly. The *tension* of the spring on the loose oscillator finger on the feeler shaft should be so *regulated* that it will hold the two fingers together on the shaft.

RELEASE MOTION.

With all of our warp stop-motions except the steel harness, trouble was formerly experienced on account of the feeler bar grasping and holding the drop-wire after the loom has been stopped by a broken end. In such a case the end was drawn in without raising the drop-wire, so that the loom was stopped a second time, or else the weaver was compelled to find the drop-wire and release it from the grasp of the feeler bar by hand.

We now apply with our cotton harness warp stop-motions, devices which either automatically *release* the drop-wire upon stoppage of the loom, or enable the weaver to quickly find the drop-wire which is down and then enable him to easily release it by hand. These involve almost no additional parts and save considerable time for the weaver.

SLACK THREADS.

Slack threads often cause trouble by letting warp detectors of any pattern drop low enough to engage the vibrator and stop the loom, causing annoyance to the weaver, who may hunt a long time for the supposedly broken thread. Sometimes the trouble is due to the whole warp being woven too slack by improper tension of the let-off, but the greater difficulty is from individual threads. We have tried to arrange sufficient leeway to overcome this trouble, but if it is found serious, the mill should give more attention to its *warping* and *slashing*. Sometimes the relative position of the girt with relation to the whip-roll is the source of the trouble. On some fancy weaves where many har-

nesses are employed, several of the threads will remain necessarily slack all the time. If there are but a few of these threads it is easy to obviate the trouble by letting them *run without detectors*, as they are not liable to break in any event on account of their slackness. If there is a great number of loose threads in the pattern, it may be advisable to run them on a *separate warp beam*.

WARP BREAKAGE.

Ever since our first experiments with Northrop Looms, we have continuously run them in our own shops with careful supervision and inspection of product, and we feel that we have had more actual tests made of various weaving conditions than have been collected by all other experimenters on looms in all time. Some of the results are curious, showing how impossible it is to draw definite conclusions from machinery that employs so variable a material as cotton fibre. We keep an actual record of warp breakage and find that it varies in different years from as high as 24 warp breaks per loom per cut in one year down to an average of 12 in another, with no perceptible change in conditions other than the quality of the cotton used in making the yarn. All know that the fibre of different crops is not similar. Under the ordinary conditions we expect that the breakage on print warp with either steel or cotton harness should average between 10 and 15 breaks per cut. If warp breakage were to be reduced without attention being paid to other factors, looms would be quite differently designed. In order to produce *cover* on the cloth the yarn is *strained harder* in the *lower shade* and shedding cams are given a *jerky motion* in order to keep the shades open for the shuttle to pass properly. Our steel harness

will break more ends for the first few weeks while the yarn is giving a final polish to the eyes.

KNOTS.

It was figured some years ago that two-thirds of the warp breakage on a loom came from the *knots* made in piecing the yarn together, as these knots would fray adjoining threads or be caught *in the reed* or *between the heddles*. The number of knots is reduced by spooling from *large warp bobbins*, and by making good yarn which will have *few piecings* to cause breakage at the spooler or warper. A certain number of knots is unavoidable, but the way the knot is *tied* affects the situation materially. In the old hand method the operative at the spooler tied a knot with long ends, so that for some time we advised the tying of a *weaver's knot* at the spooler which would not only have short ends, but be less objectionable in size. We believe that in Europe spooler tenders are forced to tie a weaver's knot, and some mills which adopted the practice here found no trouble after getting the help trained, the girls spooling as great a product as before. Since the introduction of the *automatic knot tyer*, however, spooler knots as tied by machinery become much less objectionable as the machine leaves short ends and apparently ties the knot hard and compact. The automatic knot-tyer has gone into such extensive use that our recommendation is practically superfluous. Careless help can tie bad knots even with the knotter and should be followed up if long ends are noticed in the warps.

HARNESS CAMS.

It is absolutely necessary for good shedding to have the *treadle rolls* in continuous contact with the cams. If there is too much angle on the *cam point* there naturally will be more tendency to throw. Harness cams should be set to start opening the shades with the lay at the *bottom center* of the crank. If *tight selvages* are desired the cams may be delayed a little, or conversely, for *loose selvages*, the lay may be pushed back a little. This applies to looms running in the usual American manner, known as the *under-throw*. With *over-throw* looms, of course, the setting would be directly opposite. We built several orders of overthrow looms for certain of our customers at one time, but found that they had no appreciable advantages which could not be secured as well by simple changes in design on the under-throw principle. As to *shape* of harness cams we decided after extensive tests to use a 60° rest cam with all widths of loom up to and including 40 inch. If read with relation to the upper shaft, these cams would be known as 120° rest cams. On wider looms the rest is made longer until on 108-inch looms we put on 180° rest cams. There is no definite fixed rule about the shape of the cam. Different weavers have different ideas as to the amount of rest and the amount of shade opening. We try to satisfy our customers according to the goods woven and the width of loom weaving them. In many cases the proper cam can only be determined after experiment.

SELVAGE.

Selvage threads are usually looser than the others, often causing the edge of the cloth to crinkle or be longer than the center. This is due to carelessness in setting the *temples*. If the temple is too far back, the yarn will *draw around* it and stretch the thread, as the width of the cloth in the reed is greater than in the woven piece. If the temple roll is not free or runs hard for any cause, it will stretch the threads in the same way. Also if the yarn is not put on the yarn beam properly; that is, if it is *filled higher at the ends* than in the center, the selvage will be slack. Where *double threads* are used for the selvage and pass through one harness eye, they cannot control the warp stop-motion unless both of them should break at once. Many mills use *twisted selvage threads*, which, of course, overcome this trouble. As there is more strain on the selvage threads the twisted threads would seem to have an advantage also in *lessening warp breakage*.

CARE OF TEMPLES AND TEMPLE THREAD CUTTERS.

To insure proper care of temples, system is necessary and we strongly recommend the practice of all up-to-date mills who have the loom fixers *take out the temple rolls* and thoroughly clean them and slightly *oil the pins* that hold the roll in place every time a warp is run out before a new one is allowed to be started. The fixer should also examine the *temple thread cutter* at the same time. With this amount of care the usual troubles will be

entirely eliminated. The temple thread cutter is only supposed to cut the thread leading from the hopper stud to the cloth *when the filling is changed*. A loose thread at the selvage left by the filling running out will not necessarily be cut by the thread cutter, so that the presence of such threads does not indicate that the thread cutter is not working. These loose threads are common on all looms. In setting temples, place the lay fully forward and set the *temple head* about 1-16 of an inch from the *reed*. The *thread cutter knife* can be removed by detaching the *spring* on the *cutter arm* and pulling the cutter out, at the same time raising the front of it as high as possible. It can be replaced without difficulty. A *strip of leather* is placed on the lay opposite the temple heel and cutter arm to strike them when the lay comes forward. The strip at the thread cutter side is made long enough to strike both the *temple heel* and the *cutter arm*.

The knife and the steel in the bar should both be sharp, and care should be taken that the former does not get bent so that it will not cut the thread.

The temple should be set as close to the fell of the cloth as can be done without cutting the running filling. This is important as the right-hand fork is "out of commission" from the time that the bobbin is transferred to the time that the temple thread-cutter cuts the thread close to the cloth, and in case of a filling break during this period this fork will not detect the absence of filling as it should. Of course, the left-hand fork should stop the loom on the next pick but it sometimes happens that when the shuttle crosses the loom the thread will catch in the shade, and the loom will go on running although a mispick has been made.

Care must be taken of course, to see that all the parts of the temple are correctly fastened together. If *heel screws* are not tight, the temple may damage the reed. The reciprocation of

the *temple bar* produces wear unless properly lubricated. If the temple heads get loose, the teeth on the rolls are liable to be damaged by pressing against the bar.

FEELER FILLING CHANGER.

The *feeler motion* is placed on the left hand side of the loom when the hopper is on the right hand side. It is set so that the filling feeler will pass through *slots* in the *front box plate* and *shuttle*, coming in contact with the yarn on the bobbin or cop as the lay beats forward. When the filling in the shuttle has been nearly woven off so that it will no longer move the filling-feeler, the *filling-changing mechanism* or *battery* operates, supplying a fresh bobbin or cop to the shuttle when it is thrown to the other side of the loom. In case the filling breaks before it has been woven off sufficiently to operate the feeler, the loom will stop, thus enabling the weaver to find and *match the pick* by hand, as in common loom weaving. The mechanism can be set, however, so that it will supply fresh filling at such times if desired. This allows occasional faults, but on some goods where it would not do to have mispicks every time the filling changed, it would do no harm to have an occasional mispick, and the failure of the loom to stop for filling-breaks means increased production for the loom. To set the feeler, place an *empty* bobbin, or cop skewer with an empty tube in the shuttle and bring the lay to its extreme forward position. Turn the *adjusting screw* in the feeler until the end of the latter is about the thickness of a layer of yarn from the bobbin or cop tube. Then take several bobbins or skewers having a small quantity of yarn on them, place one in the shuttle, and start the loom. If it is thrown out before enough filling is woven off, or if the filling runs out

entirely before the bobbin or skewer is thrown out, the adjusting screw can be turned either way till the feeler is effective. Several trials may be necessary before the feeler is set properly. The *coil spring* around the *shank* of the feeler regulates the pressure on the filling in the shuttle. The tension on this spring is made as light as is consistent with proper action. If too strong, it will push the bobbin out of line. From time to time the weaver should examine the *front* of the filling-feeler, where it enters the shuttle and contacts with the filling. **If rough, it should be smoothed** with a little *emery cloth* or it may wear the filling and break it. While our present feelers are so made as to run independent of back lash, and looseness in the lay crank arms, it is well, of course, to have lost motion taken up. Pains should be taken to see that the shuttle is properly boxed at the feeler end, as well as the hopper end, of the loom, or the feeler may *strike the shuttle* itself instead of passing through the slot in it. It seems almost useless to explain that **the feeler requires special bobbins with cylindrical contour**, but parties have actually tried to run the feeler with coned bobbins at times. With our earlier filling-feelers any change in position of the *front box plate* necessitated readjustment of the feeler itself. This is not necessary with our present feelers.

Be careful that the filling-feeler passes through the slots in the box-plate and shuttle without touching. It is well, however, to **set it as near the upper edge of the slot in the shuttle as possible**, for the shuttle in running is liable to rise off the lay, and if the feeler is set for the middle of the slot it may then strike the lower edge and be prevented from changing the bobbin. As the possibility for mispicks comes only when the filling has parted or been exhausted, it is desirable to keep feeler-failures as low as is consistent with a reasonable amount of waste.

The bobbin-box which we furnish with our feeler looms is made much longer than our other bobbin-box, not for the sake of holding more empty bobbins, but, in order that the out-going bobbin should have farther to fall, and thus **be able to draw the filling out of the shuttle-eye, and prevent it from being carried back into the cloth.** This box should be emptied often, and should never be allowed to get more than one-third full. On coarse filling it may be necessary to empty the bobbin-boxes three or four times a day.

BOXING THE SHUTTLE.

This is important on all looms, but especially so on Northrop feeler-ooms, as the correct operation of the feeler, the hopper and the self-threading shuttle are all largely dependent on the boxing of the shuttle.

If the shuttle is going too hard into the right-hand box the filling may be *sloughed off* the bobbin, or it may loop around the eye of the shuttle, or it may be thrown out of this eye.

If the shuttle is allowed to go too far into the box the bobbin will strike too far back on the shuttle-spring-cover. Mistreads are often due to this cause, and sometimes this will result in the bobbin being broken or being left in the shade, causing a break-out.

If the shuttle rebounds, the trouble mentioned is likely to occur, and also the more serious trouble of striking the shuttle-feeler, with the liability of cutting the thread although the bobbin is not changed.

There is another point in the running of the shuttle which may escape the attention of the fixer, and if so, mispicks are sure to result. The shuttle may be boxing very nicely on the

right-hand side, and the thread-cutter may be going forward properly, yet the bobbin will not be transferred the first time the feeler operates, sometimes the yarn being entirely run off the bobbin although the feeler operates each time the shuttle is on that side of the loom. This is due to the fact that **there is not quite enough power on the pick toward the hopper**, the shuttle entering the box so late that, as the lay swings forward, the tip of the moving shuttle touches the end of the shuttle-feeler just enough to depress the latch, and prevent the bobbin transfer. As the shuttle continues to move, the shuttle-feeler will, an instant later, pass by the end of the shuttle, and the thread will be cut unless prevented by the bunter.

SPECIAL YARN WINDING ON FEELER BOBBINS.

Bobbins used on our feeler looms are preferably spun with a preliminary *bunch*, in order to reduce the waste left after feeler operation, by mechanism especially attached to the spinning frame. We had several types of mechanism of this character, some automatic and some semi-automatic. Recently, we have developed a slightly different method of obtaining the same end, by which we start the winding of the yarn on the bobbin with a short traverse, gradually increasing the same until the regular traverse is reached. This device is absolutely automatic, very simple in construction, and the results are preferable, since with the bunch it often happened that yarn wound lower than the bunch would break in winding off, by contact with the bunch. We supply the necessary mechanisms to the various makes of spinning frame, at a uniform and moderate price.

In order that the waste on feeler looms may be satisfactorily low without incurring the danger of mispicks in the cloth from frequent feeler-failures, it is **absolutely necessary** that care be taken with these bunch-builders on the spinning frames. If the bunches are too small it will not be possible to always weave down to the bunch without danger of an excessive number of *feeler-failures*. No fixed rules can be given in this matter, but a little attention and experimenting on the part of each mill will enable it to settle the question for itself. Where our latest bunch-builders have been introduced no trouble should be experienced on this score, as a large bunch is automatically produced, and without the possibility of trouble in weaving off.

FEELER THREAD-CUTTER.

The *thread-cutter* used as an auxiliary on our feeler looms is attached to the casting called the *shuttle-feeler*, which is moved up to the lay whenever a change of filling is called for. If the shuttle is boxed properly so that the feeler does not contact with its tip, the thread-cutter will cut the filling which extends from the cloth to the bobbin, the filling not being entirely woven off. A *clamping device* holds the end extending from the cloth to the cutter so that the *temple thread-cutter* will cut it close to the cloth. The thread is thus cut in two places; first, as close to the shuttle as possible, so that the bobbin when expelled can easily drag it out; and next, it is cut close to the selvage. In setting the cutter, take pains to see that the jaws will engage the thread properly. *Heavy filling* may require a slightly different setting than *light filling*. To raise or lower the device, change the position of the *stand* on the loom side to which the whole device is fastened.

The thread should never be cut unless a bob-

bin is transferred. Failure to fulfil this condition is responsible for more mispicks than any other cause. The *bunter* used with the thread-cutter is designed to accomplish this result, and will do so, but it often requires considerable time and skill to get the thread-cutter set in the right relation to this bunter. When the shuttle is out of position so that its tip just strikes the end of the shuttle-feeler (which carries the thread-cutter) the latter will be pushed back and the latch will be depressed below the edge of the bunter. When, however, the shuttle-feeler gets back a certain distance it begins to move to the left, and this allows it to slip by the end of the shuttle. If, now, the *heel* of the *movable knife* on the thread-cutter strikes the bunter on the lay the thread will be cut although no bobbin is being transferred, but the latch should now strike on the slanting portion, below the edge, of the bunter and thus prevent the knife from being closed.

Whenever a bobbin is transferred the outgoing thread should be cut, drawn back and held until cut again close to the cloth by the temple thread-cutter. This requires that the thread shall always get into the opening at the end of the shuttle-feeler, that the knives (both movable and fixed) shall be sharp, and that the movable knife shall work just hard enough so that the thread will be pinched and held, after being cut, at the same time not being so tight that the thread will be cut by the back side of the knife. If thus cut by the back of the knife the thread will not be held and will be either woven into the cloth or left as a fringe on the selvage. This would also happen if the knife were too loose to hold the thread at all, or so loose as to jar open, after drawing the thread back, before it could be cut by the temple thread-cutter.

The thread-cutter should be kept well oiled or it will not go forward properly when a bobbin is to be transferred. When this happens the insertion of a new bobbin may be so delayed

that the yarn will be entirely run off the bobbin and the loom will stop.

LET-OFF.

Let-off motions may be divided into two general classes, *tension* and *friction*. Tension devices are intended to let off a definite amount of warp at each stroke of the lay. It is evident that as the warp beam runs out, it is necessary to turn it faster in proportion to the reduction in diameter, as there must be more movement when nearing the empty beam in order to feed off an equal amount of yarn. With the *Bartlett let-off*, it is necessary to regulate the tension by adjustment of the *collar* on the *trombone* as the beam weaves off, so that enough teeth of the *ratchet* will be taken up each time. Approximately, the warp beam should turn about *three times* as fast when empty as when full, and when full should move at least *one tooth* of the ratchet at each motion of the lay. Improper delivery of yarn will cause uneven strain in the cloth, making it vary in width, and increasing warp breakage. Sufficient *friction* should be put on the *let-off wheel* to prevent it from running by the point where the pawl leaves it. The let-off motions that we now use are the *Bartlett*, *Friction with rope chain or leatheroids*, and our latest mechanism called the *Draper-Roper self-adjusting let-off*. The Bartlett and Friction are standard devices needing no special description here. The self-adjusting let-off is what its name implies; that is, when the tension is once set, there is no need of again adjusting it for the goods being woven. If the goods are changed the tension can be changed to accommodate the new conditions. This let-off will keep the cloth at more uniform width than any other, because the tension is more uniform. No special reference to

detail is necessary as the adjustments are similar to those for the Bartlett.

WARP BEAMS.

There is, of course, an advantage in putting as much yarn as possible on the beam, and our new let-off will allow large beams with little trouble, as the tension can be regulated to the greater difference in diameters. The larger the beam head, however, the greater the trouble with *crossed threads*. We soon changed from 16 to 18-inch beams, and now furnish 20-inch beams when desired. We do not, however, recommend larger than 18-inch beams for fine numbers.

TAKE-UP.

We have a number of take-up motions which we apply to our looms, the particular motion used depending on the model of the loom and the goods to be woven. Most of our take-ups are of the *high-roll* type, although we can supply *low-roll* take-ups with some of our models if desired. As the general operation of the different take-ups is very similar, we will here describe in detail only the one in most common use—the high-roll, *spur-gear* take-up with *over-pick* take-up pawl. The same take-up with an *under-pick* take-up pawl is also largely used, the only difference being that this pawl acts on the under side of the pick-wheel, its active stroke thus coming with the forward instead of the backward beat of the lay.

With this take-up the take-up roll is placed next to and

inside of the breast beam. This take-up roll has a *gear* at one end which meshes with an *intermediate gear*, and this in turn meshes with the *change gear*, the latter being driven by the *pick-wheel*, which is located about half way between the *front girt* and *breast beam*. The pick-wheel is operated by the *take-up pawl* which is attached to the *lay sword*, and as the lay swings back, takes up one tooth at every pick. The pick-wheel is prevented from letting back by the *hold-back pawl*, which is fastened to the *cloth roll stand*. Inside of the hold-back pawl and on the same stud is the *slack pawl*. When the filling breaks the hold-back pawl is lifted, allowing the slack pawl to let back the ratchet wheel from one to three teeth, as the quality of the cloth may require, thus avoiding *cracks* or *thin places*. The *change gear* is composed of two gears in one casting, one of which meshes into an intermediate gear and the other into the gear on the hub of the pick wheel. This gear is held in place on a *swinging* or *half-circle stand*. Each tooth on one end of the change gear usually represents two picks; for instance, for 64 picks use a 32-tooth change gear, and a 50 gear for 100 picks. We sometimes use a pick-wheel, however, with which one tooth on the change-gear represents one pick in the cloth. After leaving the take-up roll, the cloth is wound on a smooth iron roll called the *cloth roll* which is held against the take-up roll by the *cloth roll racks*. The cloth roll as we now make it has *teeth cut in one end* to be turned by *gear teeth* on the *take-up roll heads*, so that the cloth roll will get a *positive rotation* while starting to wind the cloth. As soon as a little cloth is wound, these teeth will not mesh and the rest of the cloth will be wound by friction alone. The *cloth roll racks* have teeth meshing into gears at each end of the *spring shaft*. The *spring* is wound by a *gear and worm wheel* and *handle* attached to the *front girt*. When not in use, the handle can be put into the *notch* provided for it and be out of the way of the operative. Cloth can be removed from the roll at any time, the

weaver taking off cuts when convenient. As the take-up roll is made of *metal*, it will not change on account of the weather like a wooden one. The *fillet* is fastened to *wooden plugs* inserted into holes in the metal roll. The take-up roll is *adjustable vertically* and can be raised or lowered to adjust the level of the cloth on the lay and give cover. We now usually make this take-up so that the cloth can be run over *several stationary rolls* before having any contact with the take-up roll, so as to give more stretch to the cloth between the take-up roll and the lay, which is desirable on certain classes of goods, but the cloth can be run direct to the roll if desired. The pressure due to the spring on the spring shaft may be varied by turning the *collar* to which it is fastened. When the take-up roll is empty and the cloth roll is forced up against it, the *worm* on the spring shaft should be in such a position that the handle by which it is turned will just go into its notch. The slack pawl has *three small holes* through it in one of which we place a *cotter pin*. Each of these holes represents one tooth on the pick wheel; that is, if the cotter pin is in the first hole, when the loom stops, the take-up will let back one tooth. If in the second hole, two teeth, and in the third hole, three teeth. The cotter pin is placed according to the demands of the cloth. When setting the let-back, turn the loom until the *filling cam follower* or *weft hammer* is in its position nearest the *breast beam*. Pull the filling fork up over the hook on this cam follower and the change mechanism will now be in operative position. There is a *pawl-raising finger* fastened to the *starting rod* by a *set screw* which should be turned until it extends under the end of the take-up pawl and lifts it out of its engagement with the *pick wheel*. The take-up pawl passes under a lateral *lug* on the hold-back pawl, and as the former is lifted, it in turn lifts the hold-back pawl out of engagement with the pick wheel, which is then free to turn backward as far as permitted by the slack pawl. This accomplishes the letting back of the take-up

at the time transfer takes place, and the take-up should be looked after from time to time with great care, to see that the pawl is actually thrown out of engagement every time there is a transfer, thus allowing the pick wheel to turn back as described. If this is neglected **thin places in the cloth will certainly be caused.**

FILLING FORK.

A *filling fork* can act improperly by rebounding so as to avoid catching on the *hook* of the *cam follower*. Our own fork is designed to balance properly; in fact, we think it the best balanced fork in use. A fork can also operate improperly by being raised by a *dragging filling thread*, after the filling in the shuttle is exhausted.

If a fork is very light in action, it may be lifted by *lint* collecting in front of the *grid*. The more common trouble, however, **on our old looms** is due to the lay shifting position, so that the *fork tines* will strike the grid and thus be improperly raised when the filling is absent. Of course, any false operation of the filling fork will cause thin places when the filling runs out, as no change of filling will be called for **so long as the fork continues to lift.**

Our *double fork* gives a double chance against faulty operation; but even with the double fork a shifting lay may operate both improperly. We therefore designed some of our early fork stands to be guided by the lay so that if the loom shifted, the stands would shift also. More recently, however, we have adopted a *lay guide* attached to the loom frame and sliding in another casting bolted to the lay, so that side shifting of the lay is now prevented.

Filling forks are often made with *soft metal tines*, so that the fixer can bend them into any shape desired. **We prefer to make our forks right at the start**, using tempered wire, so that they cannot be easily bent. In our most recent construction, the tines are *cast* into place and their position is absolutely fixed and unchangeable. Our forks are usually made with *three tines*, although we furnish *four-tine forks* for special light goods.

The forks should pass through the grates without touching, and as the tines sometimes get bent and need straightening this should be looked after frequently.

The connections with the shipper-handle must be so adjusted that the loom will be stopped by either fork.

The connections with the take-up should be properly set or thin places in the cloth will be caused.

The same attention should be given to both the right-hand and the left-hand forks on double fork looms as they are of equal importance. It is a great mistake to think that it is only necessary that one fork shall be in proper working order.

LOOM LAY.

A *stiff, heavy lay* is absolutely necessary to weave heavy goods, and the *hand-rail* must, of necessity, be stiff in proportion.

Much trouble is experienced with lays if the wood is not properly seasoned before use. We find it advisable to rough out our lays and let them season some time before finishing. We carry a large stock of lay timber on hand ahead of orders, so that we shall not be forced to use unseasoned stock by any uncommon demand.

The position of the *pivot* from which the lay swings with relation to the position of the *crank shaft* determines the *eccentricity* of the lay's motion, which is advisable in order to give the shuttle more time in crossing, and also to help give *cover* to the cloth.

The *raceway* for the shuttle should be absolutely true, and it is advisable to go over looms with a *straight edge* at times to detect any error. The *raceboard* should be slightly lower than the level of the shuttle boxes, in order to allow for the thickness of the threads which rest on the race underneath the shuttle.

When the lay is at the end of its forward stroke it must be in position to allow proper delivery of a fresh bobbin or cop to the shuttle. Any wear of parts that allows the lay to throw forward too much should be taken up, and if it becomes necessary to shorten the crank arm to take up wear, the position of the lay can still be corrected by adjusting the *eccentric pins* in the *lay swords* to which the crank arms are fastened as explained in section relating to hopper adjustment. Of course it is only necessary to adjust the pin at the hopper end of the lay in order to get the shuttle box properly under the hopper, but great pains must be taken to adjust *the pin at the other end of the lay exactly the same amount*, or else the lay will have a curious eccentric motion, one end beating up further than the other, causing the shuttle to wear into the reed or strike the shuttle box sides improperly. If the wooden parts of the crank arms wear so badly that the eccentric pins will not furnish sufficient adjustment, the wooden parts should be *replaced*. If too much play is allowed in the crank arm bearings, there is possibility of cracks or slight thin places in the cloth when the loom stops.

REED.

The *reed* should be either set in an exact plane with the *shuttle box back plates*, or slightly back to allow for variations, as it will plane the shuttle if too far front. It should be set at exact right angles with the shuttle race, the *hand rail or reed-cap* being filed to fit, and forced firmly into place.

The purpose of the reed is simply to beat in the filling threads, and furnish a *back guide* for the shuttle. As the *dents* furnish more or less of an obstruction to any *bunches* or *knots* in the yarn, it is advisable to have them as *thin* as is practicable, in order that they may offer little surface for side contact, and also be free to give slightly when necessary. In order to have a good running reed, the *edges* of the dents should be *straight* and *smooth*. In nearly every case where mills have complained of shuttles wearing excessively on the back, it has been because the dents of the reed were sharp, scraping the backs of the shuttles, like a fine file, and *fluting* them so that they looked something like a miniature washboard.

In the manufacture of reeds, the straightening and polishing of the dents is by far the most expensive and slowest part of reed making, and when not properly done, simply indicates a poor job, and an attempt to make an extra profit. *Sharp reeds* are also very hard on the warp yarn, the blame of bad running warp often being put on the quality of the yarn, when it is really the reeds that make the trouble. To test a sharp reed, draw the finger nail edgewise across it, and if it wears the nail, the reed is sharp and not properly polished. The dents should not bite the nail any, and should, of course, be in line. Manufacturers should insist on having smooth reeds, and inspect them carefully to be sure that they get what they order. There are reed manufac-

turers who supply proper reeds and have pride in their reputation. It is not our business to recommend special dealers, but we are often tempted to when noting what inferior supplies are sometimes attached to our looms.

The reed dents should be as thin as possible, to allow elasticity and can, of course, be made deeper, if the thinning is inexpedient without it. The manner of holding a reed in the lay is not so positive as it might be, since reeds vary so much in contour. We formerly used an *adjustable fliter* by which the reed could be positively clamped, no matter what its size. The idea was good in itself, but we found that fixers were liable to screw the bolts up *too tight* and pull the reed in front of the shuttle box. We have therefore gone back to the old *reed groove* system, but have improved its form so that it seems sufficiently efficient. In order to fit this groove properly, it is necessary for customers to send us *several pieces of different reeds*, so that we may know how much their size varies.

SHUTTLE BOXES.

The back box plates are set at exact right angles with the lay ends by filing the *ribs* or *fitting strips* at the back of the plates. The back box plates must be set in line with each other, the reed being preferably set slightly back of this line, as it will not do to run any chances of having the reed in front of this line. A long *steel straight edge* is necessary in order to try the plates and see that they are in proper position. The front box plates should be set so that the top will lean slightly toward the back box plates, thereby reducing the liability of the shuttle rising in the box. If set at a right angle it will probably work all right, but it must not lean *from* the back box plate. At the same time it must not

lean much *toward* the back box plate or it will wear the top of the shuttle. With *back binder* looms, the front plates are adjustable and should be set so as to line the point of the shuttle *in the centre* of the picker stick slot. With the front box plate in position, adjust the binder properly by loosening the *nut* on the end of the *screw* which passes through the binder bushing, turning the *bushing* which is eccentric, until the binder is adjusted to the proper position. We have had a great deal of experience with different binder materials, at first being ready to follow the request of our customers, until we had definitely settled the matter to our own satisfaction. A binder may be of wood, wood with leather face, wood with steel face, wrought iron, cast iron, or iron with leather attached. We now prefer a *wooden binder faced with leather*, as we find that leather does not wear the shuttle so badly as either wood or iron. Iron binders bring a hard pressure on the shuttle *when the loom bangs-off* with the shuttle part way in the box, the whole force of the momentum of the lay being transferred through the protector rod, binder fingers, and binder to the shuttle, often breaking its sides, as it is pinched in its weakest part. The wooden binder will give sufficiently to relieve the shuttle, and we think the shuttle boxing is better also as there is more spring to the wood and less weight to be moved.

Our shuttle and the *leather facing* on our right-hand, front box-plate are provided with grooves which come opposite the hole, in the side of the shuttle, from which the filling is delivered as it weaves off. These grooves prevent the filling from being pinched between the shuttle and the box-plate when the shuttle-eye is at the outer end of the box, as is the case on the right-hand side of the loom. As the shuttle wears, the groove in it will gradually become shallower and in time may entirely disappear if not attended to. At the same time, the pressure of the shuttle against the leather facing on the right-hand box-plate

will cause the groove in the leather to fill up, so that we sometimes find that **there is no passageway whatever for the thread.** The thread will then be pinched and flattened out each time the shuttle enters this box, and it will frequently be so weakened that on the succeeding pick it will pull apart. This is very apt to cause mispicks as the thread remains in the shuttle-eye and extends in front of the filling-fork, so that the loom is not stopped as it should be. Sometimes the thread will not break but will stick to the leather and make a fringe on the selvage. These troubles are easily prevented by using a round file to deepen the grooves in the shuttle and leather facing.

PROTECTOR.

The *protector mechanism* on the Northrop Loom does not differ in principle from that on other looms, so that detailed explanation is unnecessary. On our recent models we use a novel method of adjusting the *binder finger*, which we think will appeal to fixers. *Protector rods* sometimes become loose through wear. The *caps* which hold them can be tightened by filing. The pressure of the *binder fingers* on the *binders* is regulated by a *protector rod spring* in the usual way. When we build *front binder looms*, we use a novelty of construction which enables us to still employ the ordinary *frog* and *dagger* protection.

BRAKE.

All looms are equipped with *brakes*, but in one class of looms the brake is worked solely from the *protector motion* when the loom bangs off, while on another class the brake also operates every time the *shipper handle* is thrown off. The latter system is known as the "*Filling-Brake system*," for with the common looms the brake is thus applied whenever the loom is stopped by the filling motion or fork. There is no question but that the application of the brake brings serious jar and strain on a loom. We know this positively, for we have many records taken of looms used with and without the filling-brake attachment, showing that looms which do not apply the brake at these frequent intervals, run with much less cost for repair, and much less loom fixing. We thought at one time the brake was also responsible for breaking of *crank shafts*, but further investigation proved that the more frequent reason for crank shaft breakage **came from the strain of a tight belt**, as noticed particularly in mills where looms were driven from small pulleys underneath the floor, with *short belts* necessarily kept very tight.

While, therefore, we have a filling-brake system, and a most efficient one at that, we have recently discontinued its use on looms weaving goods where the picks were so frequent that the stopping of the loom did not make any possibility of a crack or thin place. On light goods we shall continue to apply them, and the parts, of course, are applicable to looms which may be sent out without them. Our loom has less use for a brake than the common loom as it does not stop for filling exhaustion or breakage.

Any brake, to work properly, should be carefully adjusted. When the brake acts by the motion of the frog it should

not bring pressure upon the wheel before the belt is shipped. The braking surface should be set so as to bear upon as much of the surface of the wheel as is possible. This can be done by means of the adjustment at the bottom end of the brake. The *leather* on the brake will necessarily wear more or less, requiring attention in order to obtain the best results.

LOOM ADJUSTMENTS.

Every new loom will jar screwed parts loose in the first few days it is run. All screws and nuts should be gone over carefully, tightening them securely when loose. There are many theories about the proper adjustment of *whip-roll*, *harnesses*, and *take-up roll*. If cover is desired, an extra strain should be brought on the *lower shed* by raising the whip-roll, or take-up roll, or both. Our *high-roll looms* are provided with liberal adjustment for change in vertical position. *Whip-rolls* are also adjustable for the same purpose.

In weaving drills or twills, strain is frequently brought on the *top shade* by preference. When this is necessary, the whip-roll and take-up-roll should be practically as low as the race of the lay.

It is, of course, necessary to adjust the shedding motion and timing of the pick so that the shuttle can pass through the shed without too much friction. These adjustments must vary with the width and weight of the cloth woven, as it is obvious that with a wide loom more time is necessary. Looms are built with the crank shaft set lower than the lay crank arm pivot, in order to give more time for the shuttle. The use of a *short* crank arm accomplishes the same purpose, if the bearing for the crank arm is extended, but this construction necessitates *heavier* *shaft castings*, and is not so desirable for that reason.

The pick should be set so that the shuttle will just begin to move when the lay is *in the centre* of its back stroke on looms as ordinarily constructed.

DRAWING-IN WARP.

Our steel harness requires no extra labor for drawing-in while drop-wire warp-stops add to the cost. Large beams naturally reduce the expense.

The *Keene drawing-in frame* is of great advantage for any of our stop-motions.

There are interesting and ingenious automatic tying-in and drawing-in machines now marketed which eliminate the extra labor of drawing-in through drop-wires from consideration. They are working in many Northrop Loom mills giving excellent satisfaction.

SIZING WARP.

Where *drop-wires* are used with cotton harness, it is necessary to size the warp with additional care, taking pains to put the sizing *into* the yarn instead of on the outside, as is the custom in a great many mills. The test of proper sizing is found in the amount of *lint* noticed, and the average *warp breakage* counted. No. 28 warp yarn should not break more than 10 to 12 threads per day with a cotton harness stop-motion on ordinary goods. Slow speed at the slasher gives a larger percentage of size. With our steel harness, extra sizing is not necessary; in fact, not advisable, as it may actually increase warp breakage. We recommend the following mixtures for our cotton harness drop-wire system:

SIZING FOR SHEETINGS: 100 gallons of water, 70 lbs. potato starch, 4 to 5 lbs. of tallow, 1 gill turpentine, 1 gill of blue vitriol; boil 20 minutes, or longer if necessary.

SIZING FOR PRINTS: 120 gallons of water, 60 lbs. potato starch, 2 lbs. of tallow, 7 lbs. of Victoria zinc; boil from 20 to 30 minutes.

SIZING FOR MEDIUM WEIGHT GOODS: 120 gallons of water, 65 lbs. of potato starch, 7 lbs. of tallow, 5 lbs. of alum; boil 30 minutes.

For steel harness simply add more water to the above mixtures. Experiment will determine the proper amount for the conditions presented.

Our experts have also found excellent results shown in mills using the following:

SIZING FOR FINE YARNS: 175 lbs. potato starch, 300 gallons water, 16 lbs. "Providence" sizing—cook 40 minutes.

SIZING FOR COARSE YARNS: 195 lbs. corn starch, 300 gallons water, 16 lbs. "Providence" sizing—cook 40 minutes.

SIZING FOR GINGHAM WARPS: 90 lbs. potato starch, 100 gallons water, 16 lbs. "Victoria" sizing—cook 30 minutes.

Weight of sizing varies with color—heavy on Browns, Blacks, Reds and Tans; light on Blues and bleached warps.

SIZE FOR MEDIUM YARNS: 250 gallons water, 84 lbs. potato starch, 12 lbs. "gloy," 8 1-2 lbs. "glycerol," 2 lbs. softening, 1 1-2 lbs. tallow.

The softening is prepared by mixing one lb. of softening with 9 lbs. of warm water and cooking it. 2 lbs. of this diluted mixture is put into a batch of size.

We have no doubt there are other compounds equally good, but these have been called to our attention as giving special satisfaction, while the others may not have had equally enthusiastic sponsors—or their sponsors may not have cared to give away information that might benefit competition.

LOOM POWER.

We believe that all authorities are wrong on the question of the amount of horse-power required for the looms built today. The old experts figured from tests made with light pattern looms, run at low speeds. Every builder puts more weight into his loom today, and higher speeds are in vogue. It is possible that our loom requires slightly more power than the common loom for the same goods, as it uses a heavier shuttle, and we believe in a stiff, heavy lay. With our first print-cloth loom we had an admirable opportunity for test, as we ran a room of 80 looms from a single engine, and could indicate the power absolutely. At 190 picks, they showed 3 3-4 looms to the horse-power, not counting the shafting.

CLEANING LOOMS.

It seems needless to emphasize the necessity of keeping any machine properly cleaned and properly oiled. Different mills have different systems in this respect, some insisting that the weaver shall clean and oil his own looms, while others have special cleaners and oilers. A loom should surely be cleaned and oiled every time a new warp is put in, and it should also be kept reasonably clean between such periods. We have seen splendid results **from the use of compressed air**, using hose and nozzle to blow dirt and lint off of the loom and out of the oil holes. Under proper system there is a saving in labor, the looms are not stopped so long for cleaning and they are better cleaned. The high-speeded parts of the mechanism need oiling

more frequently, and it should be remembered that every place where two metal surfaces are in rubbing contact demands oil.

While we have never gone into the question of testing oils for looms, we believe that poor oil can do as much harm in the weave room as in the spinning room, and we recommend following the advice of competent oil experts, even if their recommendation seems to involve slight increase of cost in the oil itself.

REPAIRS.

It is somewhat difficult to get at average figures of expense in this line, for new looms will need more frequent repair until the weavers and fixers get used to them. We can figure fairly well ourselves from the amount of parts sold to our customers, although many orders are for parts to be kept as stock on hand. Sometime ago we figured the average repair cost per loom per month at 12 1-4 cents, not including *shuttles* or *strapping*. We understand the repair cost of the common loom, including shuttles, is about \$3 per loom per year. There are many mills using both common and Northrop looms, which inform us that the repairs on their Northrop looms are *actually less* than on the common.

PRODUCTION.

Many mills take advantage of the capacity of the Northrop loom for running without the attention of the weaver by starting the machinery before the weaver arrives and also running during the noon hour and possibly sometime after the weaver has

left at night. In such mills the production is often over 100 per cent. of that possible during regular hours. The comparison with common looms, which produce less than 90 per cent., is interesting. It is quite common for Northrop looms to give 95 to 97 per cent. of product without the gain by running over time. A mill should not be especially proud of this showing, however, for it simply proves that their weavers are *not spread out over their proper number of looms*. It may take many years to kill the popular fallacy that production of cloth *per loom* is the great end for attainment. *Production per weaver* is rather the end that should be aimed at.

LOOM SPEED.

We have never favored high speed for looms, although the Northrop loom can run at high speed if necessary. Simply as an experiment we have run one of our print looms at 280 picks. We have had looms running for weeks at a speed of 220 picks. There is nothing in the addition of our novel mechanism which limits the speed in any way. Our reason for advising low speed, therefore, is not because our loom is handicapped, nor because we wish to sell more looms, as some uncharitable persons have asserted. Increase of speed increases the breakage of warp, requires more fixing and costs more for repairs. Since the introduction of the Northrop loom many mills in this country have speeded their common looms. Perhaps they wish to wear them out more rapidly and thus be ready earlier for replacement by Northrop looms. We doubt if there is any other good reason for the change. They run looms at high speed in England, but simply because of the domination of the trades-unions, which will not allow weavers to run more than four looms. Under

such circumstances the manufacturer is bound to get all the product he can from each loom without caring especially whether he increases the number of duties necessary.

COSTS.

The common plain loom, as ordinarily built, is largely a foundry product and the cost necessarily varies with the market prices of raw materials. In 1894 we learned that an outside builder estimated that a print loom weighing 900 pounds figured \$27 for stock, \$9 for labor, \$3 for painting and \$11 for general expenses with profit, making a total of \$50. Most builders put more iron in their plain looms today, very possibly patterning after our own increase when we first commenced the building of looms. We invite comparison of our loom as a machine product with any other made, for we not only secure uniformity by machine molding, but we also put more tool work into the loom parts than any other builder we know. Our foundry castings have a world-wide reputation and our tool equipment for the manufacture of looms is entirely modern. While the prices we charge for our product may seem high, the additional expenses of manufacture must be taken into account, as well as the extra mechanism which we supply.

LOOM EQUIPMENT.

The usual common loom, as sold to the trade, includes no extras in the way of parts not secured to the loom, except the *beams*, 1 1-2 being figured to each loom. Our Northrop loom, on the contrary, is furnished with *one shuttle per loom, check*

stands, shuttle guard, filling fork, and one loom seat to every eight looms. We also furnish *steel heddles or warp stop detectors* in quantities as ordered and supply our own *temples* of whatever pattern desired, at regular prices. The following list specifies the extras which are usually purchased from supply dealers, although we can furnish sample lots, if required, at their prices: *Lug straps, lease rods, jack sticks for cotton harness strapping, cotton harness, reeds, lease rod holders.* We can supply *thin place preventers* on order and also sell *extra pick gears, auxiliary shaft with gears* for 3, 4, or 5-shade work, *selvage motions*, etc., at extra cost.

DOUBLE PICK CLOTH.

In view of the many attempts at introduction of weaving novelties that produce cloth with two threads in a shade, we might call attention to the fact that such cloth is easily woven on our Northrop loom by *winding two threads on a bobbin.* With this system double production is assured, but the cloth is not of the regular trade standard. We mention this not to suggest adoption, but merely to prevent waste of time on experiment with *double bobbin shuttles, needle looms*, etc.

CLOTH DEFECTS.

Cloth as woven is usually inspected for imperfections, such as *thick and thin places, cracks, oil stains, scratch-ups, thread runs, wrong draws, too many threads* in a harness eye or reed dent, *overshots, skips, kinks, loops, unevenness, bareness, reediness, lack of weight, or narrow width.* Thick and thin places are usually

caused by imperfect action of the let-off or take-up and on the Northrop loom by the filling fork being out of order. Cracks or slight thin places are caused by the loom stopping and being started, especially if the weaver turns the loom over while mending in warp or placing the shuttle. Our latest take-ups are arranged so that they will not operate *unless the shuttle is picked*. Excessive looseness of parts in the loom may also cause cracks when stopping or starting. Oil stains usually result from carelessness. Care should be taken, for instance, in *oiling the hopper stud* on a Northrop loom not to let any excess of oil drip on the filling bobbins. If bobbins are allowed to drop on the floor they may get dirty and show streaks in the cloth. Scratch-ups and thread runs are practically obsolete where Northrop looms are used, for the warp stop-motion, if kept in order, will prevent either one. Wrong draws and extra threads should be detected by the weaver. Overshots are greatly reduced on our loom, especially with our steel harness motion. Of course, overshots are possible if the harnesses and pick motion are not properly timed. Skips are also caused by improper adjustment of the harness or pick, or if the picker is not in proper position. Kinks result from filling not being properly conditioned and also from weaving goods too narrow for the width of the loom. Also by using a *too heavy fork*, or *not sufficient friction* in the shuttle. Too much power in the pick will also cause them. Loops are almost always caused by the harness not shedding properly, especially on five-harness goods. Uneven cloth is usually made when the let-off or take-up is not working right, although uneven filling will also give the goods a similar appearance. The faults in the surface appearance of the cloth are determined from the standard set by the buyer, and this may vary so that a fault on one class of goods would not be detected on another. Weight and width must be kept right. We believe our *Draper-Roper let-off* will produce more even goods

than any other in the market, and our high-roll take-up principle will also assist in keeping the width uniform. Of course, the weight will vary if the take-up is not absolutely uniform and positive in action. Our iron take-up roll is of assistance in keeping the picks uniform. Another defect not always classed as a defect, is the *mispick*, or lack of thread in a shade or double thread in a shade. With ordinary two harness weaving the presence or absence of threads is hardly apparent except on close examination. When goods are *napped*, it is highly important that mispicks should be avoided. In common loom weaving the weaver is personally responsible for a mispick, as he can find the pick by turning the loom over and taking care to make a proper jointure. Some weavers escape mispicks on common looms by stopping the loom and changing the filling just before the filling weaves off in the shuttle. Our feeler mechanism copies this method by automatically changing the filling just before it is woven off. It has been found that the Northrop loom on three-shade weaving makes less mispicks than the common loom as run in the ordinary manner, for the usual lapse of time between the detection by the fork and the operation at the hopper brings the new thread into the proper shade a good part of the time. The usual weaving expert has more to say about cover on the cloth than other special feature. Cover is a quality appealing to the eye by evenness and to the feel by softness. Evenness can be positively produced by using reeds having a *dent for each thread* and may also be apparently produced by weaving with the upper shed slack so that the unevenness is disguised. A *soft feel* is produced in a similar manner and can also be given by use of soft twisted filling. Cop filling undoubtedly has advantages over bobbin filling in this respect, although it is possible that bobbin filling may some day be spun with slacker twist if desired. Slackness in shed is produced by the

relative positions of the take-up roll and whip roll, or by the angle of the lay when beating up. Heavy drop wires may take some of the slackness out of the top shed, but we have never found this objection important. Bare cloth is also due to the harness cams not being suitable. Sometimes cloth or warp is soiled by dirt falling through belt holes in the floor above. All mills should be thoroughly equipped with belt hole guards to prevent such difficulty. Sometimes oil from the shafting above the loom will drip on to the cloth or warp. Of course, as cloth is woven from yarn made in other departments, its defects may be due to conditions outside the weave room. If the filling yarn is poorly wound, rings of yarn will slip off, making double filling in the cloth. If not properly moistened it will kink. Yarn may be made from dirty roving or with too much twist. Of course, the slashing of the warp affects the weaving and the goods woven. All the departments of a mill should work harmoniously to produce the necessary result, and the management in charge of all departments is directly responsible for such a result.

LOOM TESTS.

Outside critics have sometimes referred to the tests made in our private weaving department as having little or no value for comparative purposes, because we are supposedly using better yarn and more perfect conditions than are attainable in the average weave room. We wish to correct this impression, by explaining that the warp and filling yarn which we use is not especially prepared for us in any way, but is bought in open market from various mills, and we are confident that if the same yarn were made in a mill which we could control, we should insist on better quality and more uniformity. Our weave

room is merely a space partitioned off in our wooden setting-up room, and while we endeavor to secure proper atmospheric conditions, we know that we do not secure as good conditions as we should in a weaving room designed for that purpose alone. We see no reason why our records should not be bettered in the average mill where our looms are run. The one advantage that we do obtain is that of having sufficient extra men so that careful note may be made of every error in operation that does occur.

DRAPER TABLE OF RECOMMENDED HUMIDITY
FOR THE WEAWE ROOM.

DRY BULB.	WET BULB.	DRY BULB.	WET BULB.
60	58	80	75
61	59	81	76
62	60	82	77
63	61	83	77
64	61	84	78
65	62	85	79
66	63	86	80
67	64	87	80
68	65	88	81
69	66	89	82
70	66	90	82
71	67	91	83
72	68	92	84
73	69	93	85
74	70	94	85
75	71	95	86
76	72	96	87
77	73	97	88
78	73	98	88
79	74	99	89
		100	90

SPEED RECOMMENDED FOR DRAPER LOOMS FOR MEDIUM
WEIGHT GOODS.

28"	190 to 195	60"	128 to 132
30"	185 to 190	64"	124 to 128
32"	180 to 185	68"	120 to 124
34"	175 to 180	72"	116 to 120
36"	170 to 175	76"	112 to 116
38"	165 to 170	80"	108 to 112
40"	160 to 165	84"	104 to 108
42"	154 to 158	88"	100 to 104
44"	148 to 152	92"	96 to 100
46"	144 to 148	96"	94 to 96
48"	140 to 144	100"	90 to 94
52"	136 to 140	104"	88 to 90
56"	132 to 136	108"	86 to 88

There is no reason why our loom cannot run at any speed attained by common looms of the same capacity. We never advocate extremes in this direction. In fact, on heavy goods we would consider the above table too high.

RULES AND INFORMATION FOR WEAVERS.

To find the number of yards of cloth to the pound avoirdupois:

Multiply its width in inches by the weight in grains of a piece containing 1 square inch; divide 194.44 by the product and the quotient will be the number of yards to the pound. *Example:* Width of cloth, 30 inches; weight of 1 square inch, 1.5

$$\text{grains. } \frac{194.44}{30 \times 1.5} = 4.32 \text{ yards per pound.}$$

To find the average number of yarn required to produce cloth of any desired weight, width, and pick:

Add together the number of picks per inch of warp and filling; multiply their sum by the yards of cloth per pound, and this product by the width in inches; divide by 840, and the quo-

tient will be the average number of yarn required. For any increase in weight by sizing, proportional allowance must be made in the yarn.

N. B.—As the filling is taken up in crossing the warp, and the amount varies in different goods, this rule is not exact, but will approximate near enough to furnish a basis for practical purposes.

Weight of a square yard of cloth when the weight of a square inch is given:

Wt. of sq. in. in grains.	1	2	3	4	5	6	7
Wt. of sq. yd. in lbs.	.1851	.3703	.5554	.7406	.9257	1.1109	1.2961

To find the size of warp or filling in any piece of goods:

Take 8 or more threads of any known number, say 2 feet long, and tie the ends together; this makes a link, through which draw the same number of threads of the same length of the unknown number, and twist the two links thus made as you would twist a chain. A keen eye will detect any difference in the size of the two links. By adding to or taking from either link, they can be varied in size in proportion to the number of threads used, and brought to nearly equal each other. When as nearly as possible alike, the unknown number can be approximately determined by the proportionate number of strands in each link. Thus, if 28 is the known number and if 7 strands of the unknown make an equal size link of 8 strands of the known, the number of the unknown will be $\frac{7}{8}$ of 28 = 24.5.

Cotton cloth is sold on a basis of a certain number of yards to the pound, with a certain number of picks or threads per inch in warp and filling.

Standard print cloths weigh seven yards to the pound, have 64 picks of warp and filling to the inch, and are called 64×64—seven-yard goods.

Loom reeds are numbered by the number of dents or splits to the inch.

The number of threads in a warp divided by the number of the reed multiplied by the width in inches will give the number of threads in a dent.

Both warp and filling take up in weaving, by passing over and under alternate threads; therefore, one yard of warp or filling will fall a percentage short of making a yard of cloth. This percentage varies with each different size of yarn and number of picks per inch, and for other reasons. It may be safe to say that from seven to eight per cent. is an average shrinkage on cotton goods. On some woolen cloths, the finishing processes reduce the weight so that the calculated weights are as near as may be to the weight of the finished goods.

Yarn is commonly numbered before it is slashed or sized, and in estimating the weight of finished cloth, the quantity of sizing added to the warp must be known.

CONVENIENT MULTIPLIERS.

CIRCLES, AREAS, AND FIGURES.

Diameter of a circle $\times 3.1416$ or $\frac{22}{7} =$ the circumference.

Circumference of a circle $\times 0.31831$ or $\frac{7}{22} =$ the diameter.

Square of diameter $\times 0.7854 =$ the area of the circle.

Square of diameter $\times \frac{11}{14} =$ the area of the circle.

Square root of area $\times 1.12837 =$ the diameter of a circle.

Radius of circle $\times 6.28318 =$ the circumference.

Circumference $= 3.5449 \times$ the square root of the area of circle.

Diameter of a circle $\times 0.8862 =$ the side of an equal square.

Side of a square $\times 1.128 =$ the diameter of an equal circle.

Area of triangle = the base $\times \frac{1}{2}$ the perpendicular height.

Square of the diameter of a sphere $\times 3.1416 =$ the convex surface.

Cube of the diameter of a sphere $\times 0.5236 =$ the solidity.

Diameter of a sphere $\times 0.866 =$ the edge of an equal cube.

Diameter of a sphere $\times 0.6667 =$ the length of an equal cylinder.

Surface of a cylinder = area of both ends $+$ length \times circumference.

Solidity of a cylinder = area of one end \times the length.

Solidity of a cone = area of the base $\times \frac{1}{3}$ the perpendicular height.

Area of an ellipse = long axis \times short axis $\times 0.7854$.

(Approximate only for circles, spheres, ellipses and cylinders.)

CONVERSION OF ONE DENOMINATION TO ANOTHER.

Feet $\times 0.00019 =$ miles.

Yards $\times 0.0006 =$ miles.

Square inches $\times 0.00694 =$ square feet.

Square feet $\times 144 =$ square inches.

Cubic feet $\times 0.037 =$ cubic yards.

Cubic inches $\times 0.000579 =$ cubic feet.

Cubic feet $\times 6.2355 =$ gallons.

Gallons $\times 0.16059 =$ cubic feet.

Gallons $\times 10 =$ lbs. of distilled water.

Cubic feet of water $\times 62.425 =$ lbs. avoirdupois.

Cubic inches of water $\times 0.03612 =$ lbs. avoirdupois.

- Lbs. avoirdupois \times 1.2153 = lbs. troy or apothecary.
 Lbs. troy or apothecary \times 0.8228 = lbs. avoirdupois.
 Lbs. avoirdupois \times 0.00893 = cwts.
 Lbs. avoirdupois \times 0.000447 = tons.
 Tons of water \times 224 = gallons.

STATISTICS OF THE MANUFACTURE OF COTTON
 GOODS FOR THE YEAR ENDING 1905.

(Not including small wares.)

Number of establishments	1,077
Capital	\$605,100,164
Salaried officials and clerks	6,738
Salaries	\$9,911,767
Wage-earners	310,458
Total wages	\$94,377,696
Miscellaneous expenses	\$29,930,801
Cost of material used	\$282,047,648
Value of products	\$442,451,218
Number of spindles	23,155,613
Number of looms	540,910
Cotton consumed in bales	3,743,089
Cotton consumed in pounds	1,873,074,716
Pounds per bale	503
Cost of domestic cotton, 3,629,085 bales	\$209,972,665
Pounds of yarn spun	1,529,483,718

Note that in these Statistics we give the year for which the information applies. The date 1905 as in the tables quoted later means the year ending 1905 or, really, the year 1904.

COTTON PRODUCTS PRODUCED DURING 1904.

	Square yds.	Value	Value per yard
Plain cloths for printing or converting	1,818,216,172	\$80,311,612	.044+
Brown or bleached sheet- ings and shirtings	1,172,309,182	61,253,376	.052+
Ginghams	302,316,132	22,471,867	.074+
Ticks, denims and stripes	256,375,486	23,797,578	.092+
Drills	194,735,303	12,596,063	.064+
Twills and sateens	366,142,513	23,701,305	.064+
Cottonades	25,362,346	2,998,971	.118+
Napped fabrics	330,808,140	26,108,315	.078+
Fancy woven fabrics	306,254,685	28,486,342	.093+
Corduroy, cotton velvet and plush	16,014,556	4,790,573	.299+
Duck	122,601,212	17,005,982	.138+
Bags and bagging	57,067,663	3,953,732	.069+
Mosquito and other netting	36,232,918	994,953	.021+
Upholstery goods, including lace and lace curtains	65,592,212	12,111,698	.184+
	<u>5,070,028,520</u>	<u>320,382,367</u>	<u>0.63+</u>
Yarns for sale		79,885,387	
Sewing cotton		15,043,043	
Twine		1,282,947	
Tape and webbing		49,546	
Batting and wadding		1,173,343	
Waste for sale		10,049,037	
Other products of cotton		2,605,801	
All other products		11,979,747	
Total		<u>\$442,451,218</u>	

Total		\$442,451,218
Cotton small wares, lacings, wicks, tapes, edgings, etc.		<u>8,016,486</u>
Total, including small wares		\$450,467,704
Cost of materials		<u>286,255,303</u>
Value added by manufacture		164,212,401
Wages paid	\$96,205,796	
Miscellaneous expenses	30,487,378	<u>126,693,174</u>
Profit, depreciation, selling expense, etc.		\$37,519,227
Per cent. on product value		8.32 per cent.
Per cent. on value added by manufacture		22.84 per cent.
Per cent. on capital (\$613,110,655)		6.01 per cent.

The average depreciation and selling expense would practically eliminate this apparent profit. The figures given do not admit of proper dissection of this total.

STATISTICS OF MANUFACTURES IN WHICH COTTON YARNS WERE USED IN PART IN 1904.

	Value of Products.
Hosiery and knit goods	\$136,558,139
Wool manufactures	380,934,003
Silk and silk goods	133,288,072
Dyeing and finishing of textiles	50,849,545

OTHER TEXTILES.

	Value of Products.
Flax, hemp and jute products	\$62,939,329
Cotton manufactures	<u>450,467,704</u>
Total for all textiles	\$1,215,036,792

Total for all textiles		\$1,215,036,792
Cost of materials		<u>745,783,168</u>
Value added in manufacture		469,253,624
Wages paid	\$249,357,277	
Miscellaneous expenses	86,110,180	<u>335,467,457</u>
Profits, depreciation, selling expense, etc.		\$133,786,167
Per cent. on product value		11.01 per cent.
Per cent. on value added by manu- facture		28.51 per cent.
Per cent. on capital (\$1,343,324,605)		9.95 per cent.

From Labor Bulletin of the Commonwealth of Mass., No. 48, I derive the following information:

Value of cotton goods increase in 1905 as compared with 1900:			
North Carolina	\$18,881,956 =	66.55	per cent. gain
South Carolina	18,713,723 =	66.32	" "
Massachusetts	18,693,122 =	16.92	" "
Georgia	16,716,603 =	90.57	" "
Alabama	8,607,196 =	105.57	" "

The total value for the country was:

1900	1905	
\$339,200,320	\$450,467,704 =	32.80 per cent. increase.

In 1905 the division of value produced was as follows:

Massachusetts	28.68 per cent.
Rhode Island	6.80
New Hampshire	6.56
Pennsylvania	5.36
Connecticut	4.05
Maine	3.42
New York	2.98
New Jersey	1.90
Vermont	.24
	<u>59.99</u>

South Carolina	10.97	
North Carolina	10.49	
Georgia	7.81	
Alabama	3.72	
All others	7.02	40.01

In 1900 the proportion in the above divisions was as 67.64 to 32.36, showing a decided increase outside the Northern States. The Fall River strike in 1904 naturally affects the figures more or less. (The years 1900 and 1905 as quoted really mean 1899 and 1904.)

IMPORTS OF COTTON MANUFACTURES, 1904.

	Square yds.	Value	Value per yard
Bleached and unbleached	1,309,358	\$155,695	.118+
Printed, painted and colored	46,210,012	7,794,179	.170+
	<u>47,519,370</u>	<u>7,949,874</u>	<u>.168+</u>
Cotton clothing, not including knit goods		2,380,658	
Embroideries, laces, lace curtains, insertions, trimmings, cords and gimps		25,911,684	
Knit goods		6,150,484	
Thread (not on spools) yarns, warps or warp yarns		2,204,154	
All other manufactures		4,323,082	
		<u>48,919,936</u>	
Re-exports of similar goods		332,917	
		<u>\$48,587,019</u>	
Net imports			

EXPORTS OF COTTON MANUFACTURES, 1904.

Bleached and unbleached	566,584,218	\$33,995,134	.160+
Printed, painted and colored	127,916,497	7,325,408	.057+
	<u>694,500,715</u>	<u>41,320,542</u>	<u>.059+</u>
Wearing apparel		3,477,652	
All other manufactures		<u>4,867,886</u>	
		\$49,666,080	
Of the cloth exported the Chinese Empire took a total of		\$27,761,095	

Our Chinese trade is mainly in sheetings and drills, the trade-mark known in China as a "Chop" being of great importance. Our trade-marks are imitated by English and Japanese mills, making competition active. Our goods are preferred on account of their quality and the small percentage of size, but the Japanese are making a great point of the cheapness of their product, and using systematic attempts to take trade away from us. All of the cloth used for outer clothing is dyed by the Chinese after purchase. Cloth is used for clothes, linings, burial cloths, underwear, quilting lining and covering of window space. The Chinese themselves weave large amounts of nankeen, it being understood that in certain parts of China the working population weaves all through the winter on hand looms. Chinese traders are exacting in requirements and insist on goods being absolutely up to sample. If the goods are inferior, the Chinese say that the "chop stinks" and will not use them. It is well known that American goods have been rejected because their cuts were a few inches short in length. The Government Agent suggests that we might increase trade by poster advertising of our trade-marks, explaining the better quality of American goods, etc., since the Chinese are very curious and show great interest in such advertising as has been done by producers of other wares.

NUMBER AND CLASSIFICATION OF COTTON LOOMS BY
GEOGRAPHIC DIVISIONS: 1890 TO 1905.

DIVISION.	Census.	NUMBER OF LOOMS—				
		Total.	On plain cloths—			
			Less than 28 inches wide.	28 to 32 inches wide.	32 to 36 inches wide inclusive.	More than 36 inches wide.
United States ...	1905	540,910	31,901	115,966	94,649	160,231
	1900	450,682	35,601	98,995	79,349	126,082
	1890	324,866	23,648	91,862	55,356	71,591
New England states	1905	324,058	11,228	81,742	40,343	89,978
	1900	298,885	16,765	77,326	37,722	84,916
	1890	250,116	12,609	72,928	35,063	62,508
Middle states	1905	31,748	5,722	1,002	2,568	9,186
	1900	36,134	6,442	3,023	3,501	8,035
	1890	35,074	5,196	10,601	3,628	5,708
Southern states	1905	179,752	14,519	33,167	48,779	59,730
	1900	110,010	12,374	17,930	34,446	32,323
	1890	36,266	5,803	8,309	13,956	2,875
Western states.....	1905	5,352	432	55	2,959	1,337
	1900	5,653	20	716	3,680	808
	1890	3,410	40	24	2,709	500

(Remember that the above dates are for the years ending in 1890, 1900 and 1905.)

“The numerical increase of looms is 90,228. Between 1890 and 1900 the increase was 125,816. The rate has therefore been much larger in the last five years than in the preceding decade. By geographic divisions the increase from 1900 to 1905 was 25,173 in New England and 69,742 in the South. There was a decrease of 4,386 in the Middle states and of 301 in the Western states. The classification of looms shows that the increase is, as usual, largest in the case of those making plain goods of standard width. There is a decrease in the number weaving

narrow goods—those less than 28 inches in width—although there is a small increase in southern looms of that character. The largest increase of all is in the number weaving sheetings more than 36 inches in width. About 9,000 more than in 1900 are employed upon twills and sateens and 16,500 more are making fancy weaves. It is interesting to note the large increase of looms making such goods in southern mills. In 1890 only 1,975 looms were reported in those mills; in 1900 the number had not quite doubled, being 3,856; but at present no less than 10,695 are reported, an increase of nearly 7,000 within the last five years, and the total is about one-sixth of the number for the whole country. The cotton manufacturing of Pennsylvania is chiefly weaving. In the whole country there are 43 spindles to one loom, but in Pennsylvania there are only 19 spindles to a loom. The present report shows a falling off of 1,732 looms in that state, or very nearly 11 per cent."

	Census.	NUMBER OF LOOMS—			
		On twills, including sateens.	On fancy weaves.	On tapes and other narrow goods.	On bags and other special fabrics.
United States.....	1905	68,038	62,214	1,439	6,472
	1900	58,839	45,686	1,709	4,421
	1890	53,726	23,233	(2)	5,450
New England States.....	1905	55,093	41,443	711	3,520
	1900	47,080	31,635	1,586	1,855
	1890	46,346	18,900	1,762
Middle States.....	1905	1,915	10,007	64	1,284
	1900	3,403	10,031	123	1,576
	1890	4,930	2,358	2,653
Southern States.....	1905	11,030	10,695	270	1,562
	1900	8,356	3,856	725
	1890	2,442	1,975	906
Western States.....	1905	69	394	106
	1900	164	265
	1890	8	129

2 Included with bags and other special fabrics in 1890.

The following statement shows the number of active establishments in the several geographic divisions of the country:

DIVISION.	1905	1900	1890 ⁽¹⁾	1880 ⁽¹⁾
United States	1,077	973	905	756
New England states	308	332	402	439
Middle states	204	225	239	139
Southern states	550	400	239	161
Western states	15	16	25	17

¹ Includes cotton small wares.

The foregoing statement is not to be taken as an indication that there has been a decline in the industry in all sections save the South. The large decrease in the number of establishments in New England and the Middle states in 1900 as compared with 1890 was due largely to the elimination from the general cotton schedules at the Twelfth Census, of establishments then and now classified as "cotton small wares." During the last five years there has been a moderate consolidation of establishments, which reduces the apparent number without involving the disappearance or disuse of any important mills. When the statistics of machinery and of products are exhibited, it will appear that the industry has grown in New England by the enlargement of existing establishments. In the South, in addition to the enlargement of the capacity of many mills, there has been a very great actual increase in the number of independent establishments, which have been located in new regions as well as in the neighborhoods where the industry had already been introduced. This fact is shown by a comparison of the number of active establishments in the several states of the South at the enumerations beginning with 1880.

NUMBER OF ESTABLISHMENTS IN SOUTHERN
STATES: 1880 TO 1905.

STATE.	1905	1900	1890 ⁽¹⁾	1880 ⁽¹⁾
Total	550	(2)400	239	(3)161
Virginia	10	7	9	8
North Carolina.....	212	177	91	49
South Carolina.....	127	80	34	14
Georgia.....	103	67	53	40
Alabama.....	46	31	13	16
Mississippi.....	14	6	9	8
Louisiana.....	3	2	2	2
Texas.....	13	4	1	2
Arkansas.....	2	2	2	2
Tennessee.....	16	17	20	16
Kentucky.....	4	6	5	3

1 Includes cotton small wares.

2 Includes West Virginia, 1 establishment.

3 Includes Florida, 1 establishment.

These figures are presented with a caution against drawing from them too broad inferences. Establishments may be large or small. The statistics, even when nothing is shown but an enumeration of mills, do indicate a spread of the industry, and success is commonly followed by enlargement of capacity.—*Bulletin No. 74 of Census Bureau.*

This table of print cloth statistics on the next page is made up for standard cloth 64 threads to the inch, 28 inches wide, and made usually of No. 28 warp and No. 36 filling yarn. As now presented it differs somewhat in data and arrangement from former tables. The waste is now figured as **net** waste and the fifteen per cent. is fifteen per cent. of the cotton **bought**.

PRINT-CLOTH STATISTICS.

Year.	Highest Price of Print Cloth in Cents.	Lowest Price of Print Cloth in Cents.	Average Price. (Not Average of High and Low.)	Price per Lb. in Cents at 7 yds. per Lb.	Average of Middling Uplands per Lb. in Cents.	Probable Cost per Lb. of Cotton Used in Cents, with 15 per cent. Waste.	Margin Between Cotton and Cloth in Cents per Lb.
1890	57 $\frac{1}{4}$	47 $\frac{1}{8}$	5.44	38.08	11.	12.94	25.14
1891	9	4 $\frac{1}{4}$	5.33	37.31	13.01	15.31	22.
1892	14 $\frac{1}{2}$	7	9.81	68.67	31.29	36.81	31.86
1893	19	10 $\frac{1}{4}$	15.20	106.40	67.21	79.67	27.33
1894	38 $\frac{1}{2}$	16 $\frac{1}{4}$	23.42	163.94	101.50	119.41	44.53
1895	27 $\frac{1}{4}$	10	20.24	141.68	83.38	98.69	43.69
1896	19 $\frac{1}{2}$	11 $\frac{1}{4}$	14.13	98.91	43.20	50.82	48.69
1897	12	6 $\frac{1}{8}$	9.12	63.84	31.59	37.16	26.68
1898	9 $\frac{1}{2}$	6 $\frac{1}{2}$	8.18	57.26	24.85	29.24	28.62
1899	9 $\frac{1}{2}$	7 $\frac{1}{8}$	8.50	58.10	29.61	34.13	23.97
1870	8 $\frac{1}{4}$	6 $\frac{1}{2}$	7.14	49.98	23.98	28.21	21.77
1871	8	6 $\frac{1}{2}$	7.41	51.87	16.95	19.94	31.93
1872	9	7 $\frac{3}{8}$	7.88	55.16	22.19	26.11	29.65
1873	7 $\frac{1}{2}$	5 $\frac{3}{4}$	6.69	46.83	20.14	23.69	23.14
1874	6 $\frac{1}{2}$	5 $\frac{1}{4}$	5.57	38.99	17.95	21.11	17.88
1875	6 $\frac{1}{2}$	4 $\frac{3}{4}$	5.33	37.31	15.46	18.19	19.12
1876	4 $\frac{1}{2}$	3 $\frac{1}{8}$	4.10	28.70	12.98	15.27	13.43
1877	5 $\frac{1}{4}$	3 $\frac{1}{8}$	4.38	30.66	11.82	13.90	16.76
1878	4	3 $\frac{1}{8}$	3.44	24.08	11.22	13.20	10.88
1879	4 $\frac{1}{2}$	3 $\frac{1}{8}$	3.65	27.51	10.84	12.75	14.76
1880	5.87	3 $\frac{1}{8}$	4.51	31.57	11.51	13.54	18.03
1881	4 $\frac{1}{4}$	3 $\frac{1}{8}$	3.95	27.65	12.68	14.15	13.50
1882	3.95	3 $\frac{1}{8}$	3.75	26.32	11.56	13.60	12.72
1883	3 $\frac{1}{2}$	3.44	3.60	25.20	11.88	13.68	11.22
1884	3.62	3.08	3.35	23.52	10.88	12.80	10.72
1885	3 $\frac{1}{4}$	2.98	3.12	21.84	10.45	12.29	9.55
1886	3 $\frac{1}{2}$	3 $\frac{1}{8}$	3.51	23.17	9.28	10.91	12.26
1887	3 $\frac{1}{8}$	3 $\frac{1}{8}$	3.33	23.31	10.21	12.01	11.30
1888	4	3 $\frac{1}{2}$	3.81	26.67	10.63	11.80	14.87
1889	4 $\frac{1}{8}$	3 $\frac{1}{2}$	3.81	26.67	10.65	12.52	14.15
1890	3 $\frac{1}{8}$	3	3.54	23.38	11.67	13.02	10.36
1891	3 $\frac{1}{8}$	2 $\frac{1}{2}$	2.95	20.65	8.60	10.11	10.54
1892	4 $\frac{1}{8}$	3 $\frac{1}{8}$	3.39	23.73	7.71	9.67	14.66
1893	4	2 $\frac{1}{2}$	3.30	23.10	8.56	10.67	13.63
1894	3	2 $\frac{1}{2}$	2.75	19.25	6.94	8.16	11.69
1895	3 $\frac{1}{8}$	2 $\frac{1}{8}$	2.86	20.02	7.44	8.75	11.27
1896	3	2 $\frac{1}{8}$	2.60	18.20	7.60	9.33	8.87
1897	2 $\frac{1}{2}$	2 $\frac{1}{8}$	2.48	17.36	7.	8.24	9.12
1898	2 $\frac{1}{8}$	1 $\frac{1}{2}$	2.06	14.42	5.94	6.90	7.43
1899	2 $\frac{1}{8}$	2 $\frac{1}{8}$	2.60	18.83	6.88	8.09	10.74
1900	3 $\frac{1}{4}$	2 $\frac{1}{8}$	3.21	22.47	9.25	10.88	11.59
1901	3 $\frac{1}{2}$	2 $\frac{1}{8}$	3.54	19.88	8.75	10.29	9.59
1902	3 $\frac{1}{8}$	3	3.11	21.77	9.	10.59	11.18
1903	3 $\frac{1}{8}$	3	3.25	22.75	11.18	13.15	9.60
1904	4	3	3.44	24.08	11.75	13.82	10.26
1905	3 $\frac{1}{4}$	2 $\frac{1}{8}$	3.12	21.84	9.80	11.53	10.31
1906							
1907							
1908							
1909							
1910							

"How the introduction of this new loom affects the cost of labor may be shown by a comparison of two accounts of the cost of labor in print cloth, one taken by myself from a mill account of older date, but from one of the best mills in New England, and the other from the workings of recent date, received from a mill but a few days ago.

COST OF LABOR IN ONE POUND OF PRINT CLOTH.

(28 inches, 64x64, seven yards to the pound.)

ITEMS.	1887.	1898.	Differences.
	Cents.	Cents.	1898. Cents.
Carding.....	0.855	0.7	0.155
Spinning.....	1.137	1.1	0.037
Preparing for loom.....	0.697	0.7	-0.003
Weaving.....	2.8	1.6	1.2
Other labor expenses.....	0.239	0.25	-0.011
Total labor cost.....	5.728	4.35	1.378
Difference on account of improved loom.....			1.2
All other differences.....			0.178

The items covering all other manufacturing processes are scarcely worth noticing. The difference is almost entirely traceable to the new loom.

Now, by no possibility can the strain which the North could be subjected to by the South, be so great as the strain the Northern mill has to sustain from Northern mill, and the Southern mill from Southern mill; for the same causes may be found in operation in the South that produce the differences in the North. The differences of this pronounced type are created by the introduction of the so-called "automatic" loom. When, by this change, 50 per cent. in the weaving-cost can be saved, it is obvious that it will not take long to convince mill-owners that it is profitable to discard the loom which was satisfactory until very recently, and to adopt the new loom by which an expert weaver can turn out from two to three times as much cloth in a week."—[*Jacob Schoenhof.*]

One of the cloths made here very largely in the 40-inch looms is 32 inches wide and has 68 ends and 112 picks to the inch of 42's twist and 36's weft. It is woven in 62 yard cuts, and the price paid to the weavers is 27 1-4 cents per cut for the Northrop loom and 56 cents per cut for the ordinary loom. The latter is, I believe, 10 per cent. less than the rate paid in Lancashire, but the ordinary eight loom weaver here can earn \$9 a week and the weaver who runs twenty Northrop looms \$10.50 to \$11.—[*Correspondent of Manchester Guardian.*]

"In a Northern mill, not far away, a Northrop Loom weaver applied for permission to attend a funeral of some departed relative. The overseer naturally disliked to stop product but remembering the capabilities of automatic weaving told him to leave the looms running and hurry back. Twenty-four Northrops were banging away as he washed up and twenty-two were still going when he returned nearly an hour later. We shall approach a situation where the women weavers will bring in their knitting in order to keep busy and the men take physical culture exercises to keep their appetites in order."—[*Cotton Chats*, April, '05.

We sometimes have to meet the assertion that possible profits in Northrop loom weaving are reduced by reason of the higher cost of repair. We emphatically decline to accept any such conclusion. With equal skill in loom fixing there should be no more cost; in fact, records show there is often less cost.

We quote the following from one of our expert's reports on a Northrop loom mill:

"In the year 1904 the mill ran 252 1-2 days of 10 hours each.

"On 800 looms they gave out 261 new shuttles."

Another report on another mill had the following:

"Their cost of supplies for the four weeks ended January 7th, was \$83.25 for 1292 (Northrop) looms; while on the 1174—— looms for the same period, the cost of supplies was \$301.71."

"In an expert's report for December, we note that an overseer running 172 Northrop looms reports his cost of supplies for an entire year as less than \$50. This same mill was getting 98 per cent. production and paying one-half the price for weaving cuts that they paid on common looms in the same mill. The supplies were much less per loom on the Northrop loom than on the common.

"Another mill, visited the same week, reported that the repairs for the Northrop loom cost less than one-half what they cost on the common looms in the same mill.

"In a third mill, they had four weavers running 150 looms, with four battery boys at 40 cents a day each."—[*Cotton Chats*, Feb. '06.

"I found a most illogical argument being used against the Northrop loom, it being suggested that when a Northrop loom weaver left the mill for any purpose, it would stop 24 looms, whereas a common loom weaver absent meant only the stopping of 8 looms. Of course, it is easily shown that in a common loom mill there would be three times as many weavers, who would certainly average the same number of days out per individual as the weavers in a Northrop mill; that is, they would average to have three weavers out in a common loom mill, as against one weaver in the Northrop loom mill, for the same causes."—[*Cotton Chats*, Dec., '06.

"As to weaving cost, there were many mills doing much better than our claim of halving the price per cut. The price paid in Southern mills for regular print cloth, standard length cuts, varies from 6 cents to 8 cents, according to locality. In one mill, the prices were 19 1-2 cents per cut on common loom grades, 9 cents on Northrop, for one line of goods, and 16 1-2 cents on common looms against 7 cents on Northrop, on another style. In another mill the price of weaving for the Northrop looms, counting in section hands and extra help of all kinds, was less than 50 per cent. of the common loom cost on the same goods. Several mills claimed less cost for repairs for Northrop looms as against common looms: in fact, one mill is considering replacing common looms which have only run three years, because they find less cost for both weaving and repairs and less seconds on their Northrop looms."— [*Cotton Chats*, Dec., '06.



"During the scarce-help period many methods were employed to entice workers to suffering sections. Some of the methods were hardly legitimate, altruistic or ethical, but the 'button' advertisement shown in the illustration was clever and convincing. Merrimack weaving **did** run well—it runs well all the time. The two great rooms of Northrop looms are as good an advertisement as their builders could wish for."— [*Cotton Chats*, March, '07.

"The first 100 looms are running very nicely, and they have reduced their weaving price of 30 cents, which they were paying on common looms, to 11 cents."— [*Expert's report of Aug. 17, 1907*.

We all know how clearly imperfections in cloth are shown by running it over a blackboard. We print photographs of cloth with a black paper background which seem to show up very well. These goods are made on Northrop looms with Dobby heads in a Southern cotton mill.

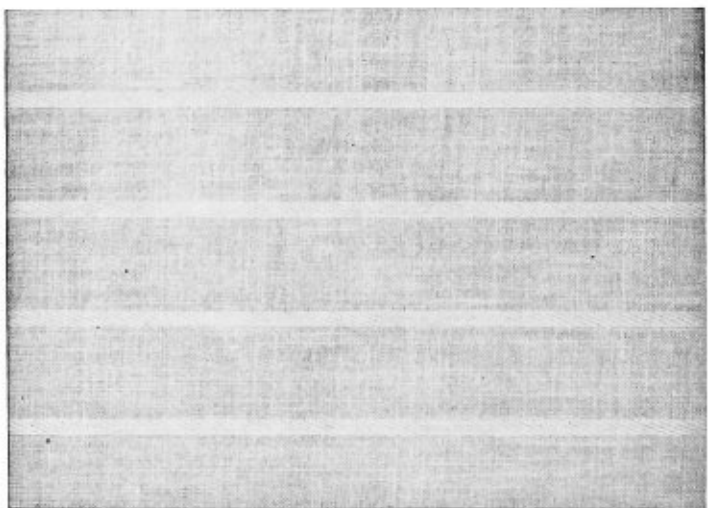
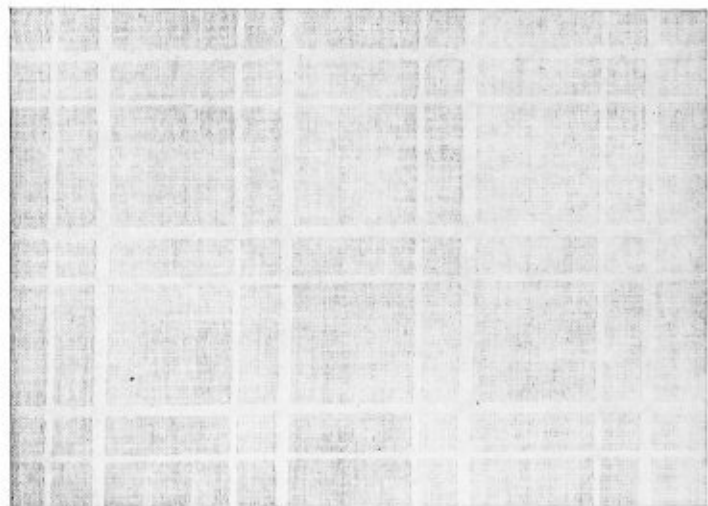

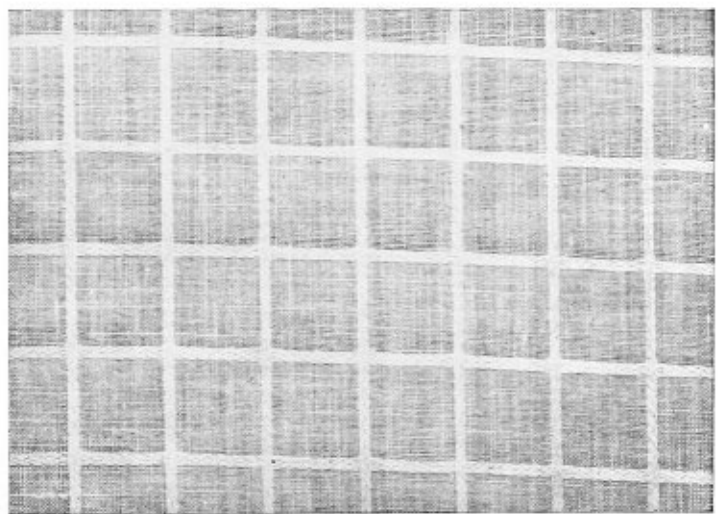
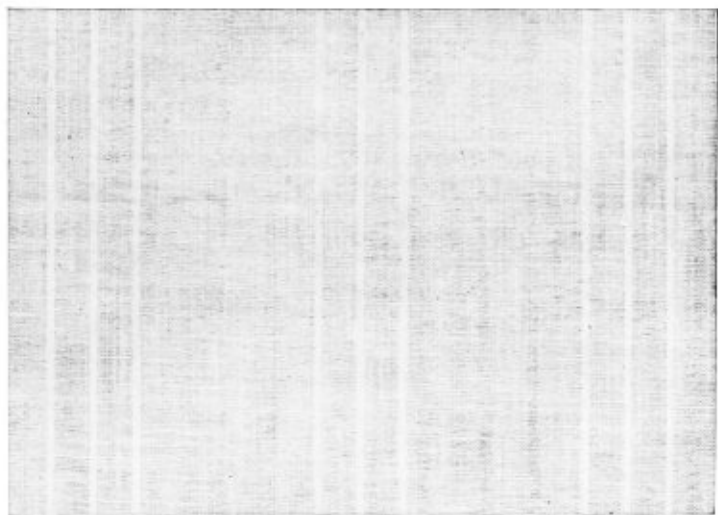

THE LABOR QUESTION.

The introduction of labor-saving machinery is usually attended by decided opposition from the help, since some fear to lose their jobs through the very lessening in labor for which the machine is preferred. The direct and open antagonism to the Northrop loom has been surprisingly small, all things considered. There have been a few small strikes to determine the exact rate of pay; but these differences have been promptly settled, and Northrop loom weavers, as a class, undoubtedly earn higher wages than similar weavers on common looms. The **indirect** antagonism is far more serious in certain sections. Whether existing, or merely feared, it does delay the inevitable change in mills where the help are stronger through their organization than the management in charge. If a general, indefinable attitude of opposition, does succeed in delaying improvement, it not only prevents the mill from profiting, but **it also prevents the weavers from earning the better wages that they might obtain.**

The average common loom weaver might think that an additional number of looms must increase the work to be done, but such is not necessarily the case. A weaver can take more steps in going from loom to loom with eight looms to look after, each requiring a visit every few minutes, than in tending three times as many looms, **if each one only needs a visit at much longer intervals.** The fact that weavers **do** run large numbers of Northrop looms, and **like** to run them rather than go back to fewer common looms is sufficient answer of itself.

All weavers should certainly credit us with the relief from sucking filling, for while hand-threaded shuttles are now used to

some extent on common looms, their use was not so general before we forced the issue by selling a self-threading shuttle. The sucking of filling is damaging to the lungs, especially when the filling is colored. Common loom weavers are short-lived as a rule, their lungs becoming packed with cotton fibre. Weavers have caught consumption and worse diseases by sucking shuttles formerly used by diseased weavers.

When we first brought the Northrop loom to the attention of the trade, it was feared that introduction would throw one-half the then present weavers out of their jobs; but after many years of successful, and comparatively rapid introduction, **there are today more common loom weavers working than there were when the Northrop loom was ready for the market.** The Northrop loom has built up a **new** lot of mills, the looms being run largely by **new** operatives. The old weavers have **not** been displaced; their jobs have **not** been taken away. We hope that they will all be running Northrop looms at some future time; and by that time there should be Northrop looms enough in use to give them all employment. It is somewhat curious to note that labor troubles apparently become more prevalent as conditions really get better. We had cotton factories for fifty years before there was one strike recorded. During that early history the mills were badly lighted and badly ventilated. The ceilings were low, the machinery most inefficient, the work much harder; and yet the help had to work some fourteen hours a day for miserable wages. Today, our cotton mills offer opportunities in short hours and higher wages that should prove most attractive compared with other channels of employment open to the same grade of labor. The modern cotton mill is better adapted for the health and comfort of the operative than the majority of manufacturing establishments. Unlike many employers, the cotton mill invariably pays its help on time. The help know precisely what they are to re-

ceive. The strikes of recent times are almost uniformly based on the single question of wages, the rate usually varying with the relative difference, or margin, between price of cotton and price of goods marketed.

It is a great mistake for the laborers, as a class, to consent to any measures **which tend to diminish that margin**. If working for their own best interests, they would welcome the introduction of labor saving machinery, which enlarges the profit to the mill, and thereby enlarges the possible fund from which higher wages can be paid. It is not exceptions which determine rules, but rather the great average of results. It can be shown conclusively that progress through labor-saving devices **does** increase wages, even though the wage earners themselves are not required to use a higher grade of skill, or a greater expenditure of energy.

It would be folly to attempt a defense of the progress made in the world by the introduction of labor saving machinery. No defense is needed. We will frankly admit that our energies are continually bent on producing machines that will release labor. Experience shows that the labor thus relieved is absorbed by the increase of new mills, this increase being stimulated by the very economies made by the labor saving machinery, as such machinery makes profits and attracts capital to duplicate the results.—[*Cotton Chats*.

WAGES IN EUROPEAN TEXTILE MILLS.

According to a report issued from Manchester by the International Federation of Textile Workers, the weekly wages of English operatives are: Weavers, \$4.86; spinners, \$9.72; card-room workers, males, \$7.29, and females, \$5.35; beamers, \$7.29; bleachers, males, \$8.76, and females, \$4.37; and loom-fixers, \$10.20. In Holland the wages per week are given as follows: Spinners, \$4.86 to \$7.08; card-room workers, \$3.12 to \$4.37, and weavers, \$2.40 to \$4.05. In Denmark the average rates are:

Spinners, \$4.86, and weavers, \$3.89 to \$4.37. Weavers in Flanders running four looms earn from \$2.04 to \$2.88. In Silesia men weavers make \$2.28 and women \$1.68 a week. Referring to upper Franconia, the report states that "the manner of living of the textile workers corresponds to their low wages—plain, scanty, and often insufficient food. Their principal nourishment consists of coffee and bread, herrings and potatoes; meat rarely appears on their table."—[*Daily Trade and Consular Report*, May 29, '07.

The following table shows the fluctuation in weavers' wages at Fall River during the past twenty-three years:

	Per cut
Feb. 4, 1884.....	18.50
Jan. 19, 1885.....	16.50
Mar. 1, 1886.....	18.15
Feb. 13, 1888.....	19.00
July 11, 1892.....	19.60
Dec. 5, 1892.....	21.00
Sept. 11, 1893.....	18.00
Aug. 30, 1894.....	16.00
Apr. 22, 1895.....	18.00
Jan. 1, 1898.....	16.00
Feb. 27, 1899.....	18.00
Dec. 11, 1899.....	19.80
Mar. 17, 1902.....	21.78
Nov. 23, 1903.....	19.80
July 25, 1904.....	17.32
Oct. 30, 1905.....	*18.61
July 2, 1906.....	19.80
Nov. 26, 1906.....	21.78
May 27, 1907.....	23.96

*Average under sliding scale.

The surprising development of American ingenuity, which has placed us far ahead of any other inventive nation, is primarily due to the protection afforded by our American patent system. There are those who consider patents monopolistic and tyrannical, causing much of nuisance to the public at large. They think that without the patent system we should have as many improvements and make greater progress, since all could use the improvements without pay. We know by our own experience that even if inventors were to develop ideas without profit—a most improbable theory—the public would by no means promptly grasp their advantages, but rather decline to consider them at all, in view of the change in habit necessary. People must be forced by persuasion and without the chance for profit there is no incentive to stir the possible persuader. There are valuable ideas in the line of cotton machinery improvements, which are not introduced, since the controlling patents have expired, or because their own patents were imperfect. No one will take the trouble to introduce them since they merely educate a competitor who can copy without the expense of designing and testing. So long as business is done on a business basis, it will be done with a careful reckoning of costs and improvements must be proved of value by those who can be assured of a share in the value. A patent is merely a policeman protecting the rights of ownership; and while some may question the rights of individuals as to possession of property which they did not create, there is no logic that can justly deprive one of a primary right to the creations of his own brain.—[*Address on "Patents and Inventions," Philadelphia, May 15, '07.*]

SALES.

Having controlled the majority of sales for new looms on plain goods for over twelve years, we may now assume that the Northrop loom is certainly well established as an important trade factor. There are mills which still purchase common looms, and there are men who still deny that the automatic loom is suitable for their purposes, and their conditions. When these objections are analyzed, however, we find them not condemnatory of the loom itself, but rather of the situations under which the objectors find themselves. We may deprecate the existence of the conditions, but it is not our business to interfere with them. We can better utilize our time in introducing the loom **where conditions are more suitable.** We are perfectly frank in stating that it is not our aim in business to monopolize the entire trade at any cost, but rather to keep our plant running on fairly remunerative contracts, supplying machinery to those who want it because they know what it will do, or because they have faith in our advice.

On the mere strength of reputation, we could have easily sold thousands of looms in advance of the proof of their accomplishment, but we did not care to risk that reputation. We not only ran a fully equipped weave room for months before allowing a purchase of one loom, but we became large stockholders in new mills that first tested the inventions, perfectly willing to take our share of the loss, if loss should ensue.

The mills that did entrust us with large preliminary orders certainly had no reason to continue patronage, if the looms were unsatisfactory. Notwithstanding the necessarily immature type of device first sent out, the purchasers not only found them satisfactory, but expressed their further confidence by a continuous

entry of repeat orders. If our business were analyzed, it would show that the great majority of our sales is made to those mills which have either tested early lots of looms, or been organized or controlled by men having full experience with the actual running of the looms.

LIST OF NORTHROP LOOMS SOLD IN UNITED STATES TO JULY 1, 1907.

Where looms have changed ownership they are credited to present possessors. Figures in black letters signify increases since our list of 1905. Mills in black letter signify new customers since 1905.

NAME.	PLACE.	QUANTITY.
Abbeville Cotton Mills.....	Abbeville, S. C.....	940
Acushnet Mill Corp.....	New Bedford, Mass.....	417
Adams Mfg. Co.....	North Scituate, R. I.....	24
Aiken Mfg. Co.....	Bath, S. C.....	38
American Linen Company.....	Fall River, Mass.....	100
American Textile Company.....	Cartersville, Ga.....	802
American Spinning Company...	Greenville, S. C.....	758
Amory Mfg. Company.....	Manchester, N. H.....	688
Amoskeag Mfg. Co.....	Manchester, N. H.....	1381
Anderson Cotton Mills.....	Anderson, S. C.....	724
Androscoggin Mills.....	Lewiston, Maine.....	413
Appleton Company.....	Lowell, Mass.....	623
Aragon Cotton Mills.....	Rock Hill, S. C.....	280
Aragon Mills.....	Aragon, Ga.....	170
Arcadia Mills.....	Spartanburg, S. C.....	344
Arlington Mills.....	Lawrence, Mass.....	240
Asheville Cotton Mills.....	Asheville, N. C.....	30

NAME.	PLACE.	QUANTITY.
Ashland Company.....	Ashland, R. I.....	21
Atlantic Cotton Mills.....	Lawrence, Mass.....	423
Atlas Linen Company.....	Meredith, N. H.....	35
Attaugan Mills.....	Killingly, Conn.....	48
Augusta Factory.....	Augusta, Ga.....	105
Aurora Cotton Mills.....	Aurora, Ill.....	96
Avondale Mills	Birmingham, Ala.	512
L. Bachmann & Co.....	Uxbridge, Mass.....	66
Barber-Coleman Co.	Boston, Mass.	1
Barker Cotton Mills Company..	Mobile, Ala.....	325
Barker Mills.....	Auburn, Maine.....	16
Bates Mfg. Company.....	Lewiston, Maine.....	234
Beaumont Mfg. Company.....	Spartanburg, S. C.....	252
Belton Mills.....	Belton, S. C.....	1249
Bennett Spinning Company.....	New Bedford, Mass.....	1
Berkeley Company.....	Berkeley, R. I.....	256
Blackstone Mfg. Company.....	Blackstone, Mass.....	1184
Boott Mills.....	Lowell, Mass.....	1178
Borden Mfg. Co., Richard.....	Fall River, Mass.....	852
Boston Mfg. Co.	Waltham, Mass.	156
Botany Worsted Mills.....	Passaic, N. J.....	14
Boston Duck Co.	Bondsville, Mass.	102
Bourne Mills.....	Fall River, Mass.....	2060
Bradford Durfee Textile School	Fall River, Mass.....	5
Brandon Mills.....	Greenville, S. C.....	992
Bristol Mfg. Corp.....	New Bedford, Mass..	1
Brogon Cotton Mills.....	Anderson, S. C.....	366
Brookside Mills.....	Knoxville, Tenn.....	650
Brookford Mills.....	Brookford, N. C.....	162
Brower & Love Bros.....	Indianapolis, Ind.....	2
Burgess Mills	Pawtucket, R. I.	1294

NAME.	PLACE.	QUANTITY.
Cabarrus Cotton Mills.....	Concord, N. C.....	542
Cabot Mfg. Co.....	Brunswick, Maine.....	204
Calhoun Mills	Calhoun Falls, S. C.	400
Calvine Mfg. Co.	Charlotte, N. C.	300
Cannon Mfg. Co.....	Concord, N. C.....	426
Capital City Mills.....	Columbia, S. C.....	240
Carolina Mills.....	Greenville, S. C.....	356
Chadwick Mfg. Co.....	Charlotte, N. C.....	300
Cherokee Falls Mfg. Co.	Cherokee Falls,	
	S. C.	1
Chewalla Cotton Mills.....	Eufaula, Ala.....	40
Chicopee Mfg. Company.....	Chicopee Falls, Mass.....	126
Chicora Cotton Mills.....	Rock Hill, S. C.....	1
China Mfg. Company.....	Suncook, N. H.....	89
Chiquola Mfg. Company.....	Honea Path, S. C.....	1000
Clemson College.....	Calhoun Station, S. C.	2
Clifton Mfg. Company.....	Clifton, S. C.....	1000
Cochecho Mfg. Co.....	Dover, N. H.....	1129
Columbia Mfg. Co.....	Ramseur, N. C.....	69
Columbian Mfg. Co.....	Greenville, N. H.....	172
Columbus Mfg. Co.....	Columbus, Ga.....	800
Consolidated Duck Co.....	Baltimore, Md.....	190
Continental Mills.....	Lewiston, Maine.....	273
Converse Co., D. E.....	Glendale, S. C.....	550
Cooleemee Cotton Mills.....	Cooleemee, N. C.....	1296
Cordis Mills.....	Millbury, Mass.....	144
Coventry Company.....	Providence, R. I.....	2
Cowpens Mfg. Co.	Cowpens, S. C.	142
Crompton Company.....	Crompton, R. I.....	2
Crown Cotton Mills	Dalton, Ga.	1
Dallas Mfg. Company.....	Huntsville, Ala.....	1211

NAME.	PLACE.	QUANTITY.
Dan River Cotton Mills	Danville, Va.	304
Darlington Mfg. Co.	Darlington, S. C.	592
Drayton Mills	Spartanburg, S.C.	502
Dunbarton Flax Spinning Co.	Greenwich, N. Y.	1
Durham Cotton Mfg. Co.	West Durham, N. C.	300
Dwight Mfg. Co.	Chicopee, Mass.	681
Dwight Mfg. Co.	Alabama City, Ala.	300
Eagle & Phenix Mills.....	Columbus, Ga.	328
Eagle Mills.....	Woonsocket, R. I.	8
Easley Cotton Mills.....	Easley, S. C.	1020
Eastman Cotton Mills.....	Eastman, Ga.	150
Edwards Mfg. Company.....	Augusta, Maine.....	809
Emery, Jere	Putnam, Conn.	25
Erwin Cotton Mills.....	West Durham, N. C.	1901
Eufaula Cotton Mills.....	Eufaula, Ala.	32
Everett Mills.....	Lawrence, Mass.	1228
Excelsior Mills	Farnumsville, Mass.	100
Exeter Mfg. Company.....	Exeter, N. H.	106
Exposition Cotton Mills.....	Atlanta, Ga.	350
Fairfield Cotton Mills.....	Winnsboro, S. C.	190
Falls Company.....	Norwich, Conn.	61
Farnum & Co., John.....	Lancaster, Pa.	12
Farwell Mills.....	Lisbon, Maine.....	132
Firth, William.....	Boston, Mass.	1
Florence Mills.....	Forest City, N. C.	200
Fulton Bag & Cotton Mills.....	Atlanta, Ga.	1591
Gaffney Mfg. Co.	Gaffney, S. C.	1562
Gainesville Cotton Mills.....	Gainesville, Ga.	1076

NAME.	PLACE.	QUANTITY.
Gary & Sons, James S.....	Baltimore, Md.....	88
Georgia School of Technology	Atlanta, Ga.....	6
Gibson Mfg. Company.....	Concord, N. C.....	6
Glenn-Lowry Mfg. Co.....	Whitmire, S. C.....	998
Glen Raven Cotton Mills.....	Burlington, N. C.....	100
Glenwood Cotton Mills.....	Easley, S. C.....	116
Gosnold Mill Corp.....	New Bedford, Mass....	800
Granby Cotton Mills.....	Columbia, S. C.....	1014
Granite Linen Co.....	Wortendyke, N. J.	24
Graniteville Mfg. Co.....	Vaucluse, S. C.....	362
Graniteville Mfg. Co.....	Graniteville, S. C.....	592
Great Falls Mfg. Co.....	Somersworth, N. H....	638
Great Falls Mfg. Co.....	Rockingham, N. C....	172
Grendel Mills.....	Greenwood, S. C.....	748
Grinnell Mfg. Corp.....	New Bedford, Mass....	341
Grosvenor-Dale Company.....	North Grosvenor-Dale, Conn.....	3617
Hamilton Mfg. Co.....	Lowell, Mass.....	372
Hamlet Textile Company.....	Woonsocket, R. I....	56
Harmony Grove Mills.....	Harmony Grove, Ga....	396
Hartsville Cotton Mills.....	Hartsville, S. C.....	680
Hathaway Mfg. Co.....	New Bedford, Mass....	401
Henderson Cotton Mills.....	Henderson, N. C.....	84
Henrietta Mills.....	Henrietta, N. C.....	251
Hill Mfg. Co.....	Lewiston, Maine.....	142
Home Cotton Mills.....	St. Louis, Mo.....	180
Hope Co., Phenix Mill.....	Hope, R. I.....	800
Hoskins Mills.....	Charlotte, N. C.....	580
Indian Head Mills of Alabama	Cordova, Ala.....	416
Jackson Company.....	Nashua, N. H.....	533

NAME.	PLACE.	QUANTITY.
Jackson Mills	Iva, S. C.	640
Jackson Fibre Co.	Jackson, Tenn.	1580
Johnson & Johnson	New Brunswick, N. J.	436
Jonesville Mfg. Co.	Jonesville, S. C.	240
Kansas City Cotton Mills	Kansas City, Mo.	160
Keasbey & Mattison Co.	Ambler, Pa.	6
Kesler Mfg. Co.	Salisbury, N. C.	306
King Mfg. Co., John P.	Augusta, Ga.	1600
King Phillip Mills	Fall River, Mass.	28
B. B. & R. Knight, (Centreville Mill)	Centreville, R. I.	616
Lancaster Mills	Clinton, Mass.	418
Lane-Maginnis Corp.	New Orleans, La.	714
Lanett Cotton Mills	West Point, Ga.	992
Laurens Cotton Mills	Laurens, S. C.	562
Lawrence Duck Company	Lawrence, Mass.	38
Limestone Mills	Gaffney, S. C.	640
Lockhart Mills	Lockhart, S. C.	1604
Lockwood Company	Waterville, Maine	1427
Lonsdale Company	Lonsdale, R. I.	2107
Loray Mills	Gastonia, N. C.	1690
Lorraine Mfg. Co.	Saylesville, R. I.	2
Louise Mills	Charlotte, N. C.	562
Lowell Textile School	Lowell, Mass.	3
Lynchburg Cotton Mills	Lynchburg, Va.	1
Manchester Mills	Manchester, N. H.	681
Manville Co. (Social Mill)	Woonsocket, R. I.	597
Massachusetts Cotton Mills	Lowell, Mass.	556
Massachusetts Mills in Georgia	Lindale, Ga.	2340

NAME.	PLACE.	QUANTITY.
Mass. Institute of Technology	Boston, Mass.	1
May's Landing W. Power Co.	May's Landing, N. J.	3
Mecklenburg Mfg. Co.	Charlotte, N. C.	200
Meridian Cotton Mills	Meridian, Miss.	148
Merrimack Mfg. Company	Lowell, Mass.	530
Merrimack Mfg. Company	Huntsville, Ala.	1718
Methuen Company	Methuen, Mass.	126
Mills Mfg. Company	Greenville, S. C.	560
Millville Mfg. Company	Millville, N. J.	313
Mississippi Agr'l College	Agr'l College, Miss.	2
Mississippi Mills	Wesson, Miss.	49
Mollohon Mfg. Co.	Newberry, S. C.	352
Monaghan Mills	Greenville, S. C.	1262
Monarch Cotton Mills	Union, S. C.	1000
Nantucket Mills	Spray, N. C.	32
Nashua Mfg. Company	Nashua, N. H.	374
Naumkeag Steam Cotton Co.	Salem, Mass.	528
Neuse River Mills	Raleigh, N. C.	150
New Bedford Textile School	New Bedford, Mass.	2
Newmarket Mfg. Co.	Newmarket, N. H.	371
New York Mills	New York Mills, N. Y.	171
Nightingale Mills	Putnam, Conn.	14
Ninety Six Cotton Mills	Ninety Six, S. C.	510
Nockege Mills	Fitchburg, Mass.	13
Nokomis Cotton Mills	Lexington, N. C.	356
No. Andover Silk Mills	No. Andover, Mass	2
N. C. Col. of Agr'l. & Mech. Arts	West Raleigh, N. C.	3
Odell Mfg. Company	Concord, N. C.	40
Olympia Cotton Mills	Columbia, S. C.	2250

NAME.	PLACE.	QUANTITY.
Orangeburg Mfg. Co.....	Orangeburg, S. C.....	392
Orr Cotton Mills.....	Anderson, S. C.....	1504
Ossipee Cotton Mills.....	Elon College, N. C.....	168
Otis Company	Ware, Mass.	2
Pacific Mills.....	Lawrence, Mass.....	2187
Pacolet Mfg. Co.....	Pacolet, S. C.....	1164
Pacolet Mfg. Co.....	Gainesville, Ga.....	1764
Palmer Mills.....	Three Rivers, Mass.....	112
Palmetto Cotton Mills.....	Palmetto, Ga.....	80
Parkhill Mfg. Co.....	Fitchburg, Mass.....	13
Park Woolen Mills	Rossville, Ga.	10
Patterson, S. F.....	Ilchester, Md.....	1
Peabody Mills.....	Newburyport, Mass.....	16
Pell City Mfg. Co.....	Pell City, Ala.....	720
Pelzer Mfg. Co.....	Pelzer, S. C.....	2682
Pemberton Company.....	Lawrence, Mass.....	51
Pepperell Mfg. Co.....	Biddeford, Maine.....	2814
Philadelphia Textile School.....	Philadelphia, Pa.....	2
Pickens Mills	Pickens, S. C.	432
Piedmont Mfg. Co.....	Piedmont, S. C.....	1532
Pocasset Mfg. Co.....	Fall River, Mass.....	222
Poe Mfg. Co., F. W.....	Greenville, S. C.....	764
Portland Silk Co.....	Middletown, Conn.....	1
Potomska Mills Corp.....	New Bedford, Mass.....	2
Putnam Mfg. Co.....	Putnam, Conn.....	252
Queen City Cotton Co.....	Burlington, Vt.....	1370
Quidnick Mfg. Co.....	Quidnick, R. I.....	17
Quinebaug Company.....	Danielson, Conn.....	206
Reedy River Mfg. Co.....	Greenville, S. C.....	153

NAME.	PLACE.	QUANTITY.
Revolution Cotton Mills.....	Greensboro, N. C.....	820
Rhode Island School of Design	Providence, R. I.....	1
Riverside Cotton Mills.....	Danville, Va.....	101
Roanoke Mills Company.....	Roanoke Rapids, N. C.....	260
Rosemary Mfg. Co.....	Roanoke Rapids, N. C.....	417
Royal Bag & Yarn Mfg. Co.....	Charleston, S. C.....	94
Royal Cotton Mills.....	Wake Forest, N. C.....	186
Salisbury Cotton Mills.....	Salisbury, N. C.....	210
Salmon Falls Mfg. Co.....	Salmon Falls, N. H.....	1
Salt's Textile Mfg. Co.....	Bridgeport, Conn.....	18
Samoset Company.....	Valley Falls, R. I.....	80
Saxon Mills.....	Spartanburg, S. C.....	445
Scottdale Mills.....	Atlanta, Ga.....	350
Shetucket Company.....	Norwich, Conn.....	70
Slater Cotton Co.....	Pawtucket, R. I.....	16
Slater & Sons, S.....	Webster, Mass.....	251
Spalding Cotton Mills.....	Griffin, Ga.....	2
Spartan Mills.....	Spartanburg, S. C.....	2590
Steele's Mills.....	Rockingham, N. C.....	600
Stevens Mfg. Co.....	Fall River, Mass.....	1
Stirling Silk Mfg. Co.....	Stirling, N. J.....	2
Stonewall Cotton Mills.....	Stonewall, Miss.....	1
Strickland Cotton Mills.....	Valdosta, Ga.....	20
Susquehanna Silk Mills.....	Sunbury, Pa.....	2
Swift Mfg. Co.....	Columbus, Ga.....	1
Tarboro Cotton Factory.....	Tarboro, N. C.....	200
Texas Textile School.....	College Station, Texas	2
Thistle Mill Co.....	Ilchester, Md.....	4
Thomaston Cotton Mills.....	Thomaston, Ga.....	100
Thompson & Co., Jas.....	Valley Falls, N. Y.....	12

NAME.	PLACE.	QUANTITY.
Thorndike Company.....	Thorndike, Mass.....	262
Totokett Mills Co.	Norwich, Conn.	218
Toxaway Mills.....	Anderson, S. C.....	484
Tremont & Suffolk Mills.....	Lowell, Mass.....	1976
Trion Mfg. Co.....	Trion Factory, Ga.....	951
Tucapau Mills.....	Tucapau, S. C.....	1669
United States Bunting Co.....	Lowell, Mass.....	2
United States Cotton Co.....	Central Falls, R. I.....	1600
Uncasville Mfg. Co.	Versailles, Conn.	20
Utica Cotton Co.....	Capron, N. Y.....	1
Utica Steam & Mohawk Valley Cotton Mills.....	Utica, N. Y.....	282
Vermont Mills.....	Bessemer City, N. C.....	96
Victor Mfg. Co.....	Greers, S. C.....	1428
Victory Mfg. Co.	Fayetteville, N. C.	400
Wachusett Mills.....	Worcester, Mass.....	1
Walhalla Cotton Mills.....	Walhalla, S. C.....	120
Wamsutta Mills.....	New Bedford, Mass.....	200
Ware Shoals Mfg. Co.	Ware Shoals, S. C.	1400
Warren Cotton Mills.....	West Warren, Mass.....	65
Warren Mfg. Co.....	Warrenville, S. C.....	1000
Waterhead Mills	Lowell, Mass.	6
White & Sons, N. D.....	Winchendon Springs, Mass.....	21
White & Sons, N. D.....	East Jaffrey, N. H.....	1
Whitman Mills.....	New Bedford, Mass.....	842
Whitney Mfg. Co.....	Whitney, S. C.....	652
Whittenton Mfg. Co.....	Taunton, Mass.....	1
Williamson, Jas. N. & W. H.	Raleigh, N. C.....	150

NAME.	PLACE.	QUANTITY.
Williamstown Mfg. Co.	Williamstown,	
	Mass.	2
Wilmington Cotton Mills.....	Wilmington, N. C.....	60
Woodruff Cotton Mills.....	Woodruff, S. C.....	810
Woodside Cotton Mills	Greenville, S. C.	200
York Mfg. Co.....	Saco, Maine.....	1375
		<hr/>
		133,124

**ORDERS RECEIVED BEFORE JULY 1,
BUT NOT ENTERED ON OUR SHOP
RECORDS.**

Fulton Bag & Cotton Mills.....	Atlanta, Ga.....	27
Aragon Cotton Mills	Rock Hill, S. C.	280
Columbus Public School	Columbus, Ga.	1
Laurens Cotton Mills.....	Laurens, S. C.....	660
Excelsior Mills	Farnumsville,	
	Mass.	100
Indian Head Mills of Ala.....	Cordova, Ala.....	284
Richard Borden Mfg. Co.....	Fall River, Mass.....	142
Kincaid Mfg. Co.	Griffin, Ga.	100
Dan River Cotton Mills	Danville, Va.	112
Joseph Bancroft & Sons		
Co.	Wilmington, Del.	15
Avondale Mills	Birmingham, Ala.	598
Patterson Mfg. Co.	Kannapolis, N. C.	400
Mass. Cotton Mills.....	Lowell, Mass.....	400

NAME.	PLACE.	QUANTITY.
Rosemary Mfg. Co.....	Roanoke Rapids, N.C.	220
Pacific Mills.....	Lawrence, Mass.....	1
Kansas City Cotton Mills	Kansas City, Mo.	76
Atlantic Cotton Mills.....	Lawrence, Mass.....	114
Columbia Cotton Mills	Columbia, Tenn.	102
Pelzer Mfg. Co.....	Pelzer, S. C.....	194
Mollohon Mfg. Co.....	Newberry, S. C.....	64
Lonsdale Co.....	Lonsdale, R. I.....	18
J. E. Smith Cotton Co.	Thompson, Ga.	28
Keasbey & Mattison.....	Ambler, Pa.....	4
Stonewall Cotton Mills	Stonewall, Miss.	32
Louise Mills.....	Charlotte, N. C.....	2

 3,974

**LIST OF ATTACHMENTS APPLIED TO
OTHER MAKES OF LOOMS TO
JULY 1, 1907.**

NAME.	PLACE.	Filling Changer.	Warp Stop- Motion.
Aiken Mfg. Co.....	Bath, S. C.....	1	1
Amoskeag Mfg. Co.....	Manchester, N. H.....		14,175
Androscoggin Mills.....	Lewiston, Me.....	68	68
Appleton Co.....	Lowell, Mass.....		47
Arlington Mills.....	Lawrence, Mass.....	1	19
Atlantic Cotton Mills.....	Lawrence, Mass.....	9	2
Atlantic Mills.....	Providence, R. I.....		1

NAME.	PLACE.	Filling Changer.	Warp Stop- Motion.
Bates Mfg. Co.....	Lewiston, Me.....		26
Boston Mfg. Co.....	Waltham, Mass.....		300
Botany Worsted Mills.....	Passaic, N. J.....		52
Cawthon Cotton Mills Co.	Selma, Ala.....	16	16
Chatham Mfg. Co.	Elkin, N. C.	38	
China Mfg. Co.....	Suncook, N. H.....	14	14
Continental Mills.....	Lewiston, Maine.....	1	1
Consolidated Duck Co....	Baltimore, Md.		1
Columbia Mills	Lewiston, Me.	18	
Dallas Mfg. Co.....	Huntsville, Ala.....	2	2
Davol Mills.....	Fall River, Mass.....	82	82
Eagle & Phenix Mills.....	Columbus, Ga.....		101
Earncliffe Worsted Mills	Providence, R. I.	1	
Everett Mills.....	Lawrence, Mass.....		773
Exposition Cotton Mills	Atlanta, Ga.....	1	1
Fulton Bag & Cotton Mills	Atlanta, Ga.....	502	502
German American Co.	Spray, N. C.	300	
Gibson Mfg. Co.....	Concord, N. C.....	100	
Gosnold Mills Corp.....	New Bedford, Mass....		812
Granite Linen Co.	Wortendyke, N. J.	2	
Grinnell Mfg. Corp.....	New Bedford, Mass....		2
Hargraves Mills.....	Fall River, Mass.....	45	21
Hathaway Mfg. Co.....	New Bedford, Mass....		432
King Philip Mills.....	Fall River, Mass.....	142	6

NAME.	PLACE.	Filling Changer.	Warp Stop- Motion.
Lancaster Mills.....	Clinton, Mass.....		2287
Lockwood Co.....	Waterville, Maine.....	22	28
Lorraine Mfg. Co.....	Pawtucket, R. I.....		2
Lowell Textile Co.	Lowell, Mass.	1	
Manville Co.....	Manville, R. I.....		556
Manville Co., Globe Mill	Woonsocket, R. I.....		43
Manville Co., Social Mill	Woonsocket, R. I.....		409
Mass. Mills in Georgia.....	Lindale, Georgia.....	6	6
Mechanics Mills.....	Fall River, Mass.....		1
Merrimack Mfg. Co.....	Lowell, Mass.....	98	98
Methuen Co.....	Methuen, Mass.....	1	1
Mayflower Worsted Mills	North Adams, Mass.	24	
Nashua Mfg. Co.....	Nashua, N. H.....	2	
Naumkeag Steam Cotton Co.....	Salem, Mass.....	1	1
New York Mills.....	New York Mills, N. Y.		1
Otis Company.....	Ware, Mass.....		6
Pacific Mills.....	Lawrence, Mass.....		4
Parker Mills.....	Warren, R. I.....	1	
Parkhill Mfg. Co.....	Fitchburg, Mass.....		28
Pemberton Co.....	Lawrence, Mass.....		60
Poe Mfg. Co., F. W.....	Greenville, S. C.....	13	13
Rhode Island Co.....	Spray, N. C.....	63	
Riverside Cotton Mills	Danville, Va.	1	1
Roanoke Mills Co.	Roanoke Rapids, N. C.	4	

NAME.	PLACE.	Filling Changer.	Warp Stop- Motion.
Salt's Textile Mfg. Co.	Bridgeport, Conn.	8	
Shetucket Company	Norwich, Conn.		1
Stevens Mfg. Co.	Fall River, Mass.	111	
Susquehanna Silk Mills	Sunbury, Pa.	7	
Samoset Co.	Valley Falls, R. I.	1	1
Tecumseh Mills	Fall River, Mass.	1	1
Thistle Mills	Ilchester, Md.	8	
Wm. Tinkham Co.	Harrisville, R. I.	1	
Trainer & Sons Mfg. Co., D.	Trainer, Pa.		1
Tremont & Suffolk Mills	Lowell, Mass.	8	304
Tremont Worsted Co.	Methuen, Mass.	1	
Utica Steam & Mohawk Valley Cotton Mills	Utica, N. Y.	1	1
Wassokeag Woolen Co.	Dexter, Maine.	1	
Webster Mfg. Co.	Suncook, N. H.	1	1
West Boylston Mfg. Co.	Easthampton, Mass.		2
Whittenton Mfg. Co.	Taunton, Mass.	4	16
York Mfg. Co.	Saco, Maine	1	69
		1,734 21,399	

ALSO

Complete looms, not on list, shipped to foreign countries or agents, etc.	1,987
Extra Filling-Changers	117
Extra Warp Stop-Motions	4

TOTALS.

Complete Northrop Looms sold to date,	139,085
Number of Filling-Changers applied,	1,851
Number of Warp Stop-Motions applied,	21,403
Plain Looms made at or ordered from Hopedale Works,	2,500

The looms changed over include looms made by our licensees in the United States and furnished to mills also in the United States.

These figures do **not** include the many thousand looms made under license in Canada, England, France, Germany, Switzerland, Austria and Hungary.

A few of the figures differ from former statements, inasmuch as cancellations and exchanges occur more or less. This list is correct at the time of compilation.

LOOM SALES BY STATES

Including looms only sold or equipped with complete filling changer, with comparison of sales published in 1905 :

	Number Mills in 1907	Sales to July 1st 1907	Sales to July 1st 1905
NORTHERN STATES.			
Massachusetts	59	20,840	16,875
Maine	11	7,839	5,000
Rhode Island	18	7,517	5,592
New Hampshire	15	6,389	5,155
Connecticut	12	4,550	4,508
Vermont	1	1,370	1,392
New Jersey	6	792	719

	Number Mills in 1907	Sales to July 1st 1907	Sales to July 1st 1905
NORTHERN STATES.			
New York	5	467	100
Illinois	1	96	96
Pennsylvania	4	26	65
Delaware	1	15	
Indiana	1	2	2
	<hr/>	<hr/>	<hr/>
	134	49,903	39,504
SOUTHERN STATES.			
South Carolina	63	48,344	37,064
North Carolina	39	14,247	11,244
Georgia	27	14,141	12,392
Alabama	9	6,156	3,930
Tennessee	3	2,332	2,242
Louisiana	1	714	714
Virginia	3	518	2
Maryland	3	93	8
Mississippi	4	232	199
Missouri	2	416	78
Texas	1	2	2
	<hr/>	<hr/>	<hr/>
	155	87,195	67,875
Total,	289	137,098	107,379

Where sales for 1905 are larger than in 1907 it signifies orders cancelled or delayed, or possible change in present ownership of looms sold. An increase in two years of 29,719 looms is significant—and to us quite satisfactory.

The Northrop loom has won recognition outside of the United States in spite of the difficulties of foreign introduction. The British Northrop Loom Company Limited has been established to handle a certain division of Foreign trade. The Societe Alsacienne de Constructions Mechaniques, of Mulhouse, Germany, and Belfort, France, build continuously at both of their establishments. The Ateliers de Construction Ruti, of Ruti, Switzerland, are manufacturing on various foreign orders for Switzerland, Italy, etc., and the Osterreichische Textilwerke A. G. of Vienna manufacture for Austria and Hungary.

We have sent looms from our own works to Canada, England, Mexico, Holland, Russia, Japan and elsewhere.

"The United States Investor for Nov. 3, 1906, printed lists of Cotton Mill stocks which were selling above par. In the Northern Mill list there were thirty-nine quoted. Five of these were not weaving mills. Fifteen of the thirty-four averaged 1000 Northrop looms each.

"In the Southern list there were forty mills, four of which were not weaving mills. There were thirty having Northrop looms and these thirty averaged over 1100 Northrop looms each.

"If these facts do not prove that our looms either help mills to profit or are appreciated by those who make profits we are strangely lacking in logic."—[*Cotton Chats*, Dec., '06.

"Law's Reference Book of Southern Cotton Mill Stocks," issued June 19th, 1907, gives a list of mills selected as representing those in whose stocks investors are mostly interested. It is quite evident that such a list naturally represents the salable, rather than the unsalable Southern mill stocks. The information pertaining to the mills is not always absolutely correct, as the author could not know of the latest installation of machinery. With such changes as we may make from our own knowledge of the situation, we find that there are 86 mills quoted in all. 35 of these are completely equipped with Northrop looms, 23 are partly equipped; in fact, they would average over half their equipment in Northrop looms—and 6 of them are yarn mills, leaving but 22 weaving mills which have no Northrop looms at all. This is a very significant showing, in view of the fact that in spite of our success in the South, a majority of the mills there do not use Northrop looms. The

selected list, therefore, shows 80 weaving mills, particularly chosen because of their interest to investors, of which 72½ per cent. are either wholly, or partially equipped with our loom. The little book gives, in several instances, the dividends paid for the last four years. Taking the mills partially, or wholly equipped with Northrop looms, we find that 18 of them have paid not less than 6 per cent. **for any one** of the four years, 13 of them have paid not less than 8 per cent. **for any one** of the four years, and 6 of them have paid not less than 10 per cent. **for any one** of the four years. Many of these mills have also built large additions out of their surplus, and others have a large surplus with which to pay extra dividends, or build additions.

These facts conclusively prove that the Southern Northrop loom mills average greater success than those without Northrop looms. It proves that Northrop loom mills **can**, and **do**, pay handsome dividends. We believe that had this book wider information concerning the stocks in question, we could amplify these figures, and reflect still more credit on Northrop loom equipment.—[*Cotton Chats, July, '07.*

Mills with the Northrop loom can and do show profits at the average rate of prices over long periods. One of our earliest customers, a print cloth mill, started with 320 Northrop looms. It has since increased to a total of 1759, and \$200 per share is now bid for its stock, **with none offered for sale.** It has paid continuous and satisfactory dividends while building additions out of its profits. It has reduced its capitalization so that it now stands at about \$2.50 per spindle when quick assets are considered. If any other print mill not using our looms can show an equal record for the same period we should certainly be glad to know of it.—[*Cotton Chats, Sept., '07.*

When we first marketed the Northrop loom the price per cut for weaving print cloth on common looms was 16 cents in Northern mills and 12 cents in the South. Even on this basis the first purchasers found them sufficiently profitable to soon place large repeat orders. If we were correct in assuming a saving of half the cost it was possible to make a profit of some 8 cents a cut, not counting deductions for depreciation, etc. On the same basis it is now possible to make a profit of nearly 12 cents per cut, a 50 per cent. increase. Of course we recognize that at the present prices mills with common looms can make very satisfactory profits. We have to go back to 1880 to find print cloth selling as high as now, and it is possible that the yearly average will be higher than any known since 1875. The mills must remember, however, that in the natural course of events such prices will not continue nor such profits be permanent. **The earnings at the present prices should be devoted, in part, to equipping the mills to make a profit when prices change.**—[*Cotton Chats, Sept., '07.*

In Cotton Chats for February, 1904, the writer made a comparison of Southern cotton mill stock quotations, which is reprinted in this book on pages 53-54, showing 28 mills without Northrop looms averaging a value of \$102 a share, taking the price asked, where possible, the price bid being added in only where there was no asking price. The 37 mills having Northrop looms, averaged on the same basis, \$114 per share.

Making a similar calculation from a stock list issued late in August of this year, it was found that 55 Northrop loom mills averaged over \$126 a share, 32 common loom mills averaging but \$98 a share. No mill was considered a Northrop loom mill unless it had 200 Northrop looms or more, while 7 of the 32 common loom mills had smaller numbers of Northrop looms for mere trial purposes. As the same names appear quite uniformly on these quoted lists, it is apparently evident that the common loom mills have averaged a loss in value in the last three years and a half, while the Northrop loom mills have gained surprisingly. Only 2 of the common loom mills had a price of \$150 bid or asked, and only 2 more \$125 bid or asked; whereas, the Northrop loom mills showed 2 mills with price bid or asked of \$200 or more, 8 more mills with price of \$150, or more, bid or asked, and 18 more mills with price of \$125, or more, bid or asked.

These statistics are matter of record. We did not write the figures, or influence them in any way. Anyone can make a similar reckoning; taking pains of course, to eliminate the yarn mills; also Gingham mills, and Duck mills, since the Northrop loom does not enter into their equipment, appreciably as yet. Some of the higher priced common loom mills are already considering purchase of Northrop looms in large quantity.

It is interesting to note that the very highest priced stocks are almost uniformly those of mills having larger numbers of Northrop loom equipment. Take notice also, that there are

some 55 Northrop loom mills having stock quotations, against 32 common loom mills thus quoted, although the number of common loom mills in the South is considerably larger than that of Northrop loom mills. This shows that the purchasers of stocks are more eager to buy Northrop loom mill stocks; and it also shows, by inference, that were the stocks of the absent mills quoted at fair value, we would find the difference in average price of the two classes to be even greater than that now noted.

This volume is intended to contain all the general information necessary regarding our looms, including all the information previously published in other catalogues or circulars that is pertinent. We are sometimes asked by overseers or second-hands, to send them books containing numbers and description of our various loom parts in detail. We have such printed lists and are glad to furnish them to the mills which purchase our looms, but they are too expensive in character to be generally distributed. Any overseer, or other operative can probably have access to this list in the mill office, if necessary.

As soon as this present second edition is exhausted, we shall probably follow with another in which any newer devices will be exploited. Any further information regarding looms, or any of our other products, will be cheerfully furnished on application.

DRAPER COMPANY,

November 1, 1907.

HOPEDALE, MASS.

TABLE OF CONTENTS.

Miscellaneous—Frontispiece, title, preface, etc.....	1-5
Our Location	6-7
Draper Exhibit at Philadelphia	8
Concerning Draper Company.....	9
Former literature on the Northrop Loom.....	10-16
Spinners and Weavers of America	17-23
The Art of Weaving.....	24-31
History of the Northrop Loom.....	32-39
The Northrop Innovations.....	40-48
Prices and Profits	49-59
Attempts at Competition.....	60-64
Loom Models.....	65-73
Hoppers	73-75
Double Fork and Feeler Combinations.....	76-78
Bobbins.....	79-80
Shuttles	81
Cop Skewers	82
Thread Cutting Temples.....	83
Lacey Top Rig	84
Warp Stop-Motions	85-88
Cut Motion	88-89
Let-off Motions	90-92
Common Loom	93
Loom Construction.....	94
Milling Loom Frames	95-96
Bolton Loom Seat.....	97
Keene Drawing-in Frame.....	98
Sullivan Shuttle Guard.....	99
Durkin Thin Place Preventer	100

Specification	101-107
Southern Supply Office	108
Method of Filling Hoppers	109-110
Arrangement of Looms	110-111
Weavers' Seat	112
Instructions for Running Northrop Looms	113-172
Convenient Multipliers	172-174
Statistics	174-184
Quotations	185-187
Photographs of Cloth	188-189
The Labor Question	190-193
Quotation	194
Sales	195-213
Stock Quotations	213-216
Table of Contents	217-218
Index	219-222
Memoranda	223-224

INDEX.

Art of Weaving.....	24-31
Bobbins.....	39, 60, 64, 79-80, 102-103, 122-124, 141
Brake.....	72, 157-158
Breakage of Filling.....	121-122
Bunches in Cloth.....	124-125
Bunches on Feeler Bobbins.....	104, 143-144
Census Reports.....	174-183
Center Forks.....	58
Changing over Looms.....	28, 93
Child Labor.....	57
Cloth Defects.....	58, 165-168
Cloth Inspection.....	58
Common Looms.....	28, 31, 42-43, 93
Cloth, samples of.....	188-189
Competition.....	37, 60-64
Cop Looms.....	59, 64, 82, 122, 125-126
Cop Skewers.....	82, 102-103, 125-126
Cost of Weaving.....	14-15, 27, 47, 53, 185, 187
Cotton Mill Products.....	175, 180-181
Cut Motion.....	40, 68, 88-89, 103
Depreciation.....	54-56
Dobby.....	58-59, 65, 70
Double Fork.....	68, 76-78, 104, 150-151
Double Pick Cloth.....	165
Draper Company.....	2, 6-7, 9, 27
Drawing-in Frame.....	98, 159
Drop Wires.....	42, 85-88, 131-135, 168
Feeler, (or Mispick Preventer).....	37, 42, 59, 68, 76-78, 115-116, 125, 140-146, 167

Feeler Thread-Cutter	76-77, 115-116, 144-146
Filling Fork	31, 76-78, 113, 120, 150-151
Floats (overshots)	43-44, 165-166
Foreign Loom introduction	36-39, 113, 213
Hand Loom	21, 24-26, 29-30, 44
Harness Cams	137
Heddles	42, 85-86, 104-105, 126-131
History	17-39
Hopper	38, 40-43, 52, 73-75, 109-110, 113-116
Humidity tables	169
Instructions for Running Northrop Looms	113-172
Inventions	9, 25, 27-31, 33-35, 37-38
Jacquards	58-59
Knots in Warp	136
Labor Question	39, 190-193
Labor on Plain Loom	31, 42-44, 46
Labor on Northrop Looms	15, 43, 46-48
Lay	151-152
Let-off	32, 90-92, 103, 146-147, 166-167
Literature on Northrop Loom	10-16
Litigation	33, 38, 63-64
Location of Works	7
Long Bobbin Experiments	60, 64
Loom Adjustments	158-159
Loom Arrangement	110-111
Loom Cleaning	161-162
Loom Construction	94-96
Loom Cost	54, 57, 164
Loom Dimensions	101
Loom Earnings	47, 55, 190
Loom Equipment	164-165
Loom Licenses	36-37, 39, 213
Loom Models	32, 50, 65-73

Loom Power	161
Loom Seats	68, 97, 106
Loom Specifications	102-107
Loom Repairs	109, 162
Loom Speed	31, 163-164, 170
Loom Tests	36, 168-169
Loom Prices	49-56
Loom Profits	62
Loom Supplies	108, 164-165
Loom Temples	27, 31, 83, 106, 118, 138-140
Misthread Stop-motions	120
Misthreading	119-121, 142
Multipliers	172-174
Northrop Loom Products	58-59, 187-189
Number of Looms per Weaver	15-16, 46-48
Patents	38, 51, 60-64, 194
Patent Infringement	38, 60-64
Patent Investigation	35-37
Percentage of Production	46-48, 58, 163
Philadelphia Exhibit	8, 16
Plan of Works	6
Prices Paid for Weaving	15, 46-47, 51, 92
Product per Operative	30-31, 44, 46-48, 162-163
Profits by use of Northrop Loom	14, 49-56
Protector	118, 156
Reed	106-107, 118, 153-154
Repairs	162, 186-187
Replacement of Common Looms	45
Rules for Weavers	170-172
Sales of Northrop Looms	36, 45, 48, 195-213
Seconds	58-59
Selvage	138
Shedding Motion	66, 68, 71, 84-85, 105, 137, 158

Shortage of Help	57
Shuttles	40, 81, 107, 117-122, 142-143
Shuttle Boxes (including binders)	119, 154-156
Shuttle Changers	16, 30, 33-35, 37-38, 60-61, 64
Shuttle Guard	99
Shuttle Position Detector (or shuttle feeler)	114-116, 120, 143
Sizing Warp	159-160
Slack threads	134-135
Specifications	102-107
Spinners and Weavers of America	17-23
Statistics	174-184
Stock Valuation	53-54, 213-216
Take-up	32, 50, 84, 89, 101, 103, 107, 147-151
Temple Thread-cutter	83, 138-140
Thin-place Preventer	100, 104
Warp Beams	147
Warp Breakage	118, 135-136
Warp Sizing	159-160
Warp Stop-motion	32, 38-40, 42-44, 60-61, 66, 85-88, 104-105, 126-135
Weavers' Seat	112
Weavers' Earnings	15, 46-47, 92, 109, 185, 187, 190-194

MEMORANDA.

MEMORANDA.

CARNEGIE LIBRARY OF PITTSBURGH



3 1812 04052 5710